



At the heart of your home

Windsor & Stirling Plus

INSET LIVE FUEL-EFFECT GAS FIRES

Installation, Maintenance & User Instructions.

Hand these instructions to the user after installation.

Model No's FSPCMN, FSPP**MN & FSPC**SN are for use on Natural Gas (G20) at a supply pressure of 20 mbar in G.B. / I.E.**

**** denotes variant of trim / fascia where applicable**

Information Requirements for Commission Regulation (EU) 2015/1188

Model Identifier	FSPC**MN, FSPP**MN & FSPC**SN
Indirect Heating Functionality	No
Direct Heat Output	4.0kW (Manual Control) 3.8kW (Slide Control)
Indirect Heat Output	Not Applicable
Fuel	Natural Gas (G20)
NOx Emissions	130mg/kWh
Nominal Heat Output	4.0kW (Manual Control) 3.8kW (Slide Control)
Minimum Heat Output (Indicative)	1.1kW
Useful Efficiency at Nominal Heat Output	66.8%
Useful Efficiency at Minimum Heat Output (Indicative)	50.0%
Auxilliary power consumption at nominal heat output - manual & slide control models	Not applicable
Auxilliary power consumption at minimum output - manual & slide control models	Not applicable
Auxilliary power consumption at standby mode - manual & slide control models	Not applicable
Permanent pilot flame requirement	Not applicable
Type of heat output / room temperature	Two or more manual control stages, no room temperature control
Contact Details	BFM Europe Ltd. Gordon Banks Drive Trentham Lakes North Stoke-on-Trent ST4 4TJ Tel : 01782 339000

CONTENTS PAGE

Section 1	Information and Requirements	PAGE
1.0	Appliance Information	3-4
1.1	Conditions of Installation	5
1.2	Flue and chimney suitability	5
1.3	Fireplace / surround suitability	6
1.4	Shelf position	6
1.5	Chimney inspection	6-7
1.6	Fire place opening / catchment space	7-8
1.7	Fitting to metal flue boxes	8
1.8	Hearths - standard models	9
1.9	Pre-cast flue installations	9
1.10	Spillage monitoring system	9
1.11	Wall mounting - contemporary wall hung models	10
Section 2	Installation of Fire	
2.1	Unpacking the fire	11
2.2	Installing the fire box	11-15
2.3	Gas tightness and inlet pressure (manual control models)	16
2.4	Gas tightness and inlet pressure (slide control models)	16
Section 3	Assembling Fuel Bed and Commissioning	
3.1	Assembling the ceramics and fuel bed (coal variants)	17-19
3.2	Assembling the ceramics and fuel bed (pebble variants)	20-21
3.3	Lighting the fire (manual control models)	22
3.4	Lighting the fire (slide control models)	22
3.5	Fitting the trim	23
3.6	Fitting the fender	23
3.7	Fitting the contemporary and four sided fascia's	24
3.8	Checking for clearance of combustion products	25-26
Section 4	Maintenance	
4.1	Removal of the burner assembly (manual control models)	27
4.2	Removal of the piezo igniter (manual control models)	27
4.3	Removal of the control tap (manual control models)	28
4.4	Removal of the pilot assembly (manual control models)	28
4.5	Removal of the burner assembly (slide control models)	29
4.6	Removal of the battery igniter (slide control models)	29
4.7	Replacing the battery (slide control models)	30
4.8	Removing the oxy-pilot assembly (slide control models)	30
4.9	Replacing the control cable (slide control models)	30-31
	Part Shortlist / Fret Information	32
Section 5	User Instruction Section	
5.1	Conditions of Installation & about your new fire	33-34
5.2	Operating the fire (manual control models)	35
5.3	Operating the fire (slide control models)	36
5.4	Replacing the battery in slide control models	36
5.5	Spillage monitoring system	37
5.6	Cleaning instructions	37
5.7	Re-assembling the ceramics and fuel bed (coal models)	38-39
5.8	Re-assembling the ceramics and fuel bed (pebble models)	40-41
	User replaceable parts	42

SECTION 1 INFORMATION AND REQUIREMENTS

1.0 APPLIANCE INFORMATION

Model	FSPC**MN (MC) FSPP**MN (MC)	FSPC**SN (SC)
Gas Type	G20	G20
Main injectors (1 off)	Size 440 (MC)	Size 380 (SC)
Burner Type / Pilot Type	Aeromatic self vitiating tubular burner	SIT YA OP 9055 (SC)
Maximum gross heat Input :	6.5 kW	6.3 kW
Minimum gross heat Input :	2.2 kW	2.2 kW
Cold Pressure :	20.0 +/-1.0 mbar (all models)	
Ignition :	Push button piezo (manual control models) 1.5V battery generator (slide control models)	
Electrode Spark Gap	4.5mm	4.0mm
Weight	14.0kg	19.0kg

This appliance is manufactured by:-

BFM Europe Ltd,
Trentham Lakes,
Stoke-on-Trent,
ST4 4TJ.

Fire box Dimensions (Windsor Plus & Stirling Plus Models)

Width :	(with trim, no spacer)	485mm
Height :	(with trim, no spacer)	595mm
Depth :	(overall-without fender)	120mm

Fire box Dimensions (Windsor Wall Hung Contemporary Models)

Width :	(with trim, no spacer)	512mm
Height :	(with trim, no spacer)	672mm
Depth :	(overall-without fender)	120mm

Gas Connection 8mm Compression (Supplied with fire)

Appliance Efficiency Declaration

The efficiency of this appliance has been measured as specified in BS 7977-1 : 2009 + A1 : 2013 and the result is 60.7%.

The gross calorific value of the fuel has been used for this efficiency calculation.

The test data from which it has been calculated has been certified by BSI. The efficiency value may be used in the UK Government's Standard Assessment Procedure (SAP) for energy rating of dwellings.

INSTALLATION REQUIREMENTS

1.1 CONDITIONS OF INSTALLATION

It is the law that all gas appliances are installed only by a GAS SAFE Registered Installer, in accordance with these installation instructions and the Gas Safety (Installation and Use) Regulations 1998 as amended. Failure to install appliances correctly could lead to prosecution. It is in your own interest and that of safety to comply with the law.

The installation must also be in accordance with all relevant parts of the Local and National Building Regulations where appropriate, the Building Regulations (Scotland Consolidation) issued by the Scottish Development Department, and all applicable requirements of the following codes of practice :-

1. BS 5871 Part 2 Installation of Inset Live Fuel Effect Gas Fires
2. BS 6891 Installation of Gas Pipework
3. BS 5440 Parts 1 & 2 Installation of Flues and Ventilation
4. BS 1251 Open fire place components
5. BS 715 / BS EN 1856-2 Metal flue pipes for gas appliances
6. BS 6461 Part 1 Installation of Chimneys and flues
7. BS 1289 / BS EN 1858 Chimneys Components & Concrete Flue Blocks
8. IS 813 : 1996 Domestic Gas Installation (Republic of Ireland)

No purpose made additional ventilation is normally required for this appliance, when installed in G.B. When installing in I.E. please consult document I.S. 813 : 1996 Domestic Gas Installation, which is issued by the National Standards Authority of Ireland. If installing in Northern Ireland, please consult local building regulations. Any purpose made ventilation must be checked periodically to ensure that it is free from obstruction.

1.2 FLUE AND CHIMNEY SUITABILITY

This appliance is designed for use with conventional brick built or lined chimneys and fabricated flues and metal flue boxes conforming to BS 715 / BS EN 1856-2. All flues must conform to the following minimum dimensions.

Minimum diameter of circular flues	125 mm (without flue restrictor fitted)
Minimum effective height of all flue types	3 metres

When fitting to conventional chimneys or 175mm flues it may be desirable to fit the flue restrictor baffle (supplied) to reduce the flue flow and increase the efficiency of the fire. Safe clearance of products must always be checked by carrying out a smoke match test as described.

1.3 FIREPLACE / SURROUND SUITABILITY

The fire must only be installed on a hearth it **must not be installed directly onto carpet or other combustible floor materials.**

The fire is suitable for fitting to non-combustible fire place surrounds and proprietary fire place surrounds with a temperature rating of at least 150^oc. (Class "O")

If a heating appliance is fitted directly against a wall without the use of a fire surround or fire place all combustible material must be removed from behind the trim. Soft wall coverings such as blown vinyl, wall paper etc. could be affected by the rising hot air and scorching and/or discoloration may result. Due consideration should be made to this when installing or decorating.

1.4 SHELF POSITION

The fire may be fitted below a combustible shelf providing there is a minimum distance of 200mm above the top of the fire and the shelf does not project more than 150mm. If the shelf overhangs more than 150mm the distance between the fire and the shelf must be increased by 15mm for every 25mm of additional overhang over 150mm.

1.5 FLUE / CHIMNEY INSPECTION

Before commencing installation, a flue or chimney should be inspected to ensure that all the following conditions are satisfied.

1. Check that the chimney / flue only serves one fire place and is clear of any obstruction. Any dampers or register plates must be removed or locked in the open position.
2. Brick/stone built chimneys or any chimney or flue which has been used for an appliance burning fuel other than gas must be thoroughly swept. The base of the chimney / flue must also be thoroughly cleared of debris etc.
3. Any under-floor air supply to the fire place must be completely sealed off.
4. Ensure that the inside of the chimney / flue is in good condition along it's length and check that there is no leakage of smoke through the structure of the chimney during and after the smoke pellet test.
5. **Using a smoke pellet, check that there is an up-draught in the chimney / flue and that the smoke can be seen issuing from the terminal / chimney pot outside. There must be no leakage of smoke through the structure of the chimney during or after the smoke pellet test and it is important to check inside upstairs rooms adjacent to the chimney / flue.**

Check the chimney pot / terminal and general condition of the brickwork or masonry. If the chimney or flue is in poor condition or if there is no up-draught do not proceed with the installation. If there is a history of down-draught conditions with the chimney / flue, a tested and certificated flue terminal or cowl suitable for the relevant flue type should be considered.

6. **A spillage test must always be carried out during commissioning of the appliance.**

1.6 FIRE PLACE OPENING AND CHIMNEY CATCHMENT SPACE

The front opening of the fire place must be between 330 and 440mm wide, and between 550 and 575mm high. If the opening exceeds these dimensions then a surround must be constructed from suitable non-combustible material to produce a correct size opening. Any surround must be suitably sealed to the fire place to prevent leakage. See below in figure 1.

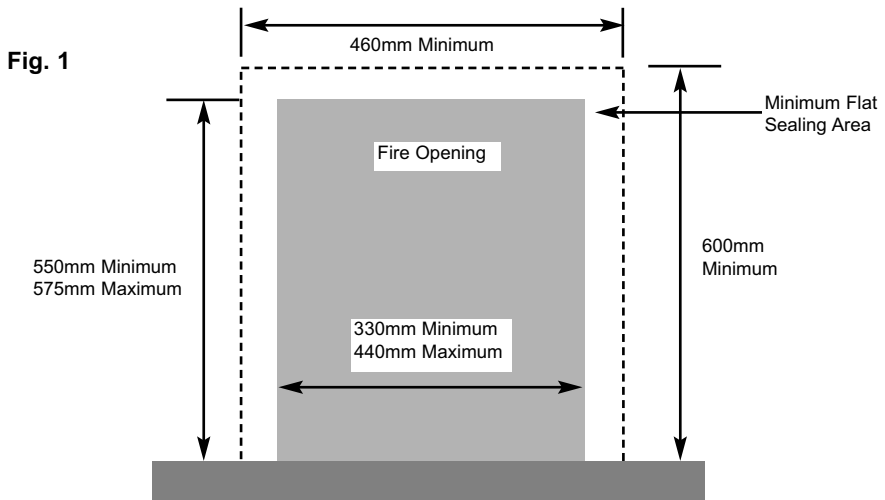

When installing into a brick built chimney, you must ensure that there is sufficient depth to accommodate any debris which may fall from the chimney. This depth must be sufficient to accommodate 12 litres of volumetric space.

Table A - Installation Depth Requirements for a Flavel Windsor Plus / Stirling Plus being installed into a brick built chimney, requiring 12.0 litres of debris collection volume (figure 2)

Opening Width (mm)	Minimum Depth Required (mm)
330 (minimum opening width)	152
340	149
350	146
360	144
370	142
380	139
390	137
400	135
410	135
420	135
430	135
440 (maximum opening width)	135

For example, if the appliance was to be fitted into a 400mm wide opening, the depth required would be 135mm. See figure 2 below for explanatory diagram.

Fig. 2

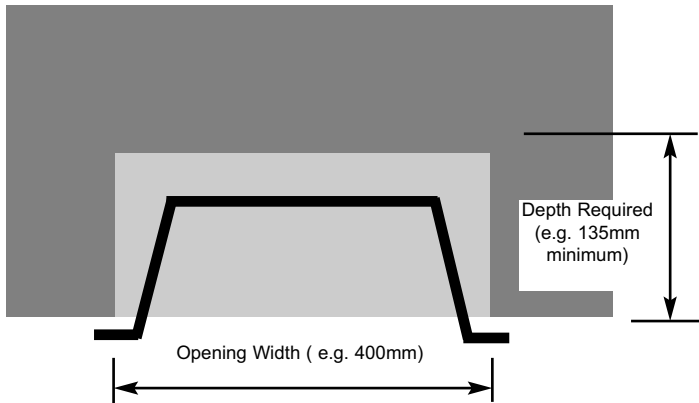

1.7 FITTING TO PRE-FABRICATED TWIN WALL METAL FLUE BOXES

The appliance may be fitted to twin wall metal flue boxes conforming to the constructional requirements of BS 715 / BS EN 1856-2, (for example the Selkirk LFE 175 box). The box must have a minimum flue diameter of 125mm internal and minimum internal dimensions of 185mm deep by 580mm high by 400mm wide. There are no maximum dimensional requirements for the box. The top face of the box must be insulated with a minimum thickness of 50mm of non-combustible mineral wool insulation or similar material. The flue box must stand on a non-combustible base of minimum thickness 12mm.

1.8 HEARTH

This appliance must only be installed on to a concrete or non-combustible hearth. The hearth material must be a minimum thickness of 13mm with the top surface at least 50mm above the floor. The hearth must be fitted symmetrically about the fire opening and have a minimum width of 760mm and a minimum projection of 300mm forwards from the fire opening.

1.9 FITTING TO PRE-CAST FLUE INSTALLATIONS

When installing this appliance into pre-cast flues, always ensure that the spigot restrictor baffle has been removed. (2 screws). To install the fire box in to pre-cast flue starter blocks, there must be at least 135mm from the mounting face of the fire to the rear of the pre-cast flue starter block. It is important to consider this depth when choosing a fire surround as the thickness of the fire surround must be sufficient to give a total depth of at least 135 mm to the rear of the starter block, otherwise there will be insufficient depth. To increase this depth the fire surround may be packed away from the wall and sealed using suitable material when used in conjunction with a rebated fire surround. It is important to ensure that the pre-cast flue is in good condition and is free from extruded mortar or sealant from between the flue blocks. This appliance has been tested for use in a pre-cast flue block system complying with BS EN 1858 / BS 1289, that has a minimum cross sectional of 13,328mm² and no minor dimension of less than 63mm. Pre-cast flues built with directly plastered faces (front or rear) are not correctly installed as to ensure proper operation with any type of inset gas fire. In some instances of this flue construction, temperature cracking of surface plaster may occur through no fault of the appliance. An air gap or some form of insulation material should be installed to prevent normal flue temperatures from damaging wall surfaces. BFM Europe will not be liable for subsequent costs incurred due to installation of products into pre-cast flue systems with directly plastered faces. It is important to ensure that the pre-cast flue is in good condition and is free from extruded mortar or sealant from between the flue blocks. A spillage test must always be carried out to check satisfactory clearance of combustion products is achieved on all pre-cast flue types.

1.10 SPILLAGE MONITORING SYSTEM

This appliance is fitted with an atmosphere sensing spillage monitoring system in the form of an oxygen sensing pilot. This is designed to shut the fire off in the event of a partial or complete blockage of the flue causing a build up of combustion products in the room in which the fire is operated. **The following are important warnings relating to this spillage monitoring system :-**

- 1) The spillage monitoring system must not be adjusted by the installer.
- 2) The spillage monitoring system must not be put out of operation.
- 3) When the spillage monitoring system is exchanged only a complete original manufacturers part may be fitted.

1.11 WALL MOUNTING - CONTEMPORARY WALL HUNG MODELS

This appliance must be fitted on a flat, non-combustible base of minimum thickness 12mm. In addition, a non-combustible hearth or physical barrier should be provided in front of the fire.

With “hole in the wall” type installations, where it may be desirable not to fit a hearth panel or physical barrier, the product may be installed in accordance with Document J of the building regulations so that every part of the flame or incandescent material is at least 225mm above the floor level. For the customers safety, and in accordance with BS 5871-2, the fitting of a hearth panel or physical barrier should be carried out. Should this advice not be followed however, please give consideration to the safety of the occupants in the room to which the appliance is installed.

Any hearth panel or physical barrier that is fitted should project a minimum of 300mm forwards from the fire opening and 150mm either side of the fire opening, as shown below in figure 3. Any physical barrier must be securely fixed and be of robust design.

Fig. 3

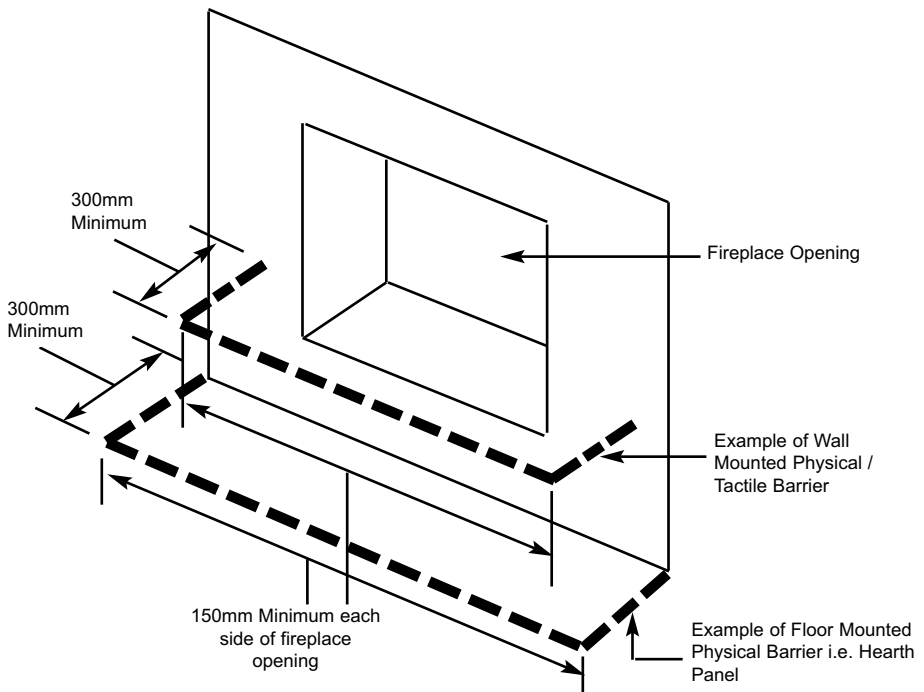

SECTION 2 INSTALLATION OF FIRE

2.1 UNPACKING THE FIRE

Carefully lift the fire out of the carton. Remove the loose item packaging carefully from the front of the appliance. Check the contents as listed :-

Packing check list - manual control models

1 off	Fire box / burner assembly
1 off	Boxed ceramic base & 7 synthetic coals
1 off	Loose items bag inc guarantee card and cable fixing kit
1 off	Installation / user book (combined)
1 off	Flue restrictor baffle
1 off	Trim & fret or fascia (dependent upon model of fire ordered)
1 off	Pebble set (if ordered as an optional extra) pack 2 of 2

Packing check list - slide control models

1 off	Fire box / burner assembly
1 off	Boxed ceramic base & 7 synthetic coals
1 off	Loose items bag inc guarantee card and cable fixing kit
1 off	Installation / user book (combined)
1 off	1.5V AA battery
1 off	Flue restrictor baffle
1 off	Trim & fret or fascia (dependent upon model of fire ordered)
1 off	Pebble set (if ordered as an optional extra) pack 2 of 2

2.2 INSTALLING THE FIRE BOX

Establish which type of flue you are intending to install the fire in to :-

225 x 225mm (9 inch x 9 inch) brick built chimneys

175mm (7 inch) diameter lined brick or stone flue, insulated pre-fabricated metal flue box to BS 715 / BS EN 1856-2 or Pre-Cast Flue to BS 1289 / BS EN 1858. When installing into 125mm (5 inch) diameter lined brick or stone flue, or insulated pre-fabricated metal flue box to B.S. 715 and pre-cast flues the restrictor baffle must not be fitted.

A spillage test must always be carried out to check satisfactory clearance of flue products, regardless of the type of flue the appliance is being fitted to.

For manual control models proceed as follows :-

2.2.1 Remove the two screws at the bottom of the control panel. See figure 4 below.

Fig. 4

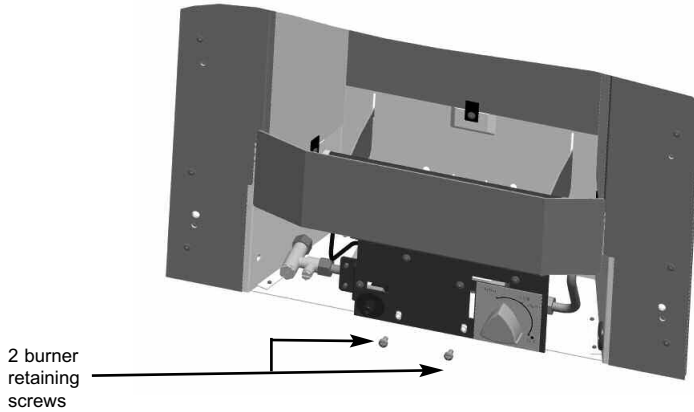

2.2.2 The base of the burner unit can now be lifted, lift the two retaining tabs on the burner brackets from the back of the firebox, allowing the burner to be removed. See figure 5 below.

Fig. 5

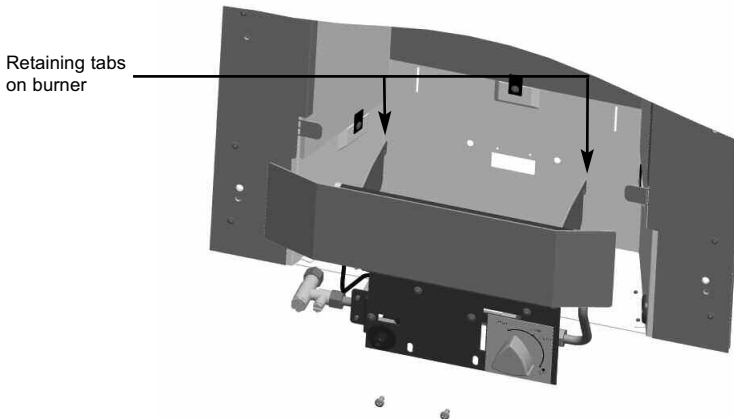

For slide control models proceed as follows :-

2.2.3 Remove the two screws at the bottom of the control panel. See figure 6 below.

Fig. 6

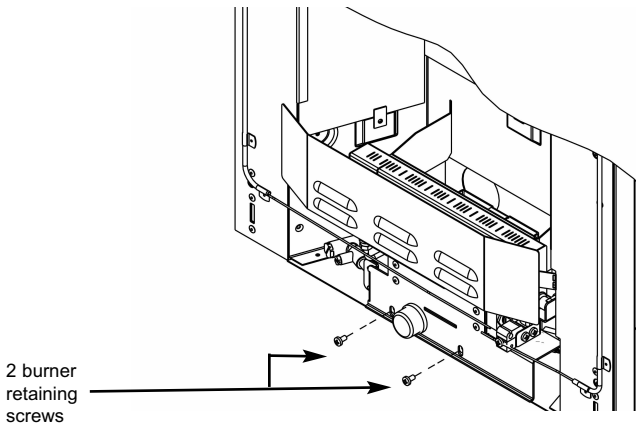

2.2.4 Remove the burner. To allow burner removal, the control lever operating cable must be removed. The control lever operating cable can be seen running across the base of the fire, below the burner. To release the cable, unscrew the cable securing screw located in the centre of the aluminium operating arm and release the front part of the operating arm, thereby freeing the cable from the burner. Note the securing screw is retained in the block to prevent it from being lost. Release the other end of the cable by pushing the cable forwards to the right, i.e. into the operating arm so as to release the tension. Pull the cable nipple out of the retaining hole and remove the cable through the slot in the operating arm. See figure 7 overpage

Fig. 7

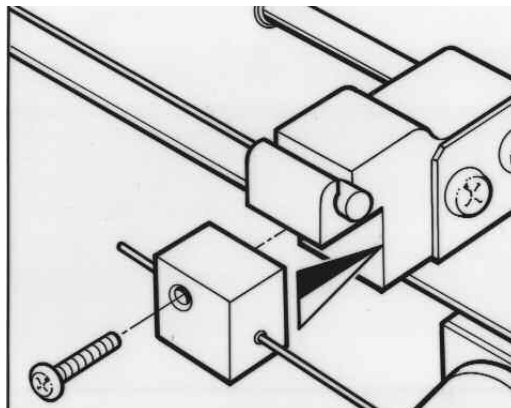

- 2.2.5 Ensure that the hearth is protected from damage and carefully lift the fire box into the fire opening, then slide it back into position. Check that the fire box flange fits flush to the sealing face of the fire surround or wall with no gaps present.

Continue for all models

- 2.2.6 Whilst the fire box is still in position, decide which side the gas supply is to enter the fire from. If concealed pipe work is required plan the pipe run to enter the fire box through one of the openings in the sides or rear of the fire box below the fuelbed support panel and connect to the isolating / inlet elbow. The gas connection to the appliance should be made to the isolating / inlet elbow using 8mm rigid tubing. There must be no soldered joints within the firebox. See figure 8 & 9 below for suggested concealed pipe layouts.

Fig. 8 - R/H/S Gas Supply Route

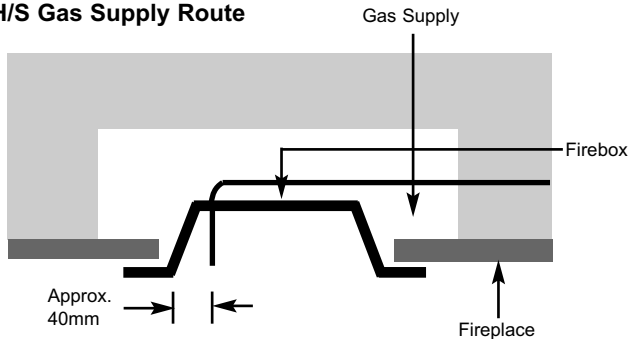
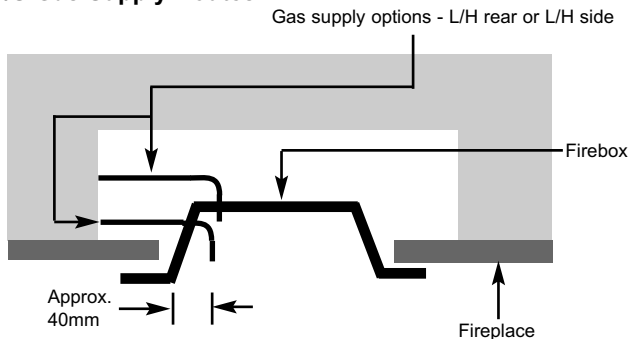

Fig. 9 - L/H/S Gas Supply Routes



Note : Before breaking into the gas supply a tightness test should be carried out to establish that the existing pipework is sound.

Carefully withdraw the fire box from the opening to enable the gas supply and fire fixing to be completed.

IMPORTANT : THE 45MM GROMMET SUPPLIED IN THE LOOSE ITEMS MUST BE USED TO SEAL THE GAS INLET POINT UTILISED ON THE FIREBOX. FAILURE TO SEAL THIS INLET POINT COULD RESULT IN FLAME REVERSAL AND DAMAGE TO THE CONTROLS ON THE FIRE. BFM EUROPE ACCEPT NO RESPONSIBILITY FOR DAMAGE TO THE FIRE AS A RESULT OF FAILURE TO FOLLOW THIS REQUIREMENT.

The preferred method of fixing which is suitable for almost all situations is the cable fixing method which is described in the following section in detail.

To fit using the **preferred** cable method proceed as follows-

- 2.2.7 Mark out and drill 4 off No 14 (6mm) holes in the back face of the fire opening in the positions shown below in figure 10.

Fig. 10

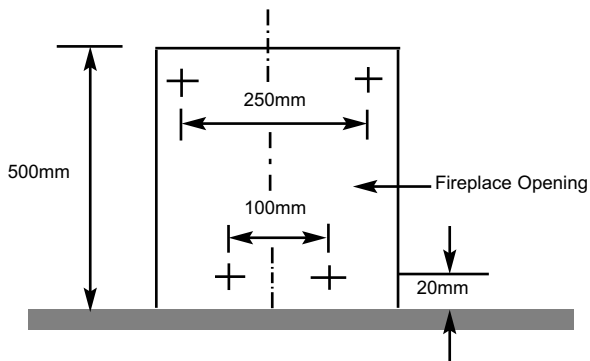

Fit the wallplugs provided and screw the fixing eyes securely into the rear of the fire opening.

- 2.2.8 Uncoil the two fire fixing cables and thread one end of each of the cables through one of the two holes on each side of the flue outlet shroud.
- 2.2.9 Position the fire carefully on the (protected) surface of the hearth and reach into the fire opening. Thread each of the cables vertically downwards through the pair of fixing eyes on the same side of the fire. Thread the free end of the cables through the corresponding circular hole on each side of the lower rear of the fire. Carefully slide the fire box back into the fire opening and pull both cables tight.
- 2.2.10 Thread a tensioning screw over each of the cables and ensure that the tensioning nut is screwed fully up against the hexagon shoulder of the tensioning screw (this provides maximum travel for the tensioning nut).
- 2.2.11 Fit a screwed nipple on to each of the cables and pull hand tight up against the tensioning screw, then secure each nipple with a flat bladed screwdriver. See figure 11 overpage.

Fig. 11

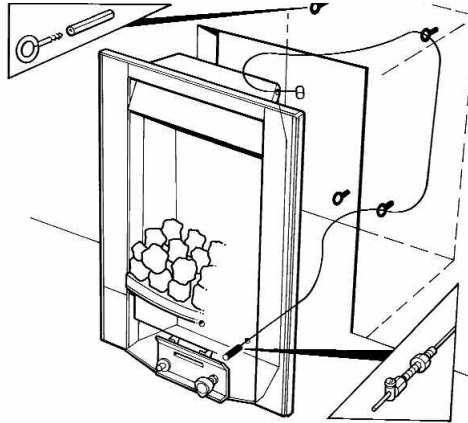

- 2.2.12 Evenly tighten the tensioning nuts to tension both cables and pull the fire snugly against the wall. Do not overtighten, it is only necessary to pull the seal up against the sealing face of the wall, it does not need to be compressed. Check that there are no gaps behind the seal.
- 2.2.13 With the fire securely in place, if a concealed gas connection has been made through either of the access holes in the sides of the fire, the holes should be closed around the pipe to prevent leakage of air through the gap around the pipe.
- 2.2.14 Refit the burner. Fit the two retaining screws and check that the burner is correctly locked into position.
- 2.2.15 **Before making the final gas connection, thoroughly purge the gas supply pipework to remove all foreign matter, otherwise serious damage may be caused to the gas control valve on the fire.**

2.3 GAS TIGHTNESS AND INLET PRESSURE (MANUAL CONTROL MODELS)

- 2.3.1 Remove the pressure test point screw from the inlet elbow and fit a manometer.
- 2.3.2 Turn on the main gas supply and carry out a gas tightness test.
- 2.3.3 Depress the control knob and turn anti-clockwise to the position marked ignition / low. Hold in the control knob for a few seconds to purge the pipe work then press the igniter button. The burner should light, continue to hold the control knob for a few seconds then turn to the full-on position.
- 2.3.4 Check that the gas pressure is **20.0 mbar (+/- 1.0mbar) 8.0 in w.g.(+/- 0.4 in w.g.)**
- 2.3.5 Turn off the fire, remove the manometer and refit the pressure test point screw. Check the pressure test point screw for gas tightness with the appliance turned on using a suitable leak detection fluid or detector.

2.4 GAS TIGHTNESS AND INLET PRESSURE - SLIDE CONTROL MODELS.

- 2.4.1 Remove the pressure test point screw from the pressure test point and fit a manometer.
- 2.4.2 Turn on the main gas supply and carry out a gas tightness test.
- 2.4.3 Depress the control lever to the position marked pilot. Hold down the control lever for a few seconds to purge the pipe work. The burner should light, continue to hold the control lever for a few seconds to latch the valve then lift to the full-on position.
- 2.4.4 Check that the gas pressure is **20.0 mbar (+/- 1.0mbar) 8.0 in w.g.(+/- 0.4 in w.g.)**
- 2.4.5 Turn off the fire, remove the manometer and refit the pressure test point screw. Check the pressure test point screw for gas tightness with the appliance turned on using a suitable leak detection fluid or detector.

SECTION 3 ASSEMBLING FUEL BED AND COMMISSIONING

3.1 ASSEMBLING THE CERAMICS AND FUEL BED - COAL MODELS

- 3.1.1 Place the fuelbed base centrally on to the fuelbed support and push fully backwards to the rear face of the fibre boards **Make sure that the fuelbed base is located centrally in the fire box, behind the retaining tabs as shown below in figure 12.**

Fig. 12

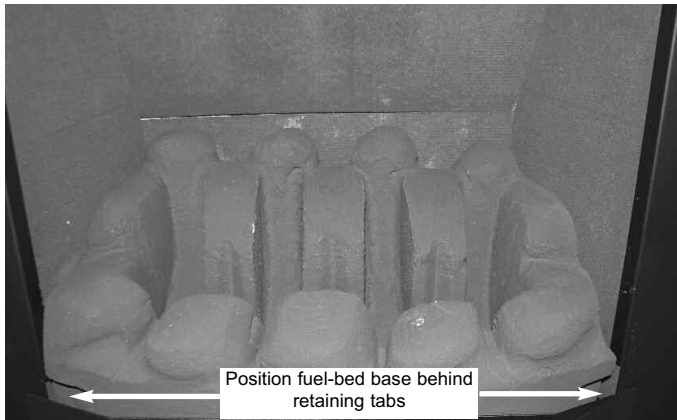

- 3.1.2 Position the front row of four large loose coals along behind the first row of coals, ensuring that the flame paths as indicated are not interrupted. See figure 13 below.

Fig. 13



- 3.1.3 Select 3 off coals and arrange along the rear of the fuelbed, using the ribs in the rear of the fuelbed as a guide for placement, see figure 14 below.

Fig. 14



The exact position and fit of the coals may be finely adjusted to give the best appearance.

Warning : Use only the coal set supplied with the fire. When replacing the coals remove the old coals and discard them. Fit a complete set of coals of the correct type. Do not fit additional coals or any coals other than a genuine replacement set.

This appliance uses fuel effect pieces containing Refractory Ceramic Fibres (R.C.F.), which are man-made vitreous silicate fibres. Excessive exposure to these materials may cause temporary irritation to eyes, skin and respiratory tract. Consequently, it makes sense to take care when handling these articles to ensure that the release of dust is kept to a minimum. To ensure that the release of fibres from these R.C.F. articles is kept to a minimum, during installation & servicing we recommend that you use a HEPA filtered vacuum to remove any dust and soot accumulated in and around the fire, before and after working on the fire. When replacing these articles we recommend that the replaced items are not broken up, but are sealed within a heavy duty polythene bag, clearly labelled as "RCF waste". This is not classified as "hazardous waste" and may be disposed of at a tipping site licensed for the disposal of industrial waste. Protective clothing is not required when handling these articles, but we do recommend you follow the normal hygiene rules of not smoking, eating or drinking in the work area, and always wash your hands before eating or drinking. This appliance does not contain any component manufactured from asbestos or asbestos related products.

3.2 ASSEMBLING THE CERAMICS AND FUEL BED - PEBBLE MODELS

- 3.2.1 Place the fuelbed base centrally on to the fuelbed support and push fully backwards to the rear face of the fibre boards **Make sure that the fuelbed base is located centrally in the fire box, behind the retaining tabs** as shown below in figure 15.

Fig. 15

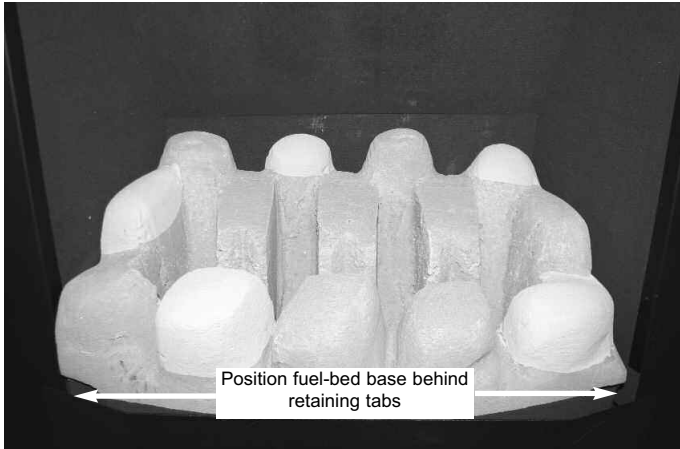

- 3.2.2 Position the front row of four large loose pebbles along behind the first row of pebbles, ensuring that the flame paths as indicated are not interrupted. See figure 16 below.

Fig. 16

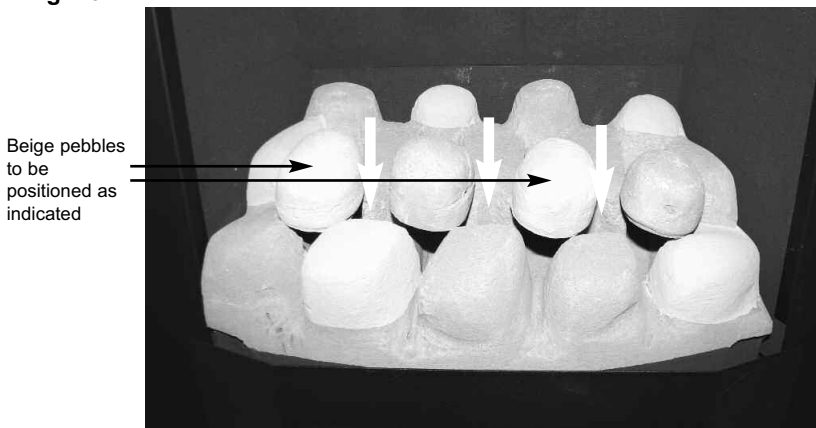

3.2.3 Fit the three small pebbles onto the ribs in the fuelbed as shown below, ensuring that the rear flame paths as indicated are not interrupted. See figure 17 below.

Fig. 17

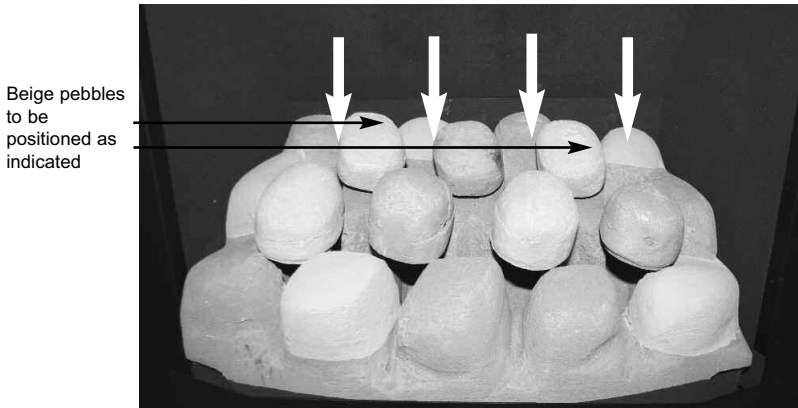

The exact position and fit of the pebbles may be finely adjusted to give the best appearance.

Warning : Use only the pebble set supplied with the fire. When replacing the pebbles remove the old pebbles and discard them. Fit a complete set of pebbles of the correct type. Do not fit additional pebbles or any pebbles other than a genuine replacement set.

This appliance uses fuel effect pieces containing Refractory Ceramic Fibres (R.C.F.), which are man-made vitreous silicate fibres. Excessive exposure to these materials may cause temporary irritation to eyes, skin and respiratory tract. Consequently, it makes sense to take care when handling these articles to ensure that the release of dust is kept to a minimum. To ensure that the release of fibres from these R.C.F. articles is kept to a minimum, during installation & servicing we recommend that you use a HEPA filtered vacuum to remove any dust and soot accumulated in and around the fire, before and after working on the fire. When replacing these articles we recommend that the replaced items are not broken up, but are sealed within a heavy duty polythene bag, clearly labelled as "RCF waste". This is not classified as "hazardous waste" and may be disposed of at a tipping site licensed for the disposal of industrial waste. Protective clothing is not required when handling these articles, but we do recommend you follow the normal hygiene rules of not smoking, eating or drinking in the work area, and always wash your hands before eating or drinking. This appliance does not contain any component manufactured from asbestos or asbestos related products.

3.3 LIGHTING THE APPLIANCE - MANUAL CONTROL MODELS

- 3.3.1 Turn on the gas isolation tap.
- 3.3.2 Depress the control knob and turn anti-clockwise to the position marked ignition / low rate. Hold in the control knob for a few seconds to purge the pipe work.
- 3.3.3 Continue to hold-in the control knob and press the igniter button. If the burner does not light, continue to press the igniter button until ignition occurs. Continue to hold the control knob for a minimum of 20 seconds to allow the thermocouple to heat up, if the burner goes out when the control knob is released, repeat the lighting sequence.
- 3.3.4 Turn the control knob in the anti-clockwise direction to the high position and the gas rate will increase to high rate (6.5 kW)
- 3.3.5 Turn the control knob clockwise to the low position and the gas input will be reduced to the minimum setting (2.2 kW)
- 3.3.6 Slightly depress the control knob and turn to the off position, the burner will now be extinguished.

3.4 LIGHTING THE APPLIANCE - SLIDE CONTROL MODELS

- 3.4.1 Depress the control lever fully downwards to the position marked "Z". Hold down the control lever for a few seconds to allow the gas to reach the pilot.
- 3.4.2 The fire will then begin its ignition sequence. If the pilot does not light, continue to press the control lever until ignition occurs. When the pilot has lit, continue to hold the control lever down for 5-10 seconds to allow the thermocouple to heat up, before releasing the lever apply one firm downwards push to ensure that the f.s.d. valve is fully latched, if the pilot goes out when the control lever is released, repeat the lighting sequence. In the unlikely event of a failure of the igniter, firstly check the operation of the 1.5V battery and if necessary replace with a 'AA' size alkaline battery.
It is important that only an alkaline battery is used, otherwise premature battery failure and leakage may result.
- 3.4.3 After lighting, move control lever up to the high position and the main burner will light. It is recommended that for the most efficient performance the fire is allowed to warm up for a few minutes with the control lever set to the high position. The gas control can be moved from the High to Low position to give the desired heat output.

3.5 FITTING THE TRIM

3.5.1 The trim is held in position on the fixing flange by magnets.

3.6 FITTING THE FENDER

3.6.1 The fender is placed up to the front of the ceramic front rail on all models. Position the ashpan under the fender and centralise.

3.7 FITTING THE CONTEMPORARY AND 4 SIDED FASCIA'S

- 3.7.1 The fender is placed up to the front of the ceramic front rail on all models. Position the ashpan under the fender and centralise.
- 3.7.2 The contemporary trim and 4 sided fascia is held in position on the fixing flange by magnets.
- 3.7.3 To operate the fire as necessary lift the bottom bar off the rivet studs as shown below in figure 18 and re-position onto the slots as shown in figure 19 afterwards.

Fig. 18



Fig. 19

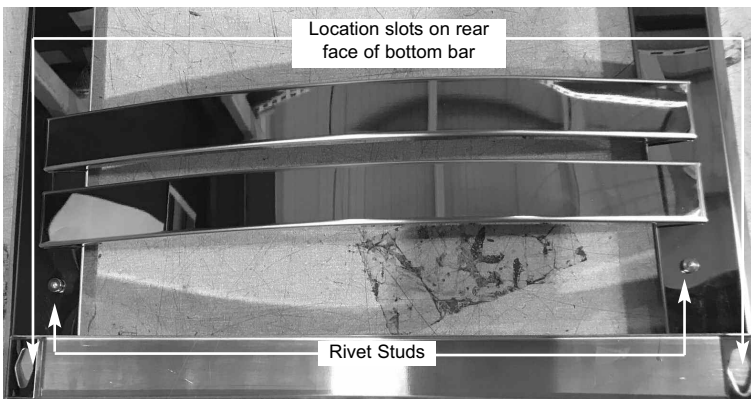

3.8 CHECKING FOR CLEARANCE OF COMBUSTION PRODUCTS

- 3.8.1 Close all doors and windows in the room.
- 3.8.2 Light the fire and allow to run for approximately 5 minutes on high position.
- 3.8.3 After approximately 5 minutes hold a smoke match 10mm inside and below the centre of the lower front edge of the top of the fire as shown overpage in figure 21. (It is recommended that a suitable smoke match holder is used when checking for clearance of combustion products). The majority of smoke generated should be drawn back into the flue. If spillage occurs or if in doubt, repeat the test after a further 10 minutes. **If the test indicates that spillage is occurring and the flue restrictor baffle has been fitted, it should be removed and the test repeated after the fire has cooled. See figure 20 below for details of how to remove and re-fit the restrictor baffle.**
- 3.8.4 If spillage persists with the restrictor baffle removed, the flue is not functioning correctly and a fault exists. If, after investigation the fault cannot be traced and rectified, the fire must be disconnected from the gas supply and expert advice obtained.
- 3.8.5 If there is an extractor fan fitted any where in the vicinity of the appliance, the spillage test should be repeated with the fan running on maximum and all interconnecting doors open.

Fig. 20

Restrictor baffle - Held in position by 2 off self tapping screws on rear spigot of fire. Restrictor baffle can be removed from below the canopy with the firebox installed

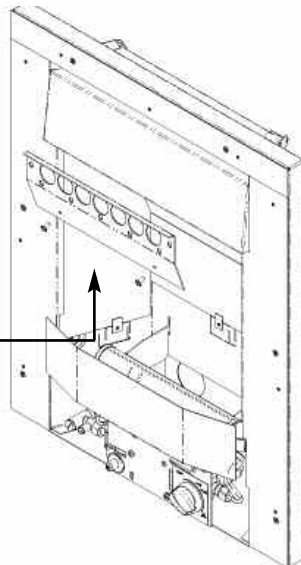

3.8.6 After ensuring that the fire is safe to use it should be left in the high position to fully warm up. During this time a slight odour may be noticed, this is due to the “newness” of the fire and will soon disappear.

At this stage any minor adjustments to the coals should be made using suitable long handled tongs and taking care not to damage the coals.

Finally, hand the Installation and Maintenance Instructions and the Users Instructions over to the customer and explain the operation of the fire.

Fig. 21

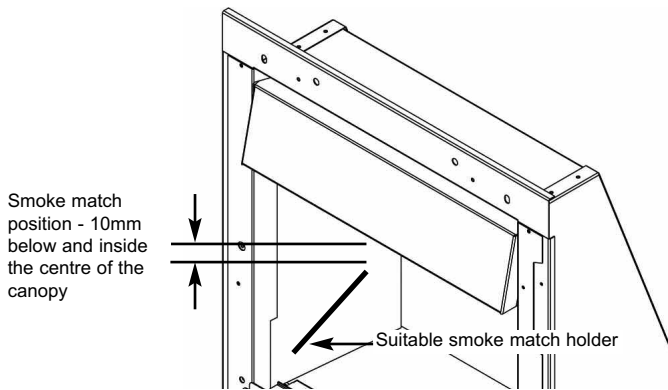

SECTION 4 MAINTENANCE

Servicing Notes

Servicing should be carried out annually by a competent person such as a GAS SAFE registered engineer. **This is a condition of the Flavel guarantee schemes.**

The service should include visually checking the chimney and fire opening for accumulations of debris and a smoke test to check for a positive up-draught in the chimney. The Oxy-pilot must also be replaced as a condition of the guarantee.

The condition of the coals / pebbles should be checked and **if necessary the whole set should be replaced with a genuine replacement set.**

The burner assembly is designed to be removed as a complete unit for ease of access. **After any servicing work a gas tightness check must always be carried out.**

Manual Control Fires – For Diagrams refer to Section 2

4.1 Removing the burner assembly from the fire.

4.1.1 Prepare work area (lay down dust sheets etc.)

4.1.2 Remove the trim. Remove the fret / ash pan cover or contemporary trim out of the way and put them in a safe location. Remove the loose coals or pebbles from the fuel bed. Remove the fuelbed matrix.

4.1.3 Isolate the gas supply and remove the inlet pipe from the appliance inlet elbow. Unscrew and remove the two screws which retain the burner at the base. Lift the burner retaining tabs from the rear of the firebox & remove the burner assembly from the fire.

4.1.4 To refit the burner assembly. Push the retaining tabs into the rear panel of the firebox and secure the burner at the base of the control panel with two screws. Refit the gas supply pipe and carry out a gas tightness test. Refit the coals or pebbles referring to section 3 for the correct layout. The trim and ash pan cover or contemporary trim can now be re-positioned.

4.2 Removing the Piezo Igniter

4.2.1 Remove the burner assembly as in section 4.1

4.2.2 Disconnect the ignition lead from the piezo and unscrew the retaining nut on the rear of the control panel. Withdraw the piezo from the front of the control panel. Re-assemble in reverse order and carry out a gas tightness test.

4.3 Removing the Control Tap from the fire.

- 4.3.1 Remove the burner assembly as in section 4.1.
- 4.3.2 Pull the control knob off the control tap spindle.
- 4.3.3 Loosen and remove the two gas pipe retaining nuts from the control tap and release the ends of the gas pipes from the control tap body. Remove the push in thermocouple from the end of the control tap.
- 4.3.4 Unscrew the control tap locknut from the front of the control panel and remove the control tap.
- 4.3.5 To refit a control tap, reassemble in reverse order noting that the control tap locates with a flat in the control panel. Carry out a gas tightness test after re-assembly.

4.4 Removing the Thermocouple

- 4.4.1 Remove the burner assembly as in section 4.1
- 4.4.2 Remove the push in thermocouple from the end of the control tap and and remove the thermocouple retaining nut from the mounting bracket on the burner assembly.
- 4.4.3 Re-assemble in reverse order and carry out a gas tightness test.

Slide Control Models – For Diagrams refer to Section 2

4.5 Removal of the burner assembly

- 4.5.1 Prepare the work area (lay down dust sheets etc.)
- 4.5.2 Remove the trim. Lift the fender and ash pan cover out of the way and put them in a safe location. Remove all of the loose coals and front ceramic rail. Unscrew the two pozi-drive fixing screws which secure the burner heat shield and remove it from the fire.
- 4.5.3 Isolate the gas supply and remove the inlet pipe from the appliance inlet elbow. The control lever operating cable can be seen running across the base of the fire, below the burner. To release the cable, unscrew the cable securing screw located in the centre of the aluminium operating arm and release the front part of the operating arm, thereby freeing the cable from the burner (see figure 27 overpage). Note the securing screw is retained in the block to prevent it from being lost. Release the other end of the cable by pushing the cable to the right, i.e. into the operating arm so as to release the tension. Remove the two retaining screws at the base of the burner unit, and the screw each side of the burner unit. The base of the burner unit can now be pulled forward, allowing the burner to be removed outwards and downwards from the fire box. Remove the burner assembly from the fire.
- 4.5.4 Refit the burner assembly to the firebox by carefully pushing the bottom of the burner back into position. Secure using the two screws into the side frame of the firebox, and two screws into the base.

It is now necessary to refit the operating arm front section to the rear section (reverse of procedure described above), when this is completed, move the control lever fully downwards and check that the left hand micro-switch operates the igniter and that the control valve spindle is fully depressed. Move the control lever upwards to the “off” position and check that the right hand (cut-off) micro-switch operates. Check that the control lever operates smoothly and safely. Refit the coals as shown in section 3, refit the fender / ashpan cover and trim.

4.6 Removal of the battery ignitor

- 4.6.1 Remove the burner assembly as above.
- 4.6.2 Disconnect the ignition lead and 2 off microswitch leads from the igniter. Unscrew the Battery retaining cap and place battery to one side. Then unscrew igniter retaining ring and remove igniter from panel. Re-assemble in reverse order and carry out a gas tightness test.

4.7 Replacing the battery

4.7.1 Unscrew Battery retaining cap situated at the front right of the fire and remove the battery

4.7.2 Replace in the reverse order using a 1.5V AA Alkaline Battery.

4.8 Removing the Oxy-Pilot Assembly

Note: Because this appliance is fitted with an atmosphere sensing 'Oxy-Pilot' it is not possible to replace the thermocouple separately, because the thermocouple position is factory set to a tight tolerance. Any replacement of parts on the pilot requires a complete new pilot assembly.

4.8.1 Remove the burner assembly as in section 4.1

4.8.2 Unscrew and remove the thermocouple retaining nut from the end of the control tap, disconnect the ignition lead from the pilot electrode and the two inline leads from the microswitch.

4.8.3 Unscrew and remove the two pozi-drive screws which secure the pilot assembly to the burner. Remove the pilot.

4.8.4 Re-assemble in reverse order and carry out a gas tightness test.

4.9 Replacing the Control Cable

4.9.1 The control lever operating cable can be seen running across the base of the fire, below the burner. To release the cable, unscrew the cable securing screw located in the centre of the aluminium operating arm and release the front part of the operating arm, thereby freeing the cable from the burner. See figure 22 below.

Fig. 22

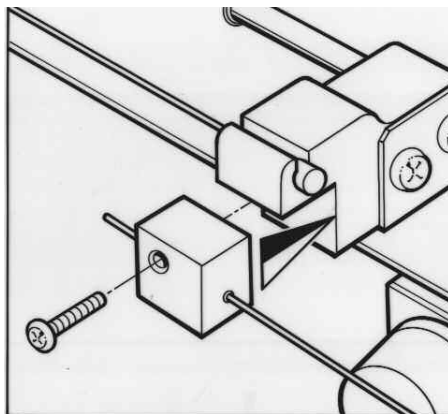

- 4.9.2 Hold the hexagonal control lever cable locking bush with a spanner and unscrew the locking screw using a 2mm allen key to release the cable from the control lever. The control cable can now be removed from the cable guide tubes.
- 4.9.3 To fit the replacement cable, thread the end of the new cable into the long length of p.t.f.e. sleeve (as supplied) , taking care not to kink the sleeve. Now carefully feed the sleeve and cable into the left hand cable guide tube until the ends emerge above the control lever. Now thread the short length of p.t.f.e. sleeve over the end of the cable and thread the sleeve and cable into the top of the short cable guide tube.
- 4.9.4 When the end of the cable emerges from the short cable guide tube, locate the nipple on the other end of the cable into the locating hole in the aluminium operating arm. Thread the free end of the cable into the cable retaining hole on the operating arm, but at this stage do not tighten the securing screw.
- 4.9.5 Fit the hexagonal control lever cable locking bush onto the control lever and fit the control cable loosely into the bush in the gap between the two lengths of p.t.f.e. sleeve. Ensure that the cable is located in the retaining hole in the locking bush and tighten the screw sufficiently to retain the cable but still allowing it to slide for adjustment.
- 4.9.6 It is now necessary to correctly tension the operating cable. To do this, first set the control lever to the horizontal (central position), this is the position which creates maximum tension in the operating cable. Pull the free end of the operating cable through the operating arm until it is finger tight and secure with screw into operating arm (do not over tighten).
- 4.9.7 Slide the operating arm fully to the right hand position and hold in position, slide the control lever relative to the cable until the cable retaining screw lines up with the hole in the flange. This sets the control lever in the correct position. Hold the hexagonal locking bush with a spanner and tighten the retaining screw using the 2mm allen key. Move the control lever fully downwards and check that the left hand micro-switch operates the igniter and that the control valve spindle is fully depressed. Move the control lever upwards to the "off" position and check that the right hand (cut-off) micro-switch operates. Check that the control lever operates smoothly and safely.

PARTS SHORTLIST

Replacement of parts must be carried out by a competent person such as a GAS SAFE registered gas installer. The part numbers of the replaceable parts are as follows, these are available from BFM Europe who may be contacted at the address shown on the rear cover.

Complete coal / ceramic set	B-67400
Coal fuel-bed matrix	B-67040
Replacement coal set	B-67050
Complete pebble / ceramic set	B-68220
Pebble fuelbed base	B-68230
Replacement pebble set	B-68240
Piezo igniter	B-1320
Manual gas valve	B-67090
Manual ignition wire	B-67910
Slide control ignition wire	B-34690
Slide control gas valve	B-40980
Slide control ODS pilot	B-19660

SECTION FIVE - USER INSTRUCTIONS

5.1 INSTALLATION INFORMATION

CONDITIONS OF INSTALLATION

It is the law that all gas appliances are installed only by a competent (e.g. GAS SAFE registered) Installer, in accordance with the installation instructions and the Gas Safety (Installation and Use) Regulations 1998. Failure to install appliances correctly could lead to prosecution. It is in your own interest and that of safety to comply with the law.

The fire may be fitted below a combustible shelf provided that the shelf is at least 200mm above the top of the appliance and the depth of the shelf does not exceed 150mm.

The fire may be installed below combustible shelves which exceed 150mm deep providing that the clearance above the fire is increased by 15mm for each 25mm of additional overhang in excess of 150mm.

No purpose made additional ventilation is normally required for this appliance when installed in G.B. When installed I.E. please consult document I.S. 813 : 1996 Domestic Gas Installation which is issued by the National Standards Authority of Ireland. Any purpose made ventilation should be checked periodically to ensure that it is free from obstruction.

If the chimney or flue has been previously used by appliances burning fuels other than gas they must be swept prior to the installation of this fire.

If this appliance is fitted directly on to a wall without the use of a fireplace or surround, soft wall coverings such as wallpaper, blown vinyl etc. could be affected by the heat and hot convection air and may discolour or scorch. This should be considered when installing or decorating.

The Model number of this appliance is as stated on the rating plate affixed to the control panel of the fire and the appliance is manufactured by:-

BFM Europe Ltd
Trentham Lakes
Stoke on Trent
ST4 4TJ

ABOUT YOUR NEW FLAVEL WINDSOR / STIRLING PLUS GAS FIRE

The The Flavel Windsor & Stirling Plus coal effect gas fires incorporate a unique and highly developed fuel bed which gives the realism of a loose coal layout combined with realistic flames and glow. The use of durable ceramic material in the construction of the fuelbed components ensures long and trouble free operation. When first using the new fire a slight smell may be noticed. This is due to starch used in the manufacture of the soft ceramic coals / pebbles, it is non-toxic and will soon disappear.

Please take the time to fully read these instructions as you will then be able to obtain the most effective and safe operation of your fire.

IMPORTANT SAFETY INFORMATION

WARNING

This appliance has a naked flame and as with all heating appliances a fireguard should be used for the protection of children, the elderly and infirm. Fireguards should conform to B.S. 8423 : 2002 (Fireguards for use with gas heating appliances).

It is important that this appliance is serviced at least once a year by a GAS SAFE registered installer and that during the service the fire is removed from the fire opening and the chimney or flue visually checked for fallen debris or blockages which must be removed. The chimney should also be checked to ensure clearance of flue products.

After installation or during servicing a spillage test must always be carried out.

Rubbish of any type must NEVER be thrown onto the fuel bed, this could affect safe operation and damage the fire.

Any debris or deposits should be removed from the fuel bed from time to time. This may be carried out by referring to the cleaning section as described later in this book.

Only the correct number and type of coals / pebbles must be used and only complete and genuine replacement sets must be used.

Always keep furniture and combustible materials well clear of the fire and never dry clothing or items either on or near to the fire. Never use aerosols or flammable cleaning products near to the fire when it is in use.

The ceramic fuel bed remains hot for a considerable period after use and sufficient time should be allowed for the fire to cool before cleaning etc.

5.2 OPERATING THE FIRE - MANUAL CONTROL MODELS

- 5.2.1 The controls are located behind the ashpan cover which is situated below the fret or contemporary ashpan cover. The controls, comprise a control valve to adjust the gas flow and a push button piezo igniter. To light the fire proceed as follows:-
- 5.2.2 Depress the control knob and turn anti-clockwise to the position marked ignition rate. Hold in the control knob for a few seconds to allow the gas to reach the burner.
- 5.2.3 Continue to hold-in the control knob and press the igniter button. If the burner does not light, continue to press the igniter button until ignition occurs. When the pilot has lit, continue to hold the control knob in for a minimum of 20 seconds to allow the thermocouple to heat up, if the burner goes out when the control knob is released, repeat the lighting sequence.
- 5.2.4 In the unlikely event of a failure of the igniter, the fire can be lit as follows :- Depress the control knob and turn anti-clockwise to the position marked ignition rate. Hold in the control knob for a few seconds to allow the gas to reach the burner. Insert the tip of a lit taper in below the fuelbed ceramic matrix above the thermocouple tip. This will light the main burner at low rate (2.2kW)
- 5.2.5 After lighting, turn the control knob in the anti-clockwise direction to the high position (6.5kW). It is recommended that for most efficient performance the fire is allowed to warm up for a few minutes with the gas control on maximum.
- 5.2.6 The gas control can be turned clockwise from the maximum position to give the desired heat output.

WARNING : If the fire goes out for any reason or is turned off and it is necessary to re-light the fire it is important to allow the fire to cool for 3 minutes before attempting to re-light it.

5.3 OPERATING THE FIRE - SLIDE CONTROL MODELS

The control comprises a control lever, to turn the fire on and off and adjust the gas rate. The control lever is located at the top right hand side of the fire. Depressing the control lever fully operates the igniter and lights the pilot flame and ignition rate gas. Once the pilot is established raising the lever allows medium and finally high gas settings. The fire is turned off when the control lever is fully raised. To light the fire proceed as follows :-

- 5.3.1 Depress the control lever fully downwards to the position marked "Z". Hold down the control lever for a few seconds to allow the gas to reach the pilot.
- 5.3.2 The fire will then begin its ignition sequence. If the pilot does not light, continue to press the control lever until ignition occurs. When the pilot has lit, continue to hold the control lever down for 5-10 seconds to allow the thermocouple to heat up, before releasing the lever apply one firm downwards push to ensure that the f.s.d. valve is fully latched, if the pilot goes out when the control lever is released, repeat the lighting sequence.

In the unlikely event of a failure of the igniter, firstly check the operation of the 1.5V battery and if necessary replace with a 'AA' size alkaline battery.

It is important that only an alkaline battery is used, otherwise premature battery failure and leakage may result. |

- 5.3.3 After lighting, move control lever up to the high position and the main burner will light. It is recommended that for the most efficient performance the fire is allowed to warm up for a few minutes with the control lever set to the high position.
- 5.3.4 The gas control can be moved from the High to Low position to give the desired heat output.

5.4 REPLACING THE BATTERIES ON SLIDE CONTROL MODELS

- 5.4.1 Remove the ashpan cover, locate the battery holder / ignition generator unit at the centre of the control panel below the burner.
- 5.4.2 Unscrew the retaining cap, remove and replace the 1 off AA battery, then replace the retaining cap. BFM Europe recommend the use of "Energizer" batteries. **It is important that only an alkaline battery is used, otherwise premature battery failure and leakage may result.**

5.5 SPILLAGE MONITORING SYSTEM

All models regardless of control type are fitted with a spillage monitoring system which shuts down the fire if the evacuation of combustion products from the fire is affected by a partially or fully blocked flue. If this system operates the fire will go out. If this occurs, leave the fire for at least three minutes then follow the lighting procedure as described in the previous section. **In the event of repeated operation a GAS SAFE registered gas engineer must be called to investigate and rectify the cause.**

5.6 CLEANING - WARNING

Before attempting any cleaning operation ensure that the fire has been allowed to fully cool.

5.6.1 CLEANING THE TRIMS AND PAINTED METAL PARTS

Dependent upon the trim option chosen for use with this fire, there is a variety of methods that can be chosen to clean the trim. If a Brass trim was supplied with this fire this is plated brass and this trim must only be cleaned using a clean damp cloth. Metal polishes must not be used on these trims. If a black trim was chosen, then these should only be cleaned using a clean, damp cloth also. The trim is best cleaned by removing it from the fire and placing it face up on a flat surface. The fender that was supplied with the fire is laquered to protect the finish and therefore must only be cleaned using a clean damp cloth.

Abrasive cleaners, chemical cleaning agents or any type of polish must never be used as damage to the finish may result.

5.6.2 CLEANING THE FUEL BED

We do not recommend cleaning of coals / pebbles or fuelbed components as these are fragile and damage may result. **None of these parts must be washed or exposed to any cleaning agents or water.** Any damaged parts must be replaced by contacting your dealer or telephoning BFM Europe Ltd on the number stated on the rear cover of this book. Coals / pebbles must only be replaced with a complete and genuine replacement set and the fire must never be run with the wrong number or damaged coals. The fuelbed must be carefully re-assembled as stated in the following section.

5.7 RE-ASSEMBLING THE FUEL-BED - COAL MODELS

- 5.7.1 Place the fuelbed base centrally on to the fuelbed support and push fully backwards to the rear face of the fibre boards **Make sure that the fuelbed base is located centrally in the fire box, behind the retaining tabs** as shown below in figure 1.

Fig. 1

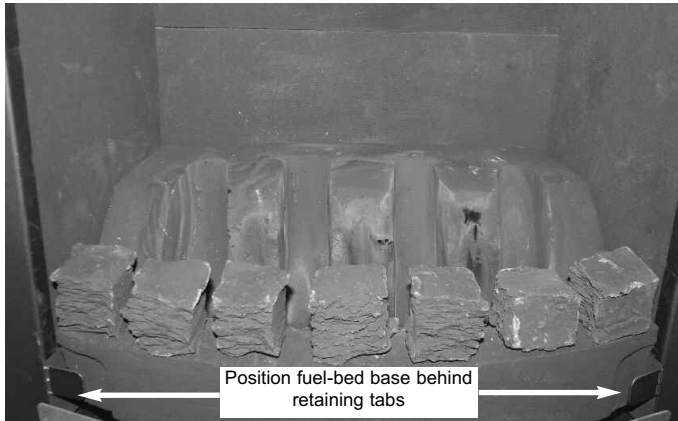

- 5.7.2 Position the front row of four large loose coals along behind the first row of coals, ensuring that the flame paths as indicated are not interrupted. See figure 2 below.

Fig. 2

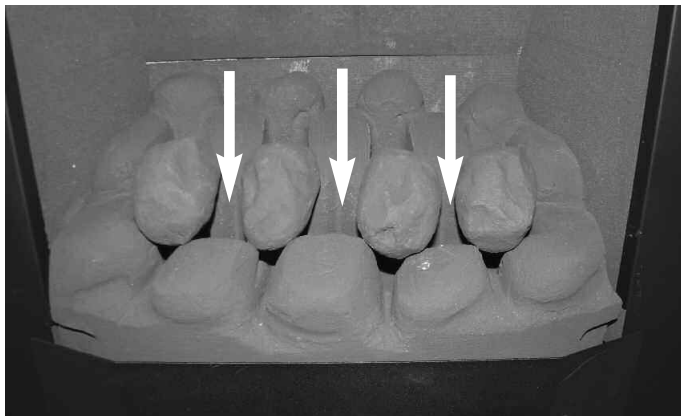

- 5.7.3 Select 3 off coals and arrange along the rear of the fuelbed, using the ribs in the rear of the fuelbed as a guide for placement, see figure 3 below.

Fig. 3

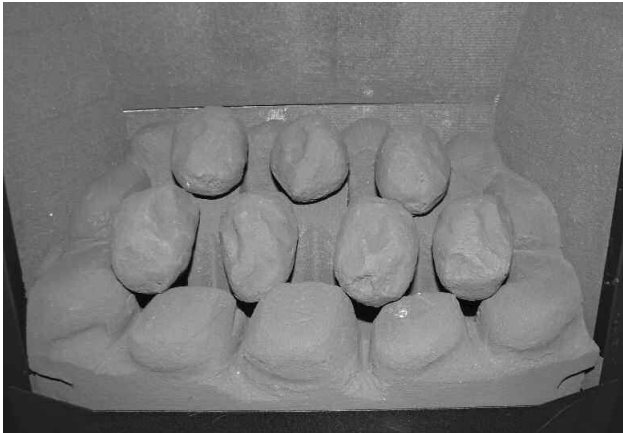

The exact position and fit of the coals may be finely adjusted to give the best appearance.

Warning : Use only the coal set supplied with the fire. When replacing the coals remove the old coals and discard them. Fit a complete set of coals of the correct type. Do not fit additional coals or any coals other than a genuine replacement set.

This appliance uses fuel effect pieces containing Refractory Ceramic Fibres (R.C.F.), which are man-made vitreous silicate fibres. Excessive exposure to these materials may cause temporary irritation to eyes, skin and respiratory tract. Consequently, it makes sense to take care when handling these articles to ensure that the release of dust is kept to a minimum. To ensure that the release of fibres from these R.C.F. articles is kept to a minimum, during installation & servicing we recommend that you use a HEPA filtered vacuum to remove any dust and soot accumulated in and around the fire, before and after working on the fire. When replacing these articles we recommend that the replaced items are not broken up, but are sealed within a heavy duty polythene bag, clearly labelled as "RCF waste". This is not classified as "hazardous waste" and may be disposed of at a tipping site licensed for the disposal of industrial waste. Protective clothing is not required when handling these articles, but we do recommend you follow the normal hygiene rules of not smoking, eating or drinking in the work area, and always wash your hands before eating or drinking. This appliance does not contain any component manufactured from asbestos or asbestos related products.

5.9 RE-ASSEMBLING THE FUEL-BED - PEBBLE MODELS

- 5.9.1 Place the fuelbed base centrally on to the fuelbed support and push fully backwards to the rear face of the fibre boards **Make sure that the fuelbed base is located centrally in the fire box, behind the retaining tabs** as shown below in figure 4.

Fig. 4

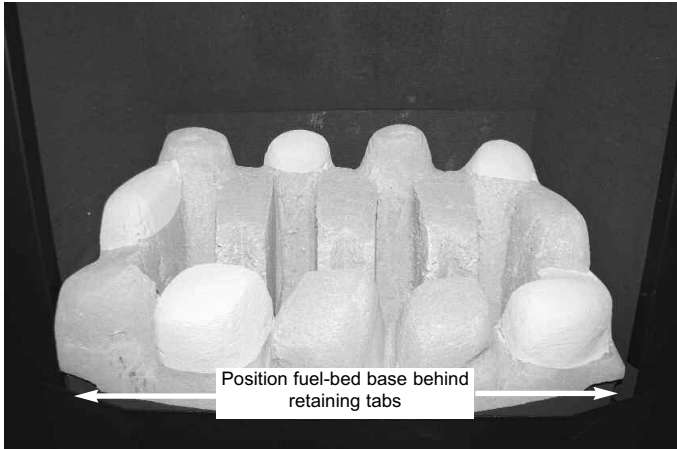

- 5.9.2 Position the front row of four large loose pebbles along behind the first row of pebbles, ensuring that the flame paths as indicated are not interrupted. See figure 5 below.

Fig. 5

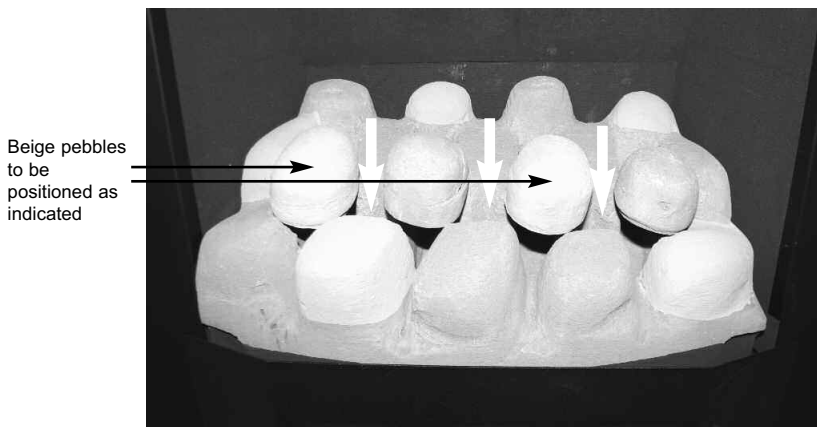

5.9.3 Fit the three small pebbles onto the ribs in the fuelbed as shown below, ensuring that the rear flame paths as indicated are not interrupted. See figure 6 below.

Fig. 6

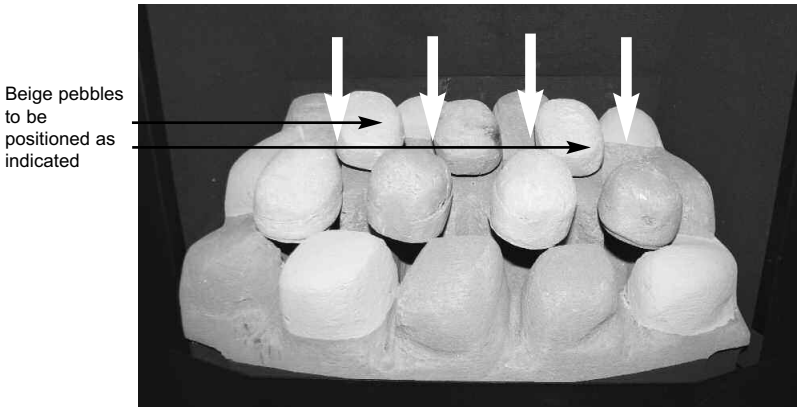

The exact position and fit of the pebbles may be finely adjusted to give the best appearance.

Warning : Use only the pebble set supplied with the fire. When replacing the pebbles remove the old pebbles and discard them. Fit a complete set of pebbles of the correct type. Do not fit additional pebbles or any pebbles other than a genuine replacement set.

This appliance uses fuel effect pieces containing Refractory Ceramic Fibres (R.C.F.), which are man-made vitreous silicate fibres. Excessive exposure to these materials may cause temporary irritation to eyes, skin and respiratory tract. Consequently, it makes sense to take care when handling these articles to ensure that the release of dust is kept to a minimum. To ensure that the release of fibres from these R.C.F. articles is kept to a minimum, during installation & servicing we recommend that you use a HEPA filtered vacuum to remove any dust and soot accumulated in and around the fire, before and after working on the fire. When replacing these articles we recommend that the replaced items are not broken up, but are sealed within a heavy duty polythene bag, clearly labelled as "RCF waste". This is not classified as "hazardous waste" and may be disposed of at a tipping site licensed for the disposal of industrial waste. Protective clothing is not required when handling these articles, but we do recommend you follow the normal hygiene rules of not smoking, eating or drinking in the work area, and always wash your hands before eating or drinking. This appliance does not contain any component manufactured from asbestos or asbestos related products.

USER REPLACEABLE PARTS

The only user replaceable parts on this fire are the fuelbed components and coals / pebbles which may be replaced as described in the above section. Replacement of any other parts must be carried out by a competent person such as a GAS SAFE registered gas installer.

The part numbers of the user replaceable parts are as follows, these are available from BFM Europe Ltd whose contact details may be found overpage.

Complete coal / ceramic set	B-67400
Coal fuel-bed matrix	B-67040
Replacement coal set	B-67050
Complete pebble / ceramic set	B-68220
Pebble fuelbed base	B-68230
Replacement pebble set	B-68240

Due to our policy of continual improvement and development the exact accuracy of illustrations and descriptions contained in this book cannot be guaranteed.

Part No. B-1002337
Issue 5



At the heart of your home

BFM Europe Ltd.
Trentham Lakes
Stoke-on-Trent
Staffordshire
ST4 4TJ

www.bfm-europe.com

Telephone - General Enquiries :
Telephone - Service :

(01782) 339000
(01782) 339008