



At the heart of your home

# Kenilworth HE, Linear HE, Diamond HE & Expression HE

## INSET LIVE FUEL EFFECT GAS FIRE

### Installation, Maintenance & User Instructions

**Hand these instructions to the owner following installation, they must be retained for future reference.**

Model No's FHKC\*\*MN2, FHKC\*\*RN3, FHLC\*\*MN2, FHLP\*\*MN2, FHDC\*\*RN3, FHDP\*\*RN3 & FHKCEHRN are only for use on Natural Gas (G20) at a supply pressure of 20 mbar in G.B. / I.E.

\*\* denotes trim and fret variant

## Information Requirements for Commission Regulation (EU) 2015/1188

<b>Model Identifier</b>	<b>FHKC**MN2, FHKC**RN3, FHLC**MN, FHLP**MN2, FHDC**RN3, FHDP**RN3 &amp; FHKCEHRN</b>
<b>Indirect Heating Functionality</b>	<b>No</b>
<b>Direct Heat Output</b>	<b>3.4kW</b>
<b>Indirect Heat Output</b>	<b>Not Applicable</b>
<b>Fuel</b>	<b>Natural Gas (G20)</b>
<b>NOx Emissions</b>	<b>130mg/kWh</b>
<b>Nominal Heat Output</b>	<b>3.4kW</b>
<b>Minimum Heat Output (Indicative, all models)</b>	<b>1.8kW</b>
<b>Useful Efficiency at Nominal Heat Output</b>	<b>84.3%</b>
<b>Useful Efficiency at Minimum Heat Output (Indicative)</b>	<b>50.0%</b>
<b>Auxilliary power consumption at nominal heat output - manual &amp; slide control models</b>	<b>Not applicable</b>
<b>Auxilliary power consumption at nominal heat output - remote control models</b>	<b>0.000001kW</b>
<b>Auxilliary power consumption at minimum output - manual &amp; slide control models</b>	<b>Not applicable</b>
<b>Auxilliary power consumption at minimum output - remote control models</b>	<b>0.000001kW</b>
<b>Auxilliary power consumption at standby mode - manual &amp; slide control models</b>	<b>Not applicable</b>
<b>Auxilliary power consumption at standby mode - remote control models</b>	<b>0.0000005kW</b>
<b>Permanent pilot flame requirement</b>	<b>Not applicable</b>
<b>Type of heat output / room temperature</b>	<b>Two or more manual control stages, no room temperature control - manual control models</b>
	<b>With electronic room temperature control - remote control models</b>
<b>Contact Details</b>	<b>BFM Europe Ltd, Gordon Banks Drive, Trentham Lakes North Stoke-on-Trent, ST4 4TJ. Tel : 01782 339000</b>

## CONTENTS

	<b>PAGE</b>
<b>Section 1 Information and Requirements</b>	
1.0 Appliance Information	3
1.1 Conditions of Installation	4
1.2 Flue and chimney suitability	4
1.3 Fireplace / surround suitability	5
1.4 Shelf position	5
1.5 Chimney inspection	5-6
1.6 Fire place opening / catchment space	6-7
1.7 Fitting to metal flue boxes	7
1.8 Fitting to pre-cast flues	8
1.9 Spillage monitoring system	8
1.10 Wall / hearth mounting	9
<b>Section 2 Installation of Fire</b>	
2.1 Unpacking the fire	9
2.2 Installing the fire box	10-19
2.3 Gas tightness and inlet pressure (MC models)	19
2.4 Gas tightness and inlet pressure (SC models)	20
2.5 Gas tightness and inlet pressure (RC models)	20
<b>Section 3 Assembling Fuel Bed and Commissioning</b>	
3.1 Assembling the ceramics and fuel bed - coal models	20-25
3.2 Assembling the ceramics and fuel-bed - pebble models	26-30
3.3 Lighting the appliance (manual control model)	30-31
3.4 Lighting the appliance (slide control model)	31
3.5 Fitting the batteries (remote control models)	32-33
3.6 Lighting the fire manually via the control valve (remote control models)	33
3.7 Setting the time, temperature and day on the remote handset (remote models)	34-37
3.8 Lighting the fire via the remote handset (remote control models)	38-41
3.9 Advanced settings of remote control models	41-45
3.10 Fitting the trim / fret or fascia	45
3.11 Checking for clearance of combustion products	46
<b>Section 4 &amp; 5 Maintenance</b>	
4.1 Removal of the burner assembly (manual control models)	47
4.2 Removal of the piezo igniter (manual control models)	48
4.3 Removal of the control tap (manual control models)	48
4.4 Removal of the pilot assembly (manual control models)	48-49
4.5 Removal of the burner assembly (slide control models)	49-50
4.6 Removal of the battery ignitor (slide control models)	50
4.7 Replacing the battery (slide control models)	50
4.8 Removing the oxy-pilot assembly (slide control models)	50-51
4.9 Replacing the control cable (slide control models)	51-52
5.1 Removal of the burner assembly (remote control models)	52
5.2 Removing the remote gas valve	52-53
5.3 Removing the oxy-pilot assembly (remote control models)	53
5.4 Replacing the batteries (remote control models)	53
5.5 Fret Information / parts shortlist	54
<b>Section 6 User Instruction Section</b>	
6.1 Conditions of Installation & about your new fire	55-56
6.2 Operating the fire - manual, slide & remote control variants	57-63
6.3 Manual operation of remote control models	64-65
6.4 Replacing the batteries on remote control models	65
6.5 Replacing the batteries on slide control models	65
6.6 Spillage monitoring system	66
6.7 Setting the time, day & temperature on the remote handset	67-70
6.8 Advanced settings menu of the remote control	71-74
6.9 Re-assembling the ceramics & fuel-bed - coal models	75-79
6.10 Re-assembling the ceramics & fuel-bed - pebble models	80-84
6.11/12 Cleaning the fire & fuel-bed / glass panel	84-85
6.13 Removal & re-fitting of the glass panel	86-87
6.14 Removal & re-fitting the trim / fret	88
6.15 User replaceable parts	88

## SECTION 1 INFORMATION AND REQUIREMENTS

### 1.0 APPLIANCE INFORMATION

Model	FHKC**MN2 FHLC**MN2 FHLP**MN2 FHDC**RN3 FHDP**RN3 FHKCEHRN
Gas type	G20
Main injectors (2 off)	Size 130 (MC) 170 (RC)
Pilot type (MC)	Copreci 21100 / 141
Pilot type (RC)	ERTA OXYP PG-83-10
Max. gross heat input :	4.5 kW
Min. gross heat input :	3.5 kW
Cold pressure :	20.0 +/- 1.0 mbar
Ignition :	Push button piezo (MC models) 1.5V battery generator (SC models) 4.5V battery generator (RC models)
Electrode spark gap	4.5mm nominal
Weight	20kg (all models)

**Fire box Dimensions (with standard trim) - for all other models please consult manufacturer**

Width :	(with standard trim)	498mm
Height :	(with standard trim, no spacer)	600mm
Depth :	(overall-without fender)	180mm
Depth :	Flush-fit (from mounting face to rear)	180mm
Depth :	Flush-fit (mounting face to rear with 50mm spacer fitted)	130mm

Gas Connection            8mm Compression            (Supplied with fire)

This appliance is manufactured by :-  
BFM Europe Ltd, Trentham Lakes, Stoke-on-Trent, ST4 4TJ

#### **Appliance Efficiency Declaration**

**The efficiency of this appliance has been measured as specified in BS 7977-1 : 2009 + A1 : 2013 and the result is 76.6%. The gross calorific value of the fuel has been used for this efficiency calculation.**

**The test data from which it has been calculated has been certified by BSI. The efficiency value may be used in the UK Government's Standard Assessment Procedure (SAP) for energy rating of dwellings.**

# INSTALLATION REQUIREMENTS

## 1.1 CONDITIONS OF INSTALLATION

It is the law that all gas appliances are installed only by a Registered Installer, in accordance with these installation instructions and the Gas Safety (Installation and Use) Regulations 1998 as amended. Failure to install appliances correctly could lead to prosecution. It is in your own interest and that of safety to comply with the law.

The installation must also be in accordance with all relevant parts of the Local and National Building Regulations where appropriate, the Building Regulations (Scotland Consolidation) issued by the Scottish Development Department, and all applicable requirements of the following British Standard Code of Practice.

1. BS 5871 Part 2 Installation of Inset Fuel Effect Gas Fires
2. BS 6891 Installation of Gas Pipework
3. BS 5440 Parts 1 & 2 Installation of Flues and Ventilation
4. BS 1251 Open fire place components
5. BS 715 / BS EN 1856-2 Metal flue pipes for gas appliances
6. BS 6461 Part 1 Installation of masonry chimneys and flues
7. IS 813 : 1996 Domestic Gas Installation (Republic of Ireland)

**No purpose made additional ventilation is normally required for this appliance, when installed in G.B. When installing in I.E. please consult document I.S. 813 : 1996 Domestic Gas Installation, which is issued by the National Standards Authority of Ireland. If installing in Northern Ireland, please consult local building regulations. In Scotland, please consult the current edition of the Building standards regulations, issued by the Scottish Executive. Any purpose made ventilation must be checked periodically to ensure that it is free from obstruction.**

## 1.2 FLUE AND CHIMNEY SUITABILITY

This appliance is designed for use with conventional brick built or lined chimneys and fabricated flues and metal flue boxes conforming to BS 715 / BS EN 1856-2. All flues must conform to the following minimum dimensions.

<b>Minimum diameter of circular flues</b>	<b>125 mm (Without flue restrictor fitted)</b>
<b>Minimum effective height of all flue types</b>	<b>4 metres</b>

**When fitting to conventional chimneys or 175mm flues it may be desirable to fit the flue restrictor baffle (supplied) to reduce the flue flow and increase the efficiency of the fire. Safe clearance of products must always be checked by carrying out a smoke match test as described.**

### 1.3 FIREPLACE / SURROUND SUITABILITY

The fire must only be installed on a hearth it **must not be installed directly onto carpet or other combustible floor materials.** The fire is suitable for fitting to non-combustible fire place surrounds and proprietary fire place surrounds with a temperature rating of at least 150°C. (Class “O”)

**If a heating appliance is fitted directly against a wall without the use of a fire surround or fire place all combustible material must be removed from behind the trim. Soft wall coverings such as blown vinyl, wall paper etc. could be affected by the rising hot air and scorching and / or discoloration may result. Due consideration should be made to this when installing or decorating.**

### 1.4 SHELF POSITION

The fire may be fitted below a combustible shelf providing there is a minimum distance of 200mm above the top of the fire and the shelf does not project more than 150mm. If the shelf overhangs more than 150mm the distance between the fire and the shelf must be increased by 15mm for every 25mm of additional overhang over 150mm.

### 1.5 FLUE / CHIMNEY INSPECTION

Before commencing installation, a flue or chimney should be inspected to ensure that all the following conditions are satisfied.

1. Check that the chimney / flue only serves one fire place and is clear of any obstruction. Any dampers or register plates must be removed or securely locked in the open position.
2. Brick / stone built chimneys or any chimney or flue which has been used for an appliance burning fuel other than gas must be thoroughly swept. The base of the chimney / flue must also be thoroughly cleared of debris etc.
3. Any under-floor air supply to the fire place must be completely sealed off.
4. Ensure that the inside of the chimney / flue is in good condition along its length and check that there is no leakage of smoke through the structure of the chimney during and after the smoke pellet test.
5. **Using a smoke pellet, check that there is an up-draught in the chimney / flue and that the smoke can be seen issuing from the terminal / chimney pot outside. There must be no leakage of smoke through the structure of the chimney during or after the smoke pellet test and it is important to check inside upstairs rooms adjacent to the chimney / flue.**

Check the chimney pot / terminal and general condition of the brickwork or masonry. If the chimney or flue is in poor condition or if there is no up-draught do not proceed with the installation. If there is a history of down-draught conditions with the chimney / flue, a tested and certificated flue terminal or cowl suitable for the relevant flue type should be considered.

6. **A spillage test must always be carried out during commissioning of the appliance.**

### 1.6 FIRE PLACE OPENING AND CHIMNEY CATCHMENT SPACE

The front opening of the fire place must be between 370 and 450 mm wide, and between 550 and 570mm high. If the opening exceeds these dimensions then a surround must be constructed from suitable non-combustible material to produce a correct size opening. Any surround must be suitably sealed to the fire place to prevent leakage. See below in fig.1

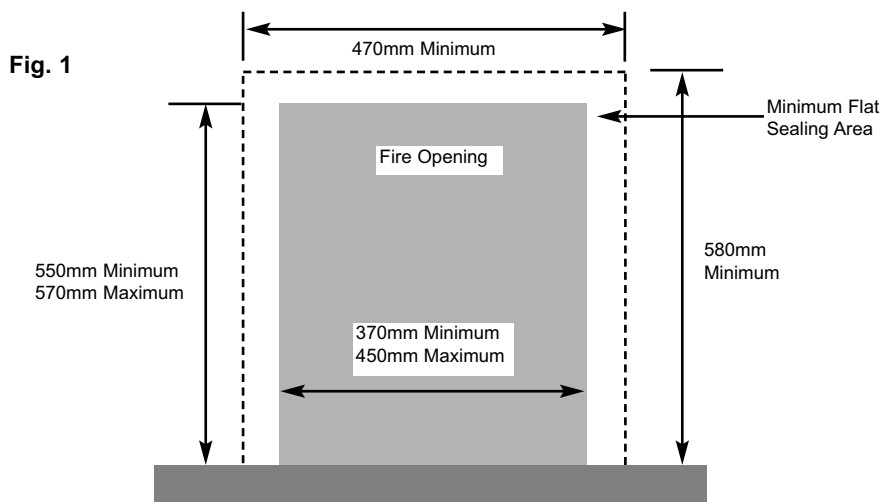

When installing into a brick built chimney, you must ensure that there is sufficient depth to accommodate any debris which may fall from the chimney. This depth must be sufficient to accommodate 12 litres of volumetric space.

**Table A - Installation Depth Requirements for a Flavel Kenilworth, HE, Linear HE, Diamond HE or Expression HE being installed into a brick built chimney, requiring 12.0 litres of debris collection volume (figure 2).**

When installing this product into a brick built chimney, there must be a minimum depth available of 200mm available for the collection of debris behind the firebox when installed.

See figure 2 below for explanatory diagram.

**Fig. 2**

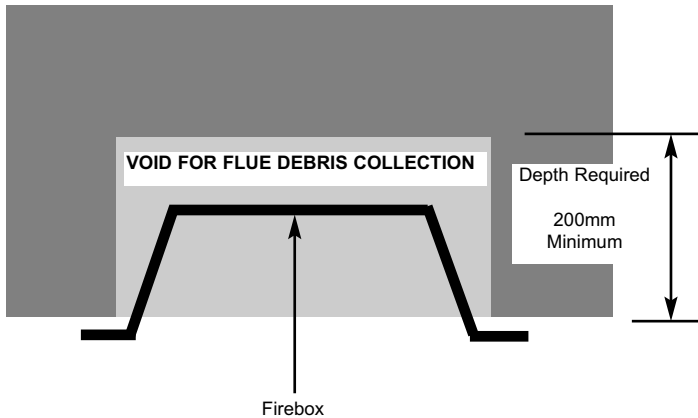

### **1.7 FITTING TO PRE-FABRICATED TWIN WALL METAL FLUE BOXES**

The appliance may be fitted to twin wall metal flue boxes conforming to the constructional requirements of BS 715, (for example the Selkirk LFE 175 box). The box must have a minimum flue diameter of 125mm internal and minimum internal dimensions of 275mm deep by 580mm high by 400mm wide. The top face of the box must be insulated with a minimum thickness of 50mm of non-combustible mineral wool insulation or similar material. The flue box must stand on a non-combustible base of minimum thickness 12mm if the flue box being utilised is of single skin construction.



## 1.8 FITTING TO PRE-CAST FLUES

**When installing this appliance into pre-cast flues, always ensure that the spigot restrictor baffle has been removed.**

**To install the fire box in to pre-cast flue starter blocks, there must be at least 180mm from the mounting face of the fire to the rear of the pre-cast flue starter block** to allow sufficient space for debris collection. It is important to consider this depth when choosing a fire surround as the thickness of the fire surround must be sufficient to give a total depth of **at least 180 mm to the rear of the starter block**, otherwise there will be insufficient depth. To increase this depth the optional black 50mm spacer frame may be purchased, this will reduce the depth required to **130mm** or the fire surround may be packed away from the wall using suitable non-combustible board, providing the installation is correctly sealed. If in doubt about the suitability of the fire contact the manufacturer for advice before proceeding. **This fire has been designed to fit standard 100mm pre-cast starter blocks with 3 inch rebated surrounds and a 10mm plaster wall covering.** It is important to ensure that the pre-cast flue is in good condition and is free from extruded mortar or sealant from between the flue blocks.

**This appliance has been tested for use in a pre-cast flue block complying with BS EN 1858. In accordance with BS EN 1858, pre-cast flues built with directly plastered faces (front or rear) are not correctly installed as to ensure proper operation with any type of gas fire. In some instances of this flue construction, temperature cracking of surface plaster may occur through no fault of the appliance. An air gap or some form of insulation material should be installed to prevent normal flue temperatures from damaging wall surfaces.**

## 1.9 SPILLAGE MONITORING SYSTEM

This appliance is fitted with an atmosphere sensing spillage monitoring system in the form of an oxygen sensing pilot. This is designed to shut the fire off in the event of a partial or complete blockage of the flue causing a build up of combustion products in the room in which the fire is operated. **The following are important warnings relating to this spillage monitoring system :-**

- 1) The spillage monitoring system must not be adjusted by the installer.
- 2) The spillage monitoring system must not be put out of operation.
- 3) When the spillage monitoring system is exchanged only a complete original manufacturers part may be fitted. It is not possible to replace individual parts on the pilot system on this appliance, only a complete pilot assembly (including the thermocouple) may be fitted.

## 1.10 WALL / HEARTH MOUNTING

This appliance must be fitted on a flat, non-combustible base of minimum thickness 12mm. In addition, a non-combustible hearth or physical barrier should be provided in front of the fire.

With “hole in the wall” type installations, where it may be desirable not to fit a hearth panel or physical barrier, the product may be installed in accordance with Document J of the building regulations so that every part of the flame or incandescent material is at least 225mm above the floor level. For the customers safety, and in accordance with BS 5871-2, the fitting of a hearth panel or physical barrier should be carried out. Should this advice not be followed however, please give consideration to the safety of the occupants in the room to which the appliance is installed.

Any hearth panel or physical barrier that is fitted should project a minimum of 300mm forwards from the fire opening and 150mm either side of the fire opening, as shown below in figure 3. Any physical barrier must be securely fixed and be of robust design.

**Fig. 3**

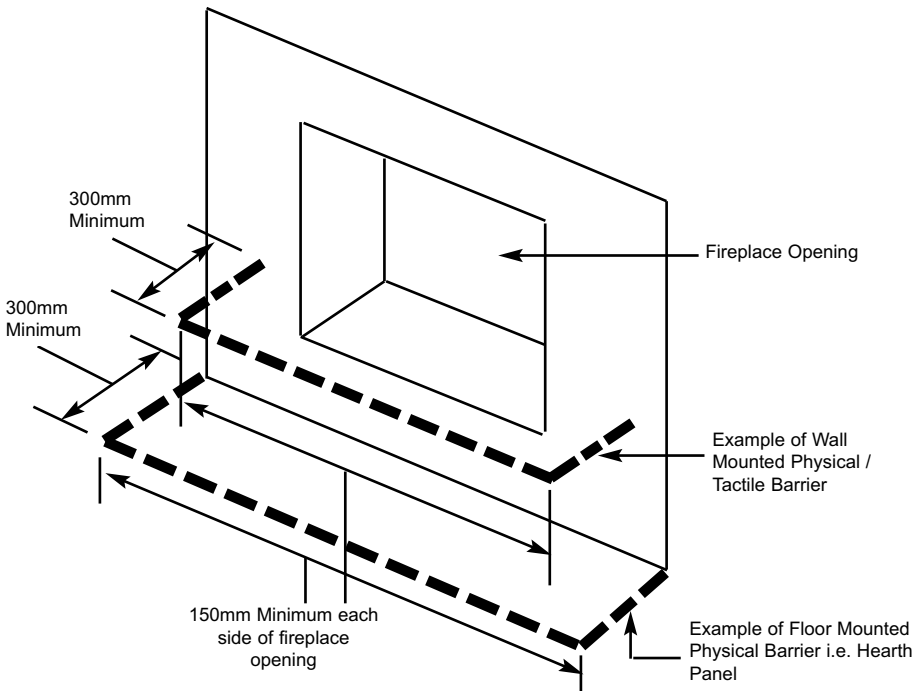

## SECTION 2 INSTALLATION OF FIRE

### 2.1 UNPACKING THE FIRE

Carefully lift the fire out of the carton. Remove the loose item packaging carefully from the front of the appliance. Check the contents as listed :-

#### Packing Check List

- 1 off Fire box / burner assembly
- 1 off Boxed ceramic base, front ceramic rail and 7 coals or 13 pebbles (4 off "FR" pebbles 7 off "L" large & 2 off "S" small pebbles)
- 1 off Loose items bag including remote handset and 5 off AA batteries on RC models.
- 1 off Flue restrictor baffle
- 1 off Installation & maintenance / user instruction book (combined)
- 1 off Trim & Fret (Kenilworth models only)
- 1 off Fascia (Diamond, Linear & Expression models only)

### 2.2 INSTALLING THE FIRE BOX

**Establish which type of flue you are intending to install the fire in to :-**

225 x 225mm (9 inch x 9 inch) brick built chimneys 175mm (7 inch) diameter lined brick or stone flue, insulated pre-fabricated metal flue box to BS 715 / BS EN 1856-2. When installing into 125mm (5 inch) diameter lined brick or stone flue, or insulated pre-fabricated metal flue box and liner to BS 715 / BS EN 1856-2 the restrictor baffle must not be fitted.

**The flue restrictor baffle (supplied in the loose items) should only be used in 225 x 225mm (9 inch x 9 inch) brick built chimneys where the flue pull is excessive. It must not be fitted if installing the product into a metal flue box, pre-cast or 125mm diameter lined flue. See figure 4 / 5 below for details on fitting / removing the restrictor baffle onto the spigot on the rear of the firebox.**



**Fig 4 - Flue Restrictor Baffle Not Fitted**

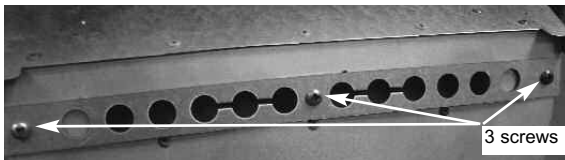

**Fig 5 - Flue Restrictor Baffle Fitted via 3 screws as shown**

**A spillage test must always be carried out to check satisfactory clearance of flue products, regardless of the type of flue the appliance is being fitted to.**

**For all models proceed as follows :-**

2.2.1 Remove the top glass retaining cover from the product. It is secured via the two screws as indicated. See figure 6 below.

**Fig. 6**

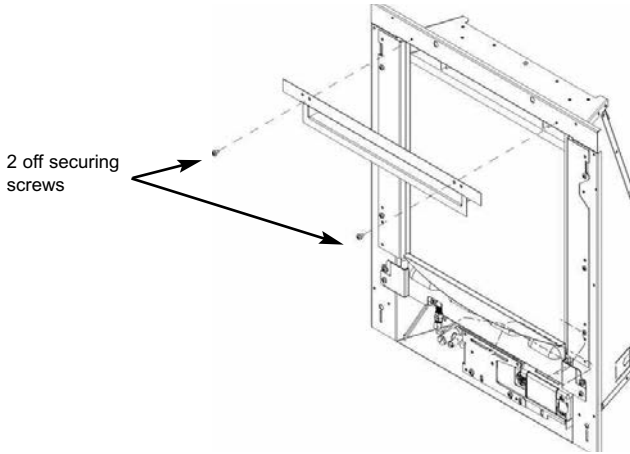

2.2.2 Remove the left and right hand side glass securing brackets from the product. They are secured via 3 off screws each side. See figure 7 below.

**Fig. 7**

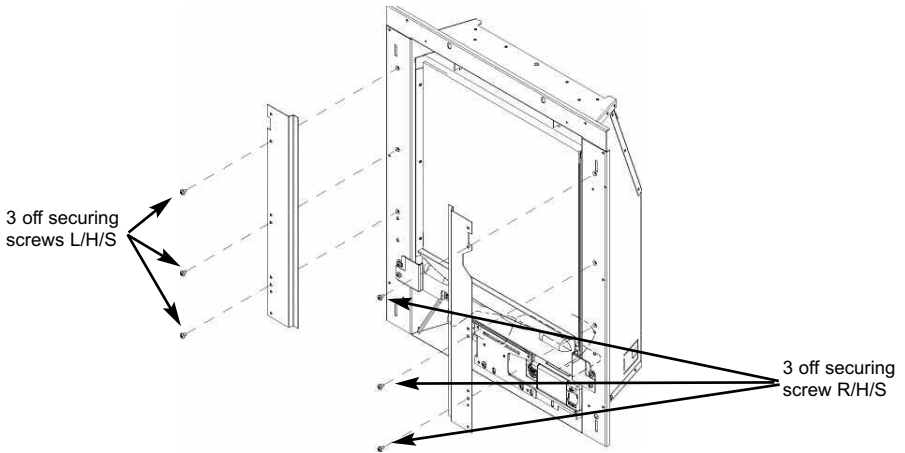

- 2.2.3 Lift the glass panel forwards and clear from the firebox, taking care not to damage the glass panel. See figure 8 below.

**Fig. 8**

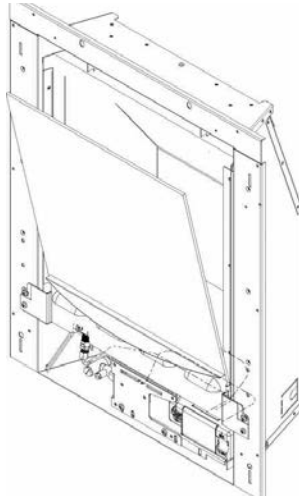

- 2.2.4 Remove the burner heat shield, which is retained by 2 off screws as shown below in figure 9.

**Fig. 9**

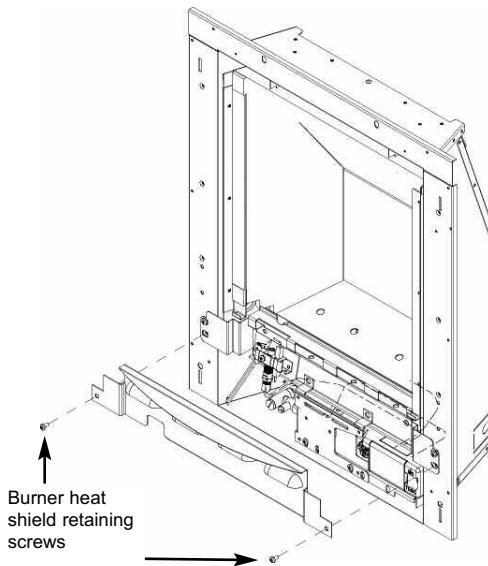

**For all Manual Control models proceed as follows :-**

- 2.2.5 Remove the two off screws from the left and right hand burner mounting brackets, plus the two screws from the base of the control panel as shown below in figure 10, this will allow removal of the complete burner unit from the firebox.

**Fig. 10**

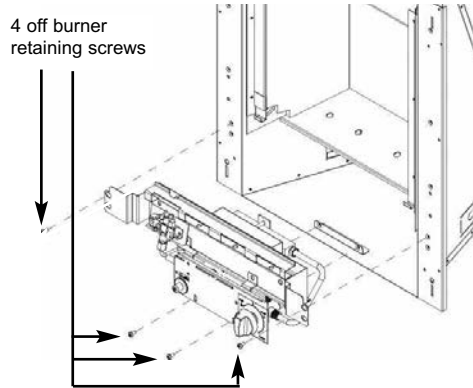

**For all Remote Control models proceed as follows :-**

- 2.2.6 Remove the two off screws from the left and right hand burner mounting brackets, plus the two screws from the base of the control panel as shown below in figure 11, this will allow removal of the complete burner unit from the firebox.

**Fig. 11**

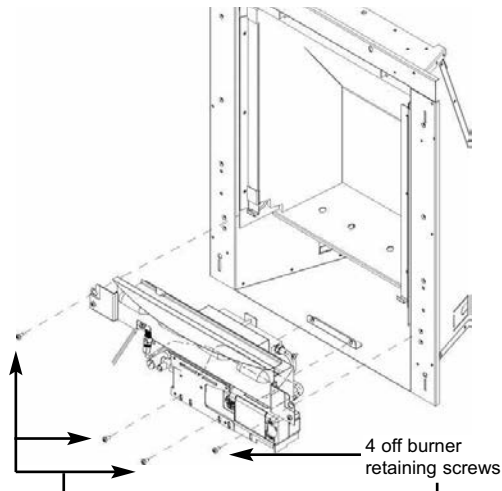

**For all Slide Control models proceed as follows :-**

- 2.2.7 Remove the burner. To allow burner removal, the control lever operating cable must be removed. The control lever operating cable can be seen running across the base of the fire, below the burner. To release the cable, unscrew the cable securing screw located in the centre of the aluminium operating arm and pull the cable out from its fixing hole. Release the other end of the cable by pushing the cable forwards to the right, i.e. into the operating arm so as to release the tension. Pull the cable nipple out of the retaining hole and remove the cable through the slot in the operating arm. See figure 12 below.

**Fig. 12**

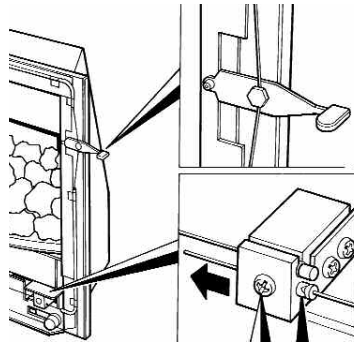

- 2.2.8 Remove the two off screws from the left and right hand burner mounting brackets, plus the two screws from the base of the control panel as shown below in figure 13, this will allow removal of the complete burner unit from the firebox.

**Fig. 13**

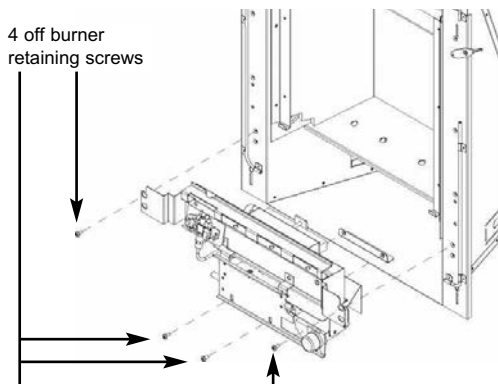

**Continue for all models as follows :-**

2.2.9 Whilst the fire box is still in position, decide which side the gas supply is to enter the fire from. If concealed pipe work is required plan the pipe run to enter the fire box through one of the openings in the sides or rear of the fire box below the fuelbed support panel and connect to the isolating / inlet elbow. The gas connection to the appliance should be made to the isolating / inlet elbow using 8mm rigid tubing. There must be no soldered joints within the firebox. See figure 14 & 15 below for suggested concealed pipe layouts.

**Fig. 14**

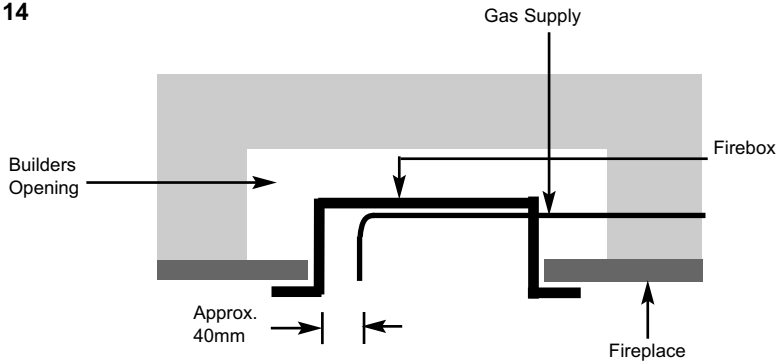

**Fig. 15**

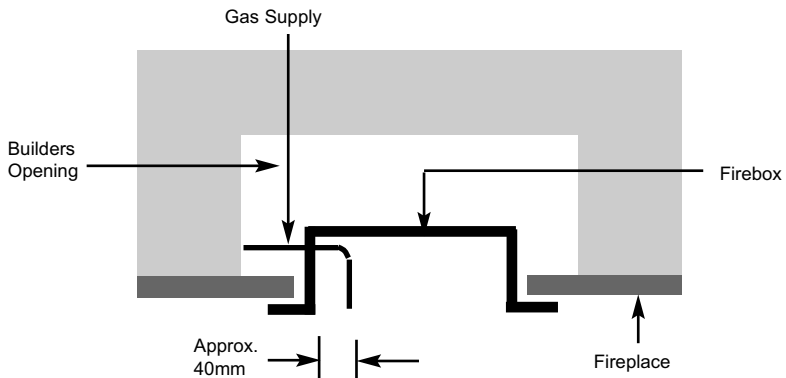

**Note :** Before breaking into the gas supply a pressure drop test should be carried out to establish that the existing pipework is sound.

Carefully withdraw the fire box from the opening to enable the gas supply and fire fixing to be completed.



**IMPORTANT : Sealing of the Gas Unused Gas Pipe Inlet Apertures**

In line with current regulations, **it is imperative that the gas supply inlet apertures that are not utilised during the installation are sealed with the foil tape as supplied.** Failure to seal these inlet apertures could lead to flame reversal, which in turn will damage the burner and control systems of the product. figure 16 below shows a correctly sealed installation.

**Fig. 16**



***PLEASE NOTE :-***

**BFM EUROPE LTD. WILL NOT BE LIABLE FOR  
GUARANTEE CLAIMS THAT ARE AS A DIRECT  
RESULT OF THE UNUSED GAS INLET APERTURES  
NOT BEING CORRECTLY SEALED.**

**The preferred method of fixing which is suitable for almost all situations is the cable fixing method which is described in the following section in detail.**

To fit using the **preferred** cable method proceed as follows-

2.2.10 Mark out and drill 4 off No 14 (6mm) holes in the back face of the fire opening in the positions shown below in figure 17.

**Fig. 17**

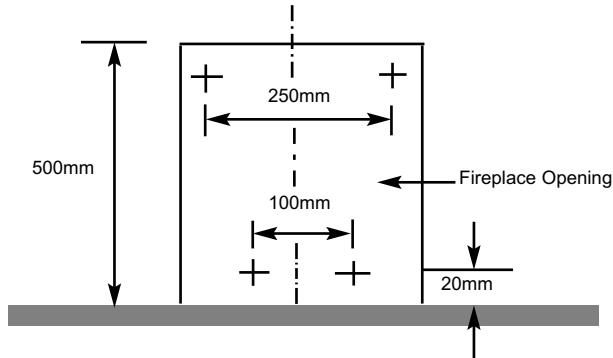

Fit the wallplugs provided and screw the fixing eyes securely into the rear of the fire opening. If the clearance at the rear of the fire is at the minimum specified for a precast flue application, it may be necessary to bend over the lower fixing eyes after screwing them fully in to the rear of a pre-cast starter block.

2.2.11 Uncoil the two fire fixing cables and thread one end of each of the cables through one of the two holes on each side of the flue outlet shroud.

2.2.12 Position the fire carefully on the (protected) surface of the hearth and reach into the fire opening. Thread each of the cables vertically downwards through the pair of fixing eyes on the same side of the fire. Thread the free end of the cables through the corresponding circular hole on each side of the lower rear of the fire. Carefully slide the fire box back into the fire opening and pull both cables tight.

2.2.13 Thread a tensioning screw over each of the cables and ensure that the tensioning nut is screwed fully up against the hexagon shoulder of the tensioning screw (this provides maximum travel for the tensioning nut).

2.2.14 Fit a screwed nipple on to each of the cables and pull hand tight up against the tensioning screw, then secure each nipple with a flat bladed screwdriver. See figure 18 overpage.

Fig. 18

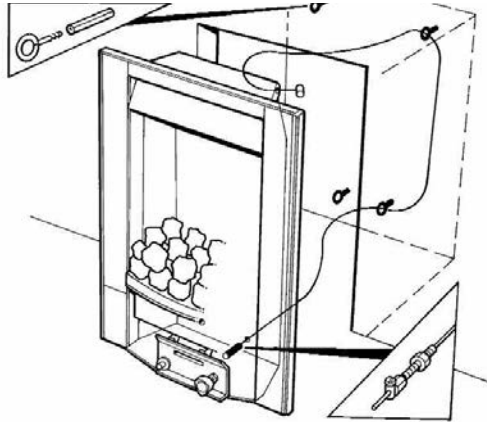

- 2.2.15 Evenly tighten the tensioning nuts to tension both cables and pull the fire snugly against the wall. Do not overtighten, it is only necessary to pull the seal up against the sealing face of the wall, it does not need to be compressed. Check that there are no gaps behind the seal.
- 2.2.16 With the fire securely in place, if a concealed gas connection has been made through either of the access holes in the sides of the fire, the holes should be closed around the pipe to prevent leakage of air through the gap around the pipe.
- 2.2.17 Refit the burner. Fit the four retaining screws on manual control models or two screws on remote control models and check that the burner is correctly locked into position.
- 2.2.18 Refit the front burner heat shield to the sides of the fire box (2 Screws) and secure the trim to the fire using the magnets provided.
- 2.2.19 **Before making the final gas connection, thoroughly purge the gas supply pipework to remove all foreign matter, otherwise serious damage may be caused to the gas control valve on the fire.**

The other firebox fixing method is as follows :-

In installations where the cable method is not suitable (e.g. loose masonry in rear of fire opening) the firebox can be secured to the fire surround using four screws and wall plugs provided. Below (figure 19) is a diagram to indicate the hole centre positions available on the firebox to facilitate the screw fixing to the fireplace / surround.

**Fig. 19**

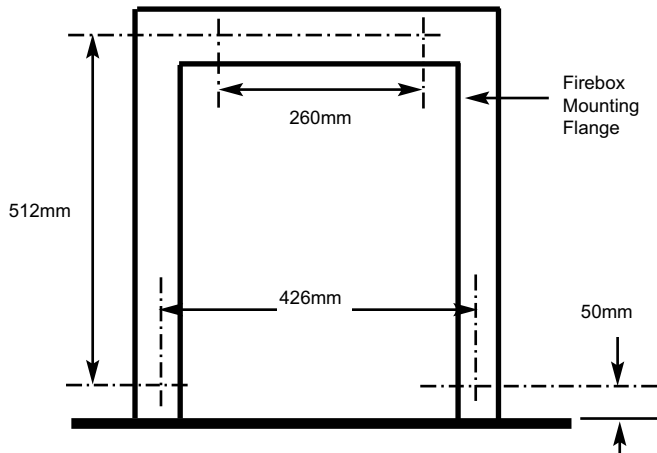

### **2.3 GAS TIGHTNESS AND INLET PRESSURE (MANUAL CONTROL MODELS)**

- 2.3.1 Remove the pressure test point screw from the inlet elbow and fit a manometer.
- 2.3.2 Turn on the main gas supply and carry out a gas tightness test.
- 2.3.3 Depress the control knob and turn anti-clockwise to the position marked pilot. Hold in the control knob for a few seconds to purge the pipe work then press the igniter button. The burner should light, continue to hold the control knob for a few seconds then turn to the full-on position.
- 2.3.4 Check that the gas pressure for Natural Gas (G20) models is **20.0 mbar (+/- 1.0mbar) 8.0 in w.g.(+/- 0.4 in w.g.)** or for Propane Gas (G31) models **37.0 mbar (+/- 1.0mbar) 14.4 in w.g.(+/- 0.4 in w.g.)**
- 2.3.5 Turn off the fire, remove the manometer and refit the pressure test point screw. Check the pressure test point screw for gas tightness with the appliance turned on using a suitable leak detection fluid or detector.

## **2.4 GAS TIGHTNESS AND INLET PRESSURE (SLIDE CONTROL MODELS).**

- 2.4.1 Remove the pressure test point screw from the pressure test point and fit a manometer.
- 2.4.2 Turn on the main gas supply and carry out a gas tightness test.
- 2.4.3 Depress the control lever to the position marked pilot. Hold down the control lever for a few seconds to purge the pipe work. The burner should light, continue to hold the control lever for a few seconds to latch the valve then lift to the full-on position.
- 2.4.4 Check that the gas pressure for Natural Gas (G20) models is **20.0 mbar (+/- 1.0mbar) 8.0 in w.g.(+/- 0.4 in w.g.)**
- 2.4.5 Turn off the fire, remove the manometer and refit the pressure test point screw. Check the pressure test point screw for gas tightness with the appliance turned on using a suitable leak detection fluid or detector.

## **2.5 GAS TIGHTNESS AND INLET PRESSURE (REMOTE CONTROL MODELS).**

- 2.5.1 Remove the pressure test point screw from the inlet elbow and fit a manometer.
- 2.5.2 Turn on the main gas supply and carry out a gas tightness test.
- 2.5.3 Depress both the round buttons on the handset. The fire will then commence its ignition sequence and will light to high. See page 32-45 for full details of the operating method for the fire.
- 2.5.4 Check that the gas pressure is **20.0 mbar (+/- 1.0mbar) 8.0 in w.g.(+/- 0.4 in w.g.)**
- 2.5.5 Turn off the fire, remove the manometer and refit the pressure test point screw. Check the pressure test point screw for gas tightness with the appliance turned on using a suitable leak detection fluid or detector.

### SECTION 3 ASSEMBLING FUEL BED AND COMMISSIONING

#### 3.1 ASSEMBLING THE CERAMICS AND FUEL BED - COAL MODELS

- 3.1.1 Place the ribbed ceramic fuelbed base on top of the fuelbed support and pull fully forwards to the burner. **Make sure that the fuelbed base is located centrally in the fire box. Ensure that the fuelbed base fit fully down onto the fuel bed support and is not lodged on the burner. Ensure the air ports as indicated by the arrows are not blocked by the fuel-bed matrix.** See figure 20 & 21 below.

Fig. 20

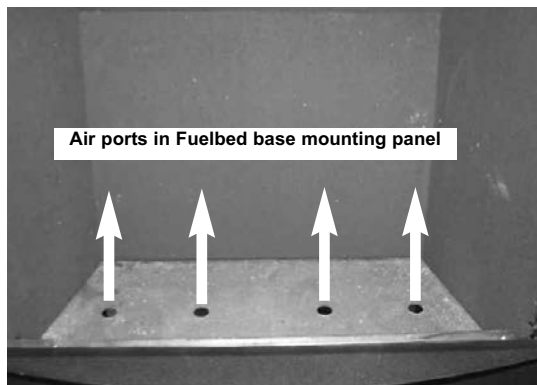
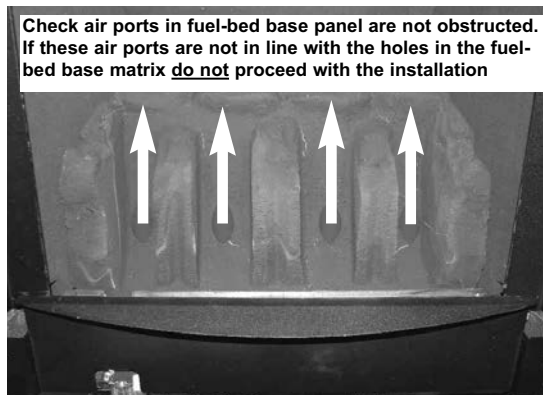

Fig. 21



**NOTE :** The position of the fuel-bed components are critical to the performance of the product. Therefore please ensure that the fuel-bed components are positioned as described in the following section prior to requesting a service call due to soot build up, poor flame pattern etc.

3.1.2 Position the front ceramic coal support onto the burner support as shown below in figure 22.

**Fig. 22**

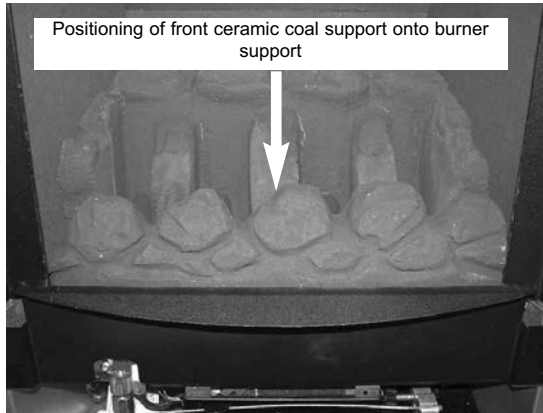

3.1.3 Fit the front row left hand coal as shown below in figure 23.

**Fig. 23**

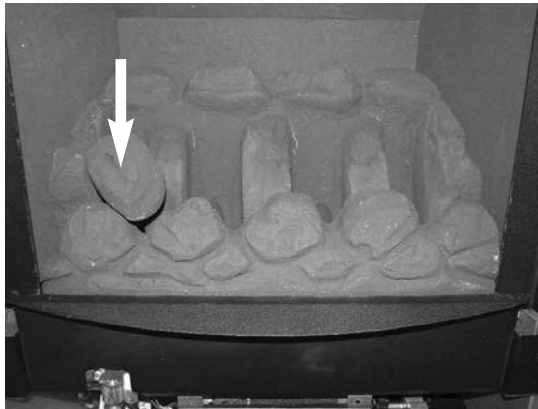

3.1.4 Fit the front row left hand side central coal as shown below in figure 24.

**Fig. 24**

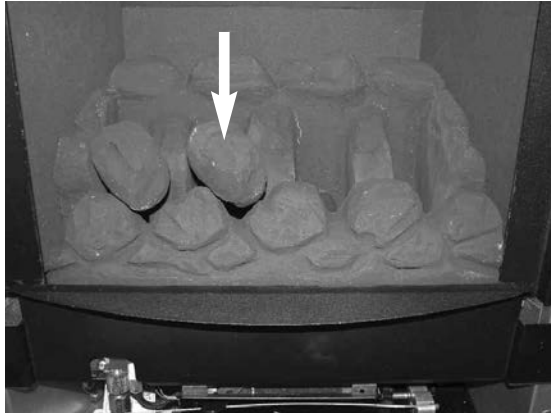

3.1.5 Fit the front row right hand side central coal as shown below in figure 25.

**Fig. 25**

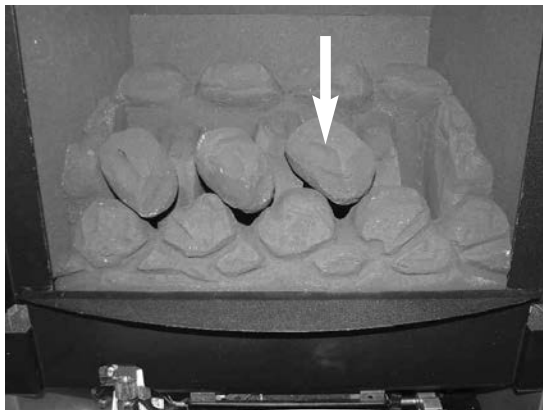



3.1.6 Fit the front row right hand coal as shown below in figure 26.

**Fig. 26**

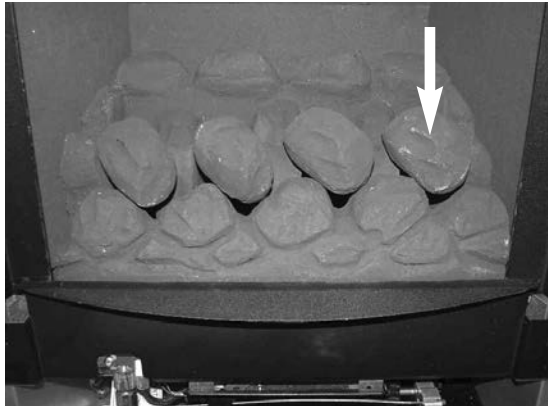

3.1.7 Fit the rear row of 3 coals as shown below in figure 27.

**Fig. 27**

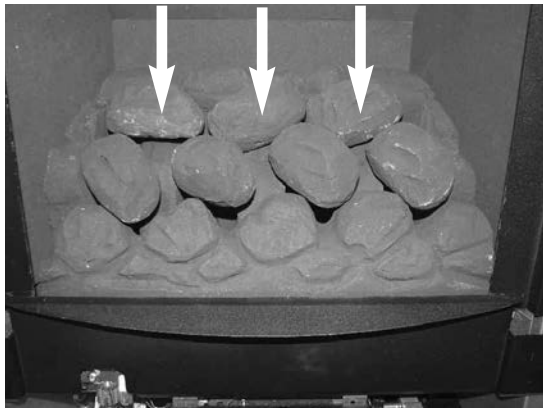

The exact position and fit of the coals may be very finely adjusted to give the most pleasing and random appearance.

**Warning : Use only the coals supplied with the fire. When replacing the coals remove the old coals and discard them. Fit a complete set of coals of the correct type. Do not fit additional coals or any coals other than a genuine replacement set.**

**To ensure that the release of fibres from these R.C.F (Refractory Ceramic Fibre) articles is kept to a minimum, during installation and servicing we recommend that you use a HEPA filtered vacuum to remove any dust accumulated in and around the appliance before and after working on the appliance. When replacing these articles we recommend that the replaced items are not broken up, but are sealed within heavy duty polythene bags, clearly labelled as “RCF waste”. RCF waste is classed as a “stable”, non reactive hazardous waste and may be disposed of at a landfill licensed to accept such waste Protective clothing is not required when handling these articles, but we recommend you follow the normal hygiene rules of not smoking, eating or drinking in the work area, and always wash your hands before eating or drinking.**

3.1.8            Replace the glass panel and retaining trims as described on pages 11 & 12

**NEVER USE THE FIRE WITHOUT THE GLASS PANEL IN POSITION, OR IF BROKEN OR CRACKED.**

## 3.2 ASSEMBLING THE CERAMICS AND FUEL BED - PEBBLE MODELS

- 3.2.1 Place the ribbed ceramic fuelbed base on top of the fuelbed support and pull fully forwards to the burner. **Make sure that the fuelbed base is located centrally in the fire box. Ensure that the fuelbed base fit fully down onto the fuel bed support and is not lodged on the burner. Ensure the air ports as indicated by the arrows are not blocked by the fuel-bed matrix.** See figure 28 & 29 below.

Fig. 28

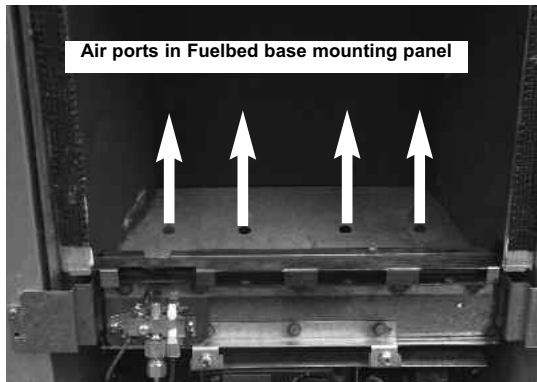
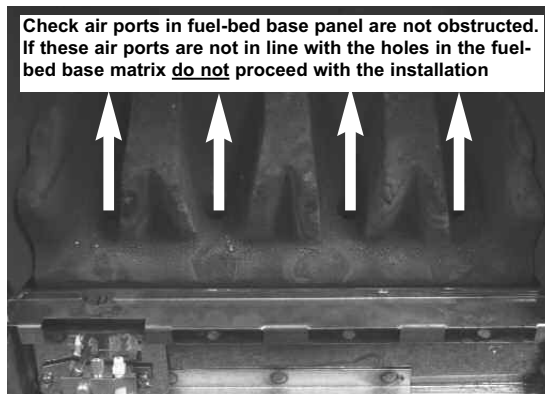

Fig. 29



**NOTE :** The position of the fuel-bed components are critical to the performance of the product. Therefore please ensure that the fuel-bed components are positioned as described in the following section prior to requesting a service call due to soot build up, poor flame pattern etc.

3.2.1 Position the front ceramic pebble support onto the burner support as shown below in figure 30.

**Fig. 30**

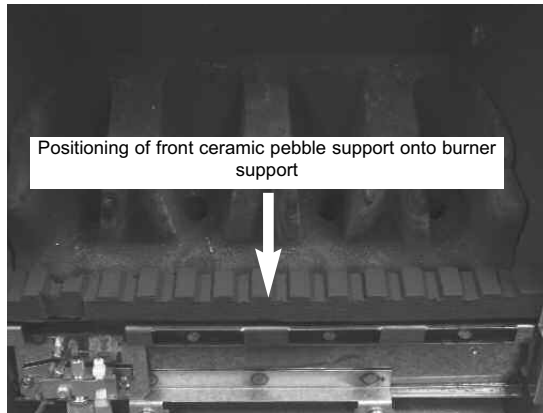

3.2.2 Fit four of the specially shaped pebbles as shown below in figure 31. Ensure that the cut-out in the rear face of the pebbles is positioned as indicated. The 4 off specially shaped pebbles are packed in a bag with a label "FR" on them.

**Fig. 31**

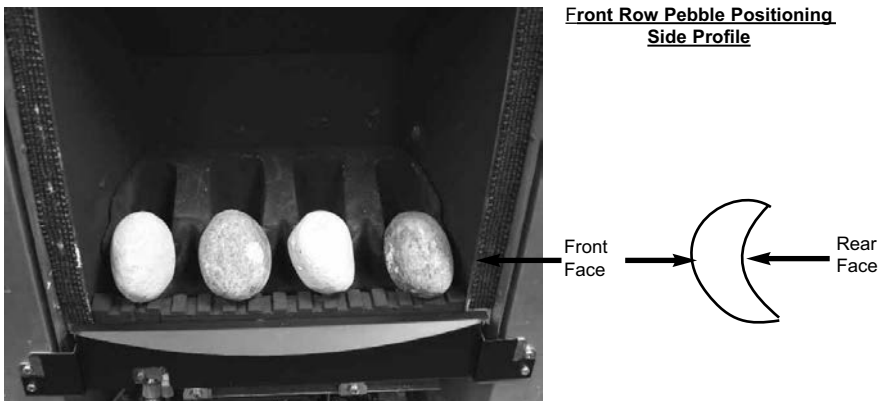

3.2.3 Select three of the large pebbles and position on the three central ribs in the fuelbed as indicated in figure 32 below.

**Fig. 32**

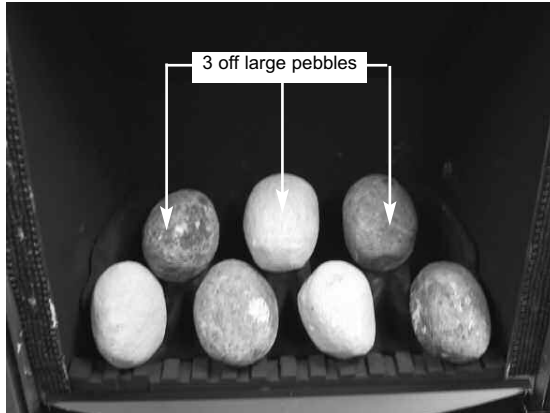

3.2.4 Select the two small pebbles and arrange along the second row of the fuelbed. (See figure 33 below).

**Fig. 33**

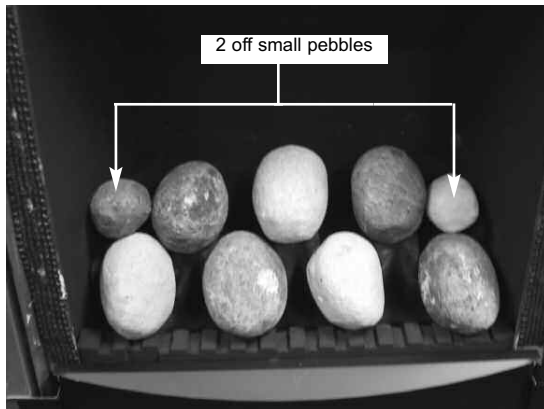

3.2.5 Select the four remaining large pebbles and position as shown along the rear of the fuel-bed base in figure 34 below.

**Fig. 34**

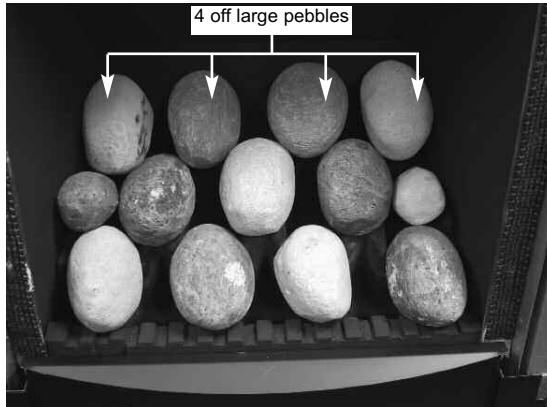

3.2.6 Do a final check that the pebbles are layed out as shown below in figure 35.

**Fig. 35**

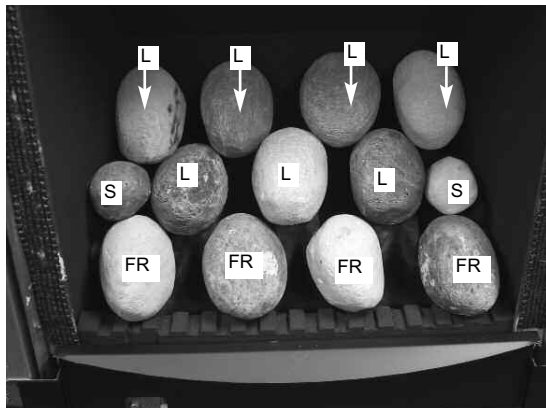

The exact position and fit of the pebbles may be very finely adjusted to give the most pleasing and random appearance.

**Warning : Use only the pebbles supplied with the fire. When replacing the pebbles remove the old pebbles and discard them. Fit a complete set of pebbles of the correct type. Do not fit additional pebbles or any pebbles other than a genuine replacement set.**

**To ensure that the release of fibres from these R.C.F (Refractory Ceramic Fibre) articles is kept to a minimum, during installation and servicing we recommend that you use a HEPA filtered vacuum to remove any dust accumulated in and around the appliance before and after working on the appliance. When replacing these articles we recommend that the replaced items are not broken up, but are sealed within heavy duty polythene bags, clearly labelled as “RCF waste”. RCF waste is classed as a “stable”, non reactive hazardous waste and may be disposed of at a landfill licensed to accept such waste Protective clothing is not required when handling these articles, but we recommend you follow the normal hygiene rules of not smoking, eating or drinking in the work area, and always wash your hands before eating or drinking.**

3.2.7 Replace the glass panel and retaining trims as described on pages 11 & 12.

**NEVER USE THE FIRE WITHOUT THE GLASS PANEL IN POSITION, OR IF BROKEN OR CRACKED.**

### **3.3 LIGHTING THE APPLIANCE (MANUAL CONTROL MODELS)**

3.3.1 Turn on the gas isolation tap.

3.3.2 Depress the control knob and turn anti-clockwise to the position marked pilot. Hold in the control knob for a few seconds to purge the pipe work.

3.3.3 Continue to hold-in the control knob and press the igniter button. If the burner does not light, continue to press the igniter button until ignition occurs. Continue to hold the control knob for 5-10 seconds to allow the thermocouple to heat up, if the pilot goes out when the control knob is released, repeat the lighting sequence.

3.3.4 Turn the control knob in the anti-clockwise direction to the high position and the main burner will light. Keep the control knob in the high position for approximately. 10 mins until the fire has warmed up, then adjust as necessary.

3.3.5 Turn the control knob clockwise to the low position and the gas input will be reduced to the minimum setting.

- 3.3.6 Slightly depress the control knob and turn to the pilot position, the main burner will go out but the pilot will remain lit.
- 3.3.7 Slightly depress the control knob and turn to the off position, the pilot will now be extinguished.

**WARNING : If the fire goes out for any reason or is turned off and it is necessary to re-light the fire it is important to allow the fire to cool for 3 minutes before attempting to re-light it.**

#### **3.4 LIGHTING THE APPLIANCE (SLIDE CONTROL MODELS)**

- 3.4.1 Turn on the isolation valve. Depress the control lever fully downwards to the position marked " Z". Hold down the control lever for a few seconds to allow the gas to reach the pilot.
- 3.4.2 The fire will then begin its ignition sequence. If the pilot does not light, continue to press the control lever until ignition occurs. The pilot flame can be seen by looking underneath the front ceramic rail, above the burner heat shield, at the front left hand side of the fuel. When the pilot has lit, continue to hold the control lever down for 5-10 seconds to allow the thermocouple to heat up, before releasing the lever apply one firm downwards push to ensure that the f.s.d. valve is fully latched, if the pilot goes out when the control lever is released, repeat the lighting sequence.
- 3.4.3 After lighting, move control lever up to the high position and the main burner will light. It is recommended that for the most efficient performance the fire is allowed to warm up for a few minutes with the control lever set to high.
- 3.4.4 The gas control can be moved from the High to Low position to give the desired heat output.
- 3.4.5 To turn the fire off, FULLY raise the control lever to the OFF position.

**WARNING : If the fire goes out for any reason or is turned off and it is necessary to re-light the fire it is important to allow the fire to cool for 3 minutes before attempting to re-light it.**



### 3.5 FITTING THE BATTERIES - REMOTE CONTROL MODELS

3.5.1 The control valve is located at the base of the fire as shown below in figure 36.

**Fig. 36**

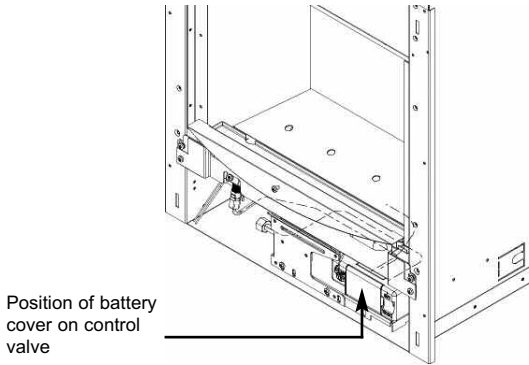

3.5.2 Remove the battery compartment cover from the control valve as indicated below in figure 37 and fit the 3 off AA sized alkaline batteries supplied to the control valve unit.

3.5.3 Ensure that the power isolation switch is in position "1" and the power indicator light is illuminated (red) after the batteries have been fitted as shown in figure 37 below.

**Fig. 37**

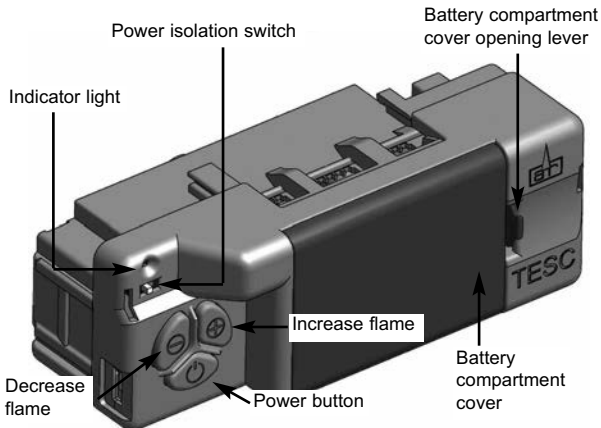

**IMPORTANT NOTE : THE BATTERIES SHOULD BE REPLACED WITH GOOD QUALITY ALKALINE BATTERIES WHEN REQUIRED, THE BATTERY LIFE IS EXPECTED TO BE A MINIMUM OF 12 MONTHS WITH NORMAL USAGE. FOR BEST PERFORMANCE BFM EUROPE RECOMMEND THE USE OF ENERGIZER BATTERIES WITH IT'S PRODUCTS.**

3.5.4 For Remote control model operation please see section 3.8

### 3.6 LIGHTING THE FIRE MANUALLY VIA THE CONTROL VALVE

3.6.1 These products can be operated manually by using the buttons directly on the fire control in addition to the handset (should the need arise).

3.6.2 To operate the fire press and hold the “power” button as shown below in figure 38 for two seconds, release as soon as the red indicator light shown in figure 38 illuminates. The burner will then start its ignition sequence and light to the maximum heat input level. **For most efficient performance leave the fire on high when lighting from cold for ten minutes.**

Fig. 38

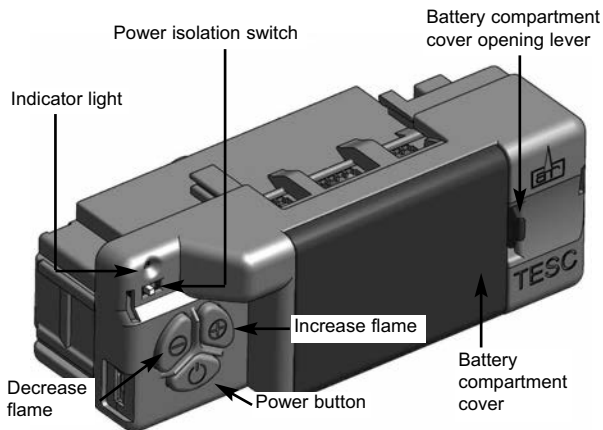

3.6.3 To reduce the heat input, press and release the (-) button to lower the heat input level one step at a time. Pressing the (-) button continuously will move the heat input level to the minimum.

3.6.4 To increase the heat input level, press then release the (+) button to increase the heat input level one step at a time. Pressing the (+) button continuously will move the heat input level to the maximum.

3.6.5 To turn the fire off, press the power button and the burner will stop.

3.6.6 **If you are not intending to use the fire for a long period (i.e. over the summer months) the battery life can be extended by sliding the power isolator switch to the left (to the “0” position away from the “1” position) on the valve itself, which is located behind the ashpan cover on the fire.**

### 3.7 SETTING THE TIME, DATE & TEMPERATURE ON THE REMOTE HANDSET

- 3.7.1 Fit the 2 off AA batteries to the handset by removing the cover on the rear of the handset and inserting the batteries, ensure the correct +/- polarity is observed. Following insertion of the batteries the screen displayed will be as shown below in figure 39.

**Fig. 39**



- 3.7.2 Hold the handset with one hand ensuring your hand is wrapped around the back and that your hand is in contact with both sides of the handset. The green light of the “unlock” symbol should light and the screen displayed will be as shown overpage in figure 40.
- 3.7.3 The “H” symbol as indicated in figure 40 overpage indicates that the timer can now be set in either 24hr or 12hr mode. Press the + or - buttons on the handset to toggle between the two settings, figure 40 overpage displays the 24hr mode.

**Fig. 40**



3.7.4 When the 24hr or 12hr time display option has been chosen and you are ready to confirm the setting you want press the SET button on the handset to progress to setting the day of the week as shown overpage in figure 41.

3.7.5 Press and release the + and - buttons on the handset until the correct day of the week is shown on the handset display

Mo = Monday  
Tu = Tuesday  
We = Wednesday  
Th = Thursday  
Fr = Friday  
Sa = Saturday  
Su = Sunday

3.7.6 Press SET to accept the day of the week and progress to setting the hour of the day.

**Fig. 41**



3.7.7 As shown above in figure 41 the time on the handset can now be set by using the + and - buttons to change the hour to the correct hour then press SET to store and to move to setting the minute. Repeat this process for setting the minute to the correct minute then press SET to store.

3.7.8 The handset will then display the temperature setting screen as shown overpage in figure 42, the option to choose either Celsius or Fahrenheit can be chosen, these settings are shown as either C or F. Use the + and - buttons to toggle between these two options then press SET to store. The important settings have now been completed so press and hold the SET button for a few seconds and this will exit the set-up menu.

Fig. 42



3.7.9 The control is now ready for use with the burner.

3.7.10 If the handset is misplaced you can “page it” by pressing the (+) button only on the control valve on the fire for a period of 5 seconds. The handset will flash and make an audible noise to help you locate it. Once you find the handset with one hand ensure your hand is wrapped around the back and that your hand is in contact with both sides of the handset then the audible noise will cease. The flashing and sound will last for 60 seconds each time the handset is paged as described. If not found in 60 seconds page the handset again until located.

### 3.8 LIGHTING THE FIRE - REMOTE CONTROL MODELS

3.8.1 Ensure valve power isolation switch is in the on position - see figure 37 and that the time, date & temperature display settings as shown in section 3.7 have been completed. Hold the handset with one hand ensuring your hand is wrapped around the back and that your hand is in contact with both sides of the handset. The green light of the “unlock” symbol should be lit. See figure 43 below.

**Fig. 43**



3.8.2 Press and hold the power button continuously until the word “PILOT” appears at the bottom left of the display as shown overpage in figure 44, (this typically takes two seconds). The burner will now light at maximum heat input level and will display “MAX” in the bottom left hand side of the display as shown in figure 44 overpage.

NOTE : If the power button is pressed for too long or too short a time or the grip on the handset is not firm or is released too soon, the lighting sequence will be interrupted and not complete. The reason for the remote control having this strict start sequence is for safety reasons so that the starting operation of the fire will be most unlikely to be done other than intentionally by an adult.

**Fig. 44 - "PILOT" displayed**



"PILOT" displayed on handset during ignition sequence (typically takes two seconds)

**Fig. 45 - "MAX" & large flame symbol displayed**



"MAX FLAME" displayed on handset when burner is lit to maximum rate



### 3.8 LIGHTING THE APPLIANCE - REMOTE CONTROL MODELS (CONTINUED)

3.8.3 To decrease the heat input level of the burner hold the handset as described in section 3.8.1 to unlock the keypad then press and release the - button. Pressing and releasing the - button will lower the heat input level one step at a time. Pressing the - button continuously will move the heat input level to the minimum, see figure 46 below.

**Fig. 46**

"MIN FLAME"  
displayed on  
handset when  
burner is  
reduced to  
minimum rate



3.8.4 To increase the heat input level of the fire's burner hold the handset as described in section 3.8.1 to unlock the keypad then press and release the + button. Pressing and releasing the + button will increase the heat input level one step at a time. Pressing the + button continuously will move the heat input level to the maximum.

3.8.5 To turn the fire off hold the handset as described in section 3.8.1 to unlock the keypad then press and release the power button. The burner will go out.

### 3.8.6

**If you are not intending to use the fire for a long period (i.e. over the summer months) the battery life can be extended by sliding the power isolator switch to the left (to the “0” position away from the “1” position) on the valve itself, which is located behind the ashpan cover on the fire.**

### 3.8.7

**In the event of loss of the remote handset, as a backup the fire can be controlled from the valve, which is located behind the ashpan cover on the fire, see section 3.6 for full manual operating instructions. If your fire does not operate manually please consult the troubleshooting chart on the rear page of this manual.**

### 3.8.8

If the handset is misplaced you can “page it” by pressing the (+) button only on the control valve on the fire for a period of 5 seconds. The handset will flash and make an audible noise to help you locate it. Once you find the handset with one hand ensure your hand is wrapped around the back and that your hand is in contact with both sides of the handset then the audible noise will cease. The flashing and sound will last for 60 seconds each time the handset is paged as described. If not found in 60 seconds page the handset again until located.

## 3.9

### **ADVANCED SETTINGS MENU OF THE REMOTE CONTROL**

#### 3.9.1

##### **Snooze mode in manual operation**

##### 3.9.1.1

Snooze mode is a time period which can be set which will turn the fire automatically off after a certain time period has elapsed.

##### 3.9.1.2

Hold the handset with one hand ensuring your hand is wrapped around the back and that your hand is in contact with both sides of the handset. The green light of the “unlock” symbol should light. The snooze time period can be set either before or during manual operation of the fire.

##### 3.9.1.3

With the handset held as described above, press the mode button to scroll through the functions until the symbols MAN and Zzz are flashing at the top of the display as shown overpage in figure 47.

##### 3.9.1.4

Press and release the set button and this will put the control into the manual snooze mode.

##### 3.9.1.5

The default time period in snooze mode is 1:00 hour.

**Fig. 47**



- 3.9.1.6 Pressing the set button again will now show you the snooze time period remaining. The snooze time period can be adjusted by pressing the + or - buttons on the handset. This time period can be set ranging from 1 minute to 4:00 hours.
- 3.9.1.7 To adjust the snooze period, hold the handset with one hand ensuring your hand is wrapped around the back and that your hand is in contact with both sides of the handset. The green light of the “unlock” symbol should light. Press the set button and the screen will show how long is left of the snooze period as shown overpage in figure 48.

**Fig. 47**



- 3.9.1.8 To adjust the snooze period use the + and - buttons to increase or decrease the snooze period for any period between 1 minute and 4:00 hours.
- 3.9.1.9 When the correct snooze period is indicated on the handset, press the set button to store the required time period, or alternatively the handset can be left for a few seconds and the period will be stored automatically.
- 3.9.1.10 When the countdown timer for the snooze period has reached zero the fire will turn off (as if you had turned the fire off manually).

### 3.9.2 Thermostatic mode

**PLEASE NOTE : Thermostatic mode of this fire will only allow regulation of the room temperature by the fire when it has been already lit via manual operation of the handset. It will not allow the fire to light automatically due to low ambient room temperature and should therefore not be relied upon for frost protection purposes.**

3.9.2.1 Hold the handset with one hand ensuring your hand is wrapped around the back and that your hand is in contact with both sides of the handset. The green light of the “unlock” symbol should light.

3.9.2.2 With the handset held as described above, press and release the mode button several times as necessary until the display has the thermometer symbol flashing at the top of the display. Press the set button to enter this mode, as shown below in figure 48.

Fig. 48



3.9.2.3 Press the set button again to see the temperature setting that is set (the default is 24 degrees celsius). If a different set temperature is required, whilst the display is showing this set temperature, press the + and - buttons to alter this setting, press the set button to store the required temperature, or alternatively the handset can be left for a few seconds and the temperature will be stored automatically.

3.9.2.4 If at any time the power button is operated during thermostat mode the control will cancel any thermostat operation and return the control to manual mode.

3.9.2.5 **IMPORTANT NOTE : Thermostat mode will not light the fire automatically and will only regulate between the maximum and minimum burner setting. The fire must be lit manually via the handset and then you enter thermostat mode as described in this section and set the temperature. When no longer requiring thermostat mode turn off the burner and the handset will return to manual mode.**

### **3.10 FITTING THE TRIMS & FRETS OR FASCIA'S**

#### **Models supplied with one piece trim & fret / ashpan cover (Kenilworth models)**

3.10.1 Fit the outer trim assembly to the firebox with the magnets provided.

3.10.2 Remove the fret & ashpan cover from the packaging. Place fret up to the front radiused burner heat shield .

3.10.3 Place ashpan cover under fret assembly and centralise.

#### **Models supplied with fascia's (Linear models)**

3.10.4 Refer to the fitting instructions supplied with the fascia for advice on removal / re-fitting.

**NOTE :** Some models in this range are not supplied with a fret from the factory, therefore please consult your local retailer for fitting advice on the type of fret supplied with these models.

#### **Models supplied with one piece HITW fascia's (Diamond & Expression models)**

3.10.5 Hook the fascia onto the top mounting bracket fitted to the firebox.

3.10.6 The bottom of the fascia is retained by magnets fitted to the lower retaining brackets.

### 3.11 CHECKING FOR CLEARANCE OF COMBUSTION PRODUCTS

- 3.11.1 Close all doors and windows in the room.
- 3.11.2 Light the fire and allow to run for approximately 5 minutes on high position.
- 3.11.3 After approximately 5 minutes hold a smoke match just inside and below the centre of the lower front edge of the top of the fire as shown at the bottom of the page in figure 49 (It is recommended that a suitable smoke match holder is used when checking for clearance of combustion products). All smoke generated should be drawn back into the flue. If slight spillage occurs or if in doubt, repeat the test after a further 5-10 minutes. **If the test indicates that spillage is occurring and the flue restrictor baffle has been fitted, it should be removed and the test repeated after the fire has cooled.**
- 3.11.4 If spillage persists, the flue is not functioning correctly and a fault exists. If, after investigation the fault cannot be traced and rectified, the fire must be disconnected from the gas supply and expert advice obtained.
- 3.11.5 If there is an extractor fan fitted any where in the vicinity of the appliance, the spillage test should be repeated with the fan running on maximum and all interconnecting doors open.
- 3.11.6 After ensuring that the fire is safe to use it should be left on high position to fully warm up. During this time a slight odour may be noticed, this is due to the “newness” of the fire and will soon disappear.

Finally, hand the Installation and Maintenance Instructions and the Users Instructions over to the customer and explain the operation of the fire.

**Fig. 49**



Smoke Match Position -  
Approximately 10mm  
inside the centre of the  
draught diverter.

## SECTION 4 MAINTENANCE

### Servicing Notes

Servicing should be carried out annually by a competent person such as a registered engineer. **This is a condition of the Flavel Fires guarantee schemes.**

The service should include **changing the oxypilot as a condition of the guarantee** and visually checking the chimney and fire opening for accumulations of debris and a smoke test to check for a positive up-draught in the chimney.

The condition of the coals / pebbles should be checked and **if necessary the whole set should be replaced with a genuine replacement set.**

The burner assembly is designed to be removed as a complete unit for ease of access. **After any servicing work a gas tightness check must always be carried out.**

### Manual Control Fires – For Diagrams refer to Section 2

#### 4.1 Removing the burner assembly from the fire. (MC models)

4.1.1 Prepare work area (lay down dust sheets etc.)

4.1.2 Remove the trim. Lift the fender and ash pan cover out of the way and put them in a safe location. Remove the glass panel, unscrewing the top and side retaining brackets, see page 11 & 12 of this manual for information. Carefully lift clear the glass panel. Remove the coals or pebbles, front ceramic from the rail and fuel-bed base matrix. Unscrew the two pozi-drive fixing screws which secure the burner heat shield and remove it from the fire.

4.1.3 Isolate the gas supply and remove the inlet pipe from the appliance inlet elbow. Unscrew and remove the four screws which retain the burner. Remove the burner assembly from the fire.

4.1.4 To refit the burner assembly. Push the base of the control panel fully into the fire and secure with the four screws. Refit the gas supply pipe and carry out a gas tightness test. Refit the burner heat shield then refit the coals / pebbles referring to section 3 for the correct coal / pebble layout. Refit the glass panel and glass panel retaining trims. The fender and ash pan cover can now be re-positioned. Refit the trim.



## **4.2 Removing the Piezo Igniter (MC models)**

4.2.1 Remove the burner assembly as in section 4.1

4.2.2 Disconnect the ignition lead from the piezo and unscrew the retaining nut on the rear of the control panel. Withdraw the piezo from the front of the control panel. Reassemble in reverse order and carry out a gas tightness test. Refit the burner heat shield then refit the coals / pebbles referring to section 3 for the correct coal layout. Refit the glass panel and glass panel retaining trims. The fender and ash pan cover can now be re-positioned. Refit the trim.

## **4.3 Removing the Control Tap from the fire (MC models)**

4.3.1 Remove the burner assembly as in section 4.1.

4.3.2 Pull the control knob off the control tap spindle.

4.3.3 Loosen and remove the three gas pipe retaining nuts from the control tap and release the ends of the gas pipes from the control tap body. Loosen and remove the thermocouple securing nut from the end of the control tap.

4.3.4 Unscrew the control tap locknut from the front of the control panel and remove the control tap.

4.3.5 To refit a control tap, reassemble in reverse order noting that the control tap locates with a flat in the control panel. Carry out a gas tightness test after re-assembly. Refit the burner heat shield then refit the coals / pebbles referring to section 3 for the correct coal layout. Refit the glass panel and glass panel retaining trims. The fender and ash pan cover can now be re-positioned. Refit the trim.

## **4.4 Removing the Oxy-Pilot Assembly (MC models)**

**Note : Because this appliance is fitted with an atmosphere sensing ‘Oxy-Pilot’ it is not possible to replace the thermocouple separately, because the thermocouple position is factory set to a tight tolerance. Any replacement of parts on the pilot requires a complete new pilot assembly.**

4.4.1 Remove the burner assembly as in section 4.1

4.4.2 Unscrew and remove the thermocouple retaining nut from the end of the control tap and disconnect the ignition lead from the pilot electrode.

4.4.3 Unscrew and remove the two pozi-driv screws which secure the pilot assembly to the burner. Remove the pilot.

## **Slide Control Fires - For Diagrams refer to section 2**

### **4.5 Removal of the burner assembly (SC models)**

- 4.5.1 Prepare the work area (lay down dust sheets etc.)
- 4.5.2 Remove the trim. Lift the fender and ash pan cover out of the way and put them in a safe location. Remove the glass panel, unscrewing the top and side retaining brackets, see page 10 & 11 of this manual for information. Carefully lift clear the glass panel. Remove the coals / pebbles, front ceramic from the rail and fuel-bed base matrix. Remove all of the loose coals / pebbles and front ceramic rail. Unscrew the two pozi-drive fixing screws which secure the burner heat shield and remove it from the fire.
- 4.5.3 Isolate the gas supply and remove the inlet pipe from the appliance inlet elbow. To allow burner removal, the control lever operating cable must be removed. The control lever operating cable can be seen running across the base of the fire, below the burner. To release the cable, unscrew the cable securing screw located in the centre of the aluminium operating arm and pull the cable out from its fixing hole. Release the other end of the cable by pushing the cable towards the right i.e. into the operating arm so as to release the tension. Pull the cable nipple out of the retaining hole and remove the cable through the slot in the operating arm. Remove the two retaining screws at the base of the burner unit, and the screw each side of the burner unit. The base of the burner unit can now be pulled forward, allowing the burner to be removed outwards and downwards from the fire box. Remove the burner assembly from the fire.
- 4.5.4 Refit the burner assembly to the firebox by carefully pushing the bottom of the burner back into position. Secure using the two screws into the side frame of the firebox, and two screws into the base. It is now necessary to refit and correctly tension the operating cable. To do this, first set the control lever to the horizontal (central position), this is the position which creates maximum tension in the operating cable. Refit the operating cable to the aluminium operating arm, firstly locating the nipple on one end of the cable into recess in operating arm and then feed the other end through hole in operating arm. Pull the operating cable until it is finger tight and secure with screw into operating arm (do not over-tighten). Move the control lever fully downwards and check

that the left hand micro-switch operates the igniter and that the control valve spindle is fully depressed. Move the control lever upwards to the "off" position and check that the right hand (cut-off) micro-switch operates. Check that the control lever operates smoothly and safely. Refit the burner heat shield then refit the coals / pebbles referring to section 3 for the correct coal / pebble layout. Refit the glass panel and glass panel retaining trims. The fender and ash pan cover or fascia can now be re-positioned.

#### **4.6 Removal of the battery ignitor (SC models)**

4.6.1 Remove the burner assembly as described in section 4.5

4.6.2 Disconnect the ignition lead and 2 off microswitch leads from the igniter. Unscrew the Battery retaining cap and place battery to one side. Then unscrew igniter retaining ring and remove igniter from panel. Re-assemble in reverse order and carry out a gas tightness test. Refit the burner heat shield then refit the coals / pebbles referring to section 3 for the correct coal / pebble layout. Refit the glass panel and glass panel retaining trims. The fender and ash pan cover or fascia can now be re-positioned.

#### **4.7 Replacing the battery (SC models)**

4.7.1 Unscrew Battery retaining cap situated at the front right of the fire and remove the battery

4.7.2 Replace in the reverse order using a 1.5V AA Alkaline Battery.

#### **4.8 Removing the Oxy-Pilot Assembly (SC models)**

**Note: Because this appliance is fitted with an atmosphere sensing 'Oxy-Pilot' it is not possible to replace the thermocouple separately, because the thermocouple position is factory set to a tight tolerance. Any replacement of parts on the pilot requires a complete new pilot assembly.**

4.8.1 Remove the burner assembly as in section 4.5

4.8.2 Unscrew and remove the thermocouple retaining nut from the end of the control tap, disconnect the ignition lead from the pilot electrode and the two inline leads from the microswitch.

4.8.3 Unscrew and remove the two pozi-drive screws which secure the pilot assembly to the burner. Remove the pilot.

4.8.4 Re-assemble in reverse order and carry out a gas tightness test. Refit the burner heat shield then refit the coals / pebbles referring to section 3

correct layout.

- 4.8.4 (Cont.) Refit the glass panel and glass panel retaining trims. The fender and ash pan cover can now be re-positioned. Refit the trim.

## 4.9 Replacing the Control Cable (SC models)

- 4.9.1 The control lever operating cable can be seen running across the base of the fire, below the burner. To release the cable, unscrew the cable securing screw located in the centre of the aluminium operating arm and pull the cable out from its fixing hole. Release the other end of the cable by pushing the cable towards the right i.e. into the operating arm so as to release the tension. Pull the cable nipple out of the retaining hole and remove the cable through the slot in the operating arm. See figure 50 opposite.

**Fig. 50**

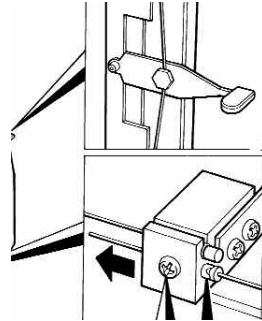

- 4.9.2 Hold the hexagonal control lever cable locking bush with a spanner and unscrew the locking screw using a 2mm allen key to release the cable from the control lever. The control cable can now be removed from the cable guide tubes.
- 4.9.3 To fit the replacement cable, thread the end of the new cable into the long length of p.t.f.e. sleeve (as supplied), taking care not to kink the sleeve. Now carefully feed the sleeve and cable into the left hand cable guide tube until the ends emerge above the control lever. Now thread the short length of p.t.f.e. sleeve over the end of the cable and thread the sleeve and cable into the top of the short cable guide tube.
- 4.9.4 When the end of the cable emerges from the short cable guide tube, locate the nipple on the other end of the cable into the locating hole in the aluminium operating arm. Thread the free end of the cable into the cable retaining hole on the operating arm, but at this stage do not tighten the securing screw.
- 4.9.5 Fit the hexagonal control lever cable locking bush onto the control lever and fit the control cable loosely into the bush in the gap between the two lengths of p.t.f.e. sleeve. Ensure that the cable is located in the retaining hole in the locking bush and tighten the screw sufficiently to retain the cable but still allowing it to slide for adjustment.

- 4.9.6 It is now necessary to correctly tension the operating cable. To do this, first set the control lever to the horizontal (central position), this is the position which creates maximum tension in the operating cable. Pull the free end of the operating cable through the operating arm until it is finger tight and secure with screw into operating arm (do not over tighten).
- 4.9.7 Slide the operating arm fully to the right hand position and hold in position, slide the control lever relative to the cable until the cable retaining screw lines up with the hole in the spacer frame. This sets the control lever in the correct position. Hold the hexagonal locking bush with a spanner and tighten the retaining screw using the 2mm allen key. Move the control lever fully downwards and check that the left hand micro-switch operates the igniter and that the control valve spindle is fully depressed. Move the control lever upwards to the "off" position and check that the right hand (cut-off) micro-switch operates. Check that the control lever operates smoothly and safely.

## **Remote Control Fires - For Diagrams refer to section 2**

### **5.1 Removing the RC Burner Assembly (RC models)**

- 5.1.1 Prepare work area (lay down dust sheets etc.)
- 5.1.2 Remove the trim. Lift the fender and ash pan cover out of the way and put them in a safe location. Isolate the gas supply. Remove the glass panel, unscrewing the top and side retaining brackets, see page 10 & 11 of this manual for information. Carefully lift clear the glass panel. Remove the coals, front ceramic from the rail and fuel-bed base matrix. Remove all of the loose coals / pebbles and front ceramic rail. Unscrew the two pozi-drive fixing screws which secure the burner heat shield and remove it from the fire.
- 5.1.3 Unscrew the 4 off burner retaining screws on the side brackets, the burner should then be lifted out of the firebox.
- 5.1.4 To refit the burner assembly, re-assemble in reverse order and carry out a gas tightness test. Refit the burner heat shield then refit the coals referring to section 3 for the correct coal / pebble layout. Refit the glass panel and glass panel retaining trims. The fender and ash pan cover can now be re-positioned. Refit the trim.

### **5.2 Removing the Remote Gas Valve from the fire (RC models)**

- 5.2.1 Prepare work area (lay down dust sheets etc.)

- 5.2.2 Remove the burner assembly as described in section 5.1.
- 5.2.3 Remove the thermocouple wires from the valve, remove the main pipe, inlet pipe and pilot pipe from the valve.
- 5.2.4 Remove the valve retaining screws and lift clear. Re-assemble in reverse order and carry out a gas tightness test. Re-fit coals / pebbles as shown in section 3. The fender and ash pan cover can now be re-positioned.

### **5.3 Removing the Pilot Assembly (RC models)**

**Note : Because this appliance is fitted with an atmosphere sensing ‘Oxy-Pilot’ it is not possible to replace the thermocouple separately, because the thermocouple position is factory set to a tight tolerance. Any replacement of parts on the pilot requires a complete new pilot assembly.**

- 5.3.1 Prepare work area (lay down dust sheets etc.)
- 5.3.2 Remove the burner assembly as described in section 5.1.
- 5.3.3 Loosen the pilot nut and remove the two screws retaining the pilot assembly. Disconnect the thermocouple wires from the gas valve.
- 5.3.4 Re-assemble in reverse order, refit the burner heat shield then refit the coals referring to section 3 for the correct coal / pebble layout. Refit the glass panel and glass panel retaining trims. The fender and ash pan cover can now be re-positioned. Refit the trim.

### **5.4 Replacing the Batteries (RC Models)**

- 5.4.1 Prepare work area (lay down dust sheets etc.)
  - 5.4.2 Remove the trim / fret & ashpan cover.
  - 5.4.3 The battery pack is located on the front of the valve, see page 32 for position of battery cover on the control valve. Replace the batteries as necessary.
  - 5.4.4 The fender and ash-pan cover can now be re-positioned.
- NB The handset uses two AA sized alkaline batteries and should be replaced by removing the cover on the rear of the handset.

**ENSURE THE BATTERIES ARE CONNECTED TO THE CORRECT POLARITY  
POSITIVE (+), NEGATIVE (-)**

## FRET INFORMATION

To enable Customers to choose their own style of fret these fires are now available without frets. In order to maintain the efficient and safe operation of the fire it is important that any fret which is used must comply with the following dimensions. (figure 51). It is important to clean a fret in accordance with the instructions provided by your retailer as these vary depending on the surface finish of the fret.

**Fig. 51**

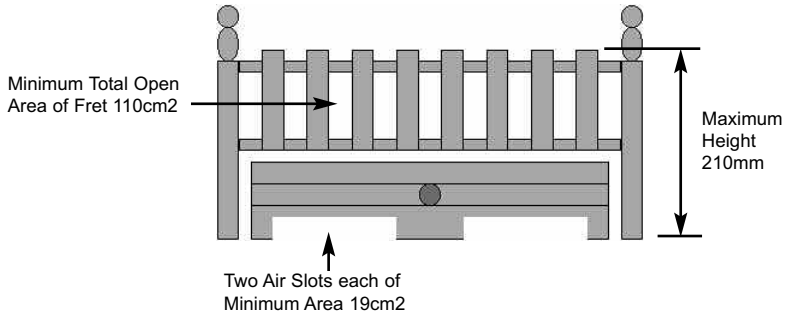

## PARTS SHORTLIST

Replacement of parts must be carried out by a competent person such as a registered gas installer. The part numbers of the replaceable parts are as follows, these are available from your local stockist, whose details may be found on the BFM Europe website, address as per rear page.

Complete pebble / ceramic set	B-110000
Pebble fuelbed base	B-108050
Pebble fuelbed front rail	B-105060
Replacement pebble set	B-110020
Complete coal / ceramic set	B-121600
Coal fuelbed base	B-121550
Coal fuelbed front rail	B-121560
Replacement coal set	B-121610
Glass panel	B-125630
Piezo Igniter	B-1320
Ignition wire manual models	B-67910
Ignition wire remote models	B-34690
NG manual gas valve	SP10689
NG slide valve	B-40980
NG RC gas control valve	B-160780
RC handset	B-168970
NG MC ODS pilot	B-38930
NG SC ODS pilot	B-49710
NG RC ODS pilot	B-170240

## SECTION SIX - USER INSTRUCTIONS

### 6.1 INSTALLATION INFORMATION

#### CONDITIONS OF INSTALLATION

It is the law that all gas appliances are installed only by a competent (e.g. Registered) Installer, in accordance with the installation instructions and the Gas Safety (Installation and Use) Regulations 1998. Failure to install appliances correctly could lead to prosecution. It is in your own interest and that of safety to comply with the law.

The fire may be fitted below a combustible shelf provided that the shelf is at least 200mm above the top of the appliance and the depth of the shelf does not exceed 150mm.

The fire may be installed below combustible shelves which exceed 150mm deep providing that the clearance above the fire is increased by 15mm for each 25mm of additional overhang in excess of 150mm.

**No purpose made additional ventilation is normally required for this appliance when installed in G.B. When installed I.E. please consult document I.S. 813 : 1996 Domestic Gas Installation which is issued by the National Standards Authority of Ireland. Any purpose made ventilation should be checked periodically to ensure that it is free from obstruction.**

If the chimney or flue has been previously used by appliances burning fuels other than gas they must be swept prior to the installation of this fire.

If this appliance is fitted directly on to a wall without the use of a fireplace or surround, soft wall coverings such as wallpaper, blown vinyl etc. could be affected by the heat and hot convection air and may discolour or scorch. This should be considered when installing or decorating.

The Model number of this appliance is as stated on the rating plate affixed to the control panel of the fire and the appliance is manufactured by:-

BFM Europe Ltd  
Trentham Lakes  
Stoke on Trent  
ST4 4TJ



## **ABOUT YOUR NEW KENILWORTH HE, LINEAR HE, DIAMOND HE OR EXPRESSION HE (High Efficiency) GAS FIRE**

The Flavel Kenilworth, Linear, Diamond or Expression High Efficiency coal / pebble effect gas fires incorporate a unique and highly developed fuel bed which gives the realism of a loose coal / pebble layout combined with realistic flames and glow. The use of durable ceramic material in the construction of the fuelbed components ensures long and trouble free operation.

When first using the new fire a slight smell may be noticed. This is due to starch used in the manufacture of the soft ceramic coals / pebbles, it is non-toxic and will soon disappear.

Please take the time to fully read these instructions as you will then be able to obtain the most effective and safe operation of your fire.

### **IMPORTANT SAFETY INFORMATION**

#### **WARNING**

**This appliance has a naked flame and as with all heating appliances a fireguard should be used for the protection of children, the elderly and infirm. Fireguards should conform to B.S. 8423 : 2002 (Fireguards for use with gas heating appliances).**

It is important that this appliance is serviced at least once a year by a registered gas installer and that during the service the fire is removed from the fire opening and the chimney or flue visually checked for fallen debris or blockages which must be removed. The chimney should also be checked to ensure clearance of flue products. We recommend that during the annual service, replacement of the Oxypilot is carried out. **This is a condition of the manufacturers guarantee.**

**After installation or during servicing a spillage test must always be carried out.**

Rubbish of any type must NEVER be thrown onto the fuel bed, this could affect safe operation and damage the fire.

Any debris or deposits should be removed from the fuel bed from time to time. This may be carried out by referring to the cleaning section as described later in this book. Only the correct number and type of coals or pebbles must be used and only complete and genuine replacement sets must be used.

Always keep furniture and combustible materials well clear of the fire and never dry clothing or items either on or near to the fire. Never use aerosols or flammable cleaning products near to the fire when it is in use.

## 6.2.1 OPERATING THE FIRE (MANUAL CONTROL MODELS)

The controls are located behind the ashpan cover which is situated behind the ashpan / fender. The controls, comprise a control valve to adjust the gas flow and a push button piezo igniter. To light the fire proceed as follows:-

- 6.2.1.1 Depress the control knob and turn anti-clockwise to the position marked pilot. Hold in the control knob for a few seconds to allow the gas to reach the pilot.
- 6.2.1.2 Continue to hold-in the control knob and press the igniter button. If the pilot does not light, continue to press the igniter button until ignition occurs. The pilot flame can be seen by looking at the left hand side front bottom corner of the glass panel. When the pilot has lit, continue to hold the control knob in for 5-10 seconds to allow the thermocouple to heat up, if the pilot goes out when the control knob is released, repeat the lighting sequence.

In the unlikely event of a failure of the igniter, the fire can be lit as follows :-  
Remove the fret / ashpan cover, depress the control knob and turn anti-clockwise to the position marked pilot. Hold in the control knob for a few seconds to allow the gas to reach the pilot. Insert the tip of a lit taper in behind the front ceramic rail on the left hand side. This will light the pilot flame. When the pilot has lit, continue to hold the control knob in for 5-10 seconds to allow the thermocouple to heat up, if the pilot goes out when the control knob is released, repeat the lighting sequence.

- 6.2.1.3 After lighting, turn the control knob in the anti-clockwise direction to the high position and the main burner will light. For most efficient performance allow the fire to warm up for a few minutes with the gas control on maximum.
- 6.2.1.4 The gas control can be turned clockwise from the maximum position to give the desired heat output.

### **WARNING**

**If the fire goes out for any reason or is turned off and it is necessary to re-light the fire it is important to allow the fire to cool for 3 minutes before attempting to re-light it.**

## 6.2.2 OPERATING THE FIRE (SLIDE CONTROL MODELS)

The controls comprise a control lever, to turn the fire on and off and adjust the gas rate. The control lever is located at the top right hand side of the fire. Depressing the control lever fully operates the igniter and lights the pilot flame and ignition rate gas. Once the pilot is established raising the lever allows medium and finally high gas settings. The fire is turned off when the control lever is fully raised.

To light the fire proceed as follows:-

- 6.2.2.1 Depress the control lever fully downwards to the position marked "Z". Hold down the control lever for a few seconds to allow the gas to reach the pilot.
- 6.2.2.2 The fire will then begin its ignition sequence. If the pilot does not light, continue to press the control lever until ignition occurs. The pilot flame can be seen by looking underneath the front ceramic rail, above the burner heat shield, at the front left hand side of the fuel. When the pilot has lit, continue to hold the control lever down for 5-10 seconds to allow the thermocouple to heat up, before releasing the lever apply one firm downwards push to ensure that the f.s.d. valve is fully latched, if the pilot goes out when the control lever is released, repeat the lighting sequence.

In the unlikely event of a failure of the igniter, firstly check the operation of the 1.5V battery and if necessary replace with a 'AA' size alkaline battery. **It is important that only an alkaline battery is used, otherwise premature battery failure and leakage may result.** If the appliance still fails to light the fire can be lit as follows:

Remove the fret & ashpan cover. Depress the control lever fully downwards to the position marked "Z". Hold in position for a few seconds to allow the gas to reach the pilot. Insert the tip of a lit taper in behind the front ceramic rail on the left hand side. This will light the pilot flame and low rate gas. When the pilot has lit, continue to depress the control lever in for 5-10 seconds to allow the thermocouple to heat up before releasing the control lever apply one firm downwards push to ensure that the f.s.d. valve is fully latched.

- 6.2.2.2 After lighting, move control lever up to the high position and the main burner will light. For the most efficient performance allow the fire is to warm up for 10 minutes with the control lever set to high.
- 6.2.2.3 The gas control can be moved from the high to low position to give the desired heat output and the flame control adjusted to give the most pleasing flame effect or maximum glow.
- 6.2.2.4 To turn the fire off, FULLY raise the control lever to the OFF position.

## **WARNING**

**If the fire goes out for any reason or is turned off and it is necessary to re-light the fire it is important to allow the fire to cool for 3 minutes before attempting to re-light it.**

## 6.2.3 LIGHTING THE FIRE - REMOTE CONTROL MODELS

- 6.2.3.1 Ensure valve power isolation switch is in the on position - see figure 4  
Hold the handset with one hand ensuring your hand is wrapped around the back and that your hand is in contact with both sides of the handset.  
The green light of the “unlock” symbol should light. See figure 1 below.

Fig. 1



- 6.2.3.2 Press and hold the power button continuously until the word “PILOT” appears at the bottom left of the display as shown overpage in figure 2, (this typically takes two seconds). The burner will now light at maximum heat input level and will display “MAX” in the bottom left hand side of the display as shown in figure 3 overpage. **For most efficient performance leave the fire on high when lighting from cold for ten minutes.**

NOTE : If the power button is pressed for too long or too short a time or the grip on the handset is not firm or is released too soon, the lighting sequence will be interrupted and not complete. The reason for the remote control having this strict start sequence is for safety reasons so that the starting operation of the fire will be most unlikely to be done other than intentionally by an adult.

**Fig. 2 - "PILOT" displayed**



"PILOT" displayed on handset during ignition sequence (typically takes two seconds)

**Fig. 3 - "MAX" & large flame symbol displayed**



"MAX FLAME" displayed on handset when burner is lit to maximum rate

## 6.2.3 LIGHTING THE APPLIANCE - REMOTE CONTROL MODELS (CONTINUED)

- 6.2.3.3 To decrease the heat input level of the burner hold the handset as described in section 6.2.3.1 to unlock the keypad then press and release the - button. Pressing and releasing the - button will lower the heat input level one step at a time. Pressing the - button continuously will move the heat input level to the minimum, see figure 4 below.

**Fig. 4**



- 6.2.3.4 To increase the heat input level of the fire's burner hold the handset as described in section 6.2.3.1 to unlock the keypad then press and release the + button. Pressing and releasing the + button will increase the heat input level one step at a time. Pressing the + button continuously will move the heat input level to the maximum.
- 6.2.3.5 To turn the fire off hold the handset as described in section 6.2.3.1 to unlock the keypad then press and release the power button. The burner will go out.

6.2.3.6

**If you are not intending to use the fire for a long period (i.e. over the summer months) the battery life can be extended by sliding the power isolator switch to the left (to the “0” position away from the “1” position) on the valve itself, which is located behind the ashpan cover on the fire.**

6.2.3.7

**In the event of loss of the remote handset, as a backup the fire can be controlled from the valve, which is located behind the ashpan cover on the fire, see section 6.3 for full manual operating instructions. If your fire does not operate manually please consult the troubleshooting chart on the rear page of this manual.**

6.2.3.8

If the handset is misplaced you can “page it” by pressing the (+) button only on the control valve on the fire for a period of 5 seconds. The handset will flash and make an audible noise to help you locate it. Once you find the handset with one hand ensure your hand is wrapped around the back and that your hand is in contact with both sides of the handset then the audible noise will cease. The flashing and sound will last for 60 seconds each time the handset is paged as described. If not found in 60 seconds page the handset again until located.

**IMPORTANT NOTE : THE BATTERIES SHOULD BE REPLACED WITH GOOD QUALITY ALKALINE BATTERIES WHEN REQUIRED, THE BATTERY LIFE IS EXPECTED TO BE A MINIMUM OF 12 MONTHS WITH NORMAL USAGE. FOR BEST PERFORMANCE BFM EUROPE RECOMMEND THE USE OF ENERGIZER BATTERIES WITH IT'S PRODUCTS.**



### 6.3 MANUAL OPERATION OF REMOTE CONTROL & ELECTRONIC FIRE CONTROL MODELS

6.3.1 These products can therefore be operated manually should the need arise. The control valve is located at the base of the fire as shown below in figure 5.

Fig. 5

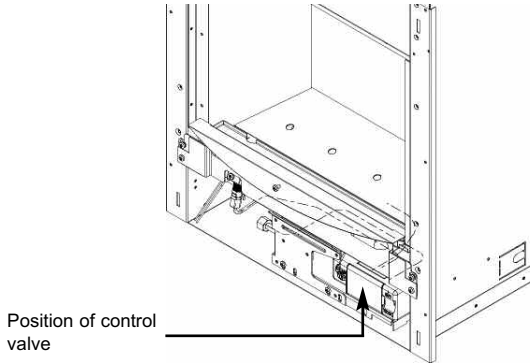

6.3.2 Ensure that the power isolation switch is in position "1" and the power indicator light is illuminated (red) as shown in figure 6 below.

Fig. 6

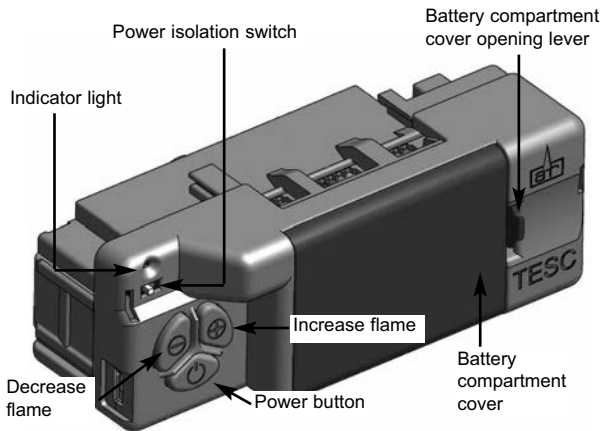

- 6.3.3 To operate the fire press and hold the “power” button as shown in figure 2 on the previous page for two seconds, release as soon as the red indicator light in figure 2 on the previous page illuminates. The burner will start its ignition sequence and light to the maximum heat input level.
- 6.3.4 To reduce the heat input, press and release the (-) button to lower the heat input level one step at a time. Pressing the (-) button continuously will move the heat input level to the minimum.
- 6.3.5 To turn the fire off, press the power button and the burner will stop.

6.3.6

**If you are not intending to use the fire for a long period (i.e. over the summer months) the battery life can be extended by sliding the power isolator switch to the left (to the “0” position away from the “1” position) on the valve itself, which is located behind the ashpan cover on the fire.**

## 6.4 REPLACING THE BATTERIES ON REMOTE CONTROL MODELS

- 6.4.1 Remove the ashpan cover, locate the control valve battery cover at the right hand side of the burner, slide the power isolator switch to the “0” position (to the left).
- 6.4.2 Remove the battery cover and replace the 3 off AA batteries with good quality Alkaline items, BFM Europe recommend the use of “Energizer” batteries. **It is important that only an alkaline battery is used, otherwise premature battery failure and leakage may result.**
- 6.4.3 Replace the battery cover and turn the power isolator switch to the “1” position (to the right).
- 6.4.4 Replace the ashpan cover and operate the fire as normal.
- 6.4.5 On remote control models fit two off AA batteries to the handset in the direction shown inside the handset moulded into the plastic.

## 6.5 REPLACING THE BATTERY ON SLIDE CONTROL MODELS

- 6.5.1 Remove the ashpan cover, locate the battery holder / ignition generator unit at the right hand side of the burner.
- 6.5.2 Unscrew the retaining cap, remove and replace the 1 off AA battery, then replace the retaining cap. BFM Europe recommend the use of “Energizer” batteries. **It is important that only an alkaline battery is used, otherwise premature battery failure and leakage may result.**

## **6.6 SPILLAGE MONITORING SYSTEM - Applicable to all models**

This appliance is fitted with a spillage monitoring system which shuts down the fire if the evacuation of combustion products from the fire is affected by a partially or fully blocked flue.

If this system operates the fire will go out. If this occurs, leave the fire for at least three minutes then follow the lighting procedure as described in the previous section. **In the event of repeated operation a registered gas installer must be called to investigate and rectify the cause.**

## 6.7 SETTING THE TIME, DATE & TEMPERATURE ON THE REMOTE HANDSET

- 6.7.1 Fit the 2 off AA batteries to the handset by removing the cover on the rear of the handset and inserting the batteries, ensure the correct +/- polarity is observed. Following insertion of the batteries the screen displayed will be as shown below in figure 7.

Fig. 7



- 6.7.2 Hold the handset with one hand ensuring your hand is wrapped around the back and that your hand is in contact with both sides of the handset. The green light of the “unlock” symbol should light and the screen displayed will be as shown overpage in figure 8.
- 6.7.3 The “H” symbol as indicated in figure 8 overpage indicates that the timer can now be set in either 24hr or 12hr mode. Press the + or - buttons on the handset to toggle between the two settings, figure 8 overpage displays the 24hr mode.

**Fig. 8**



6.7.4 When the 24hr or 12hr time display option has been chosen and you are ready to confirm the setting you want press the SET button on the handset to progress to setting the day of the week as shown overpage in figure 9.

6.7.5 Press and release the + and - buttons on the handset until the correct day of the week is shown on the handset display

Mo = Monday  
Tu = Tuesday  
We = Wednesday  
Th = Thursday  
Fr = Friday  
Sa = Saturday  
Su = Sunday

6.7.6 Press SET to accept the day of the week and progress to setting the hour of the day.

**Fig. 9**



6.7.7 As shown above in figure 9 the time on the handset can now be set by using the + and - buttons to change the hour to the correct hour then press SET to store and to move to setting the minute. Repeat this process for setting the minute to the correct minute then press SET to store.

6.7.8 The handset will then display the temperature setting screen as shown overpage in figure 10, the option to choose either Celsius or Fahrenheit can be chosen, these settings are shown as either C or F. Use the + and - buttons to toggle between these two options then press SET to store. The important settings have now been completed so press and hold the SET button for a few seconds and this will exit the set-up menu.

**Fig. 10**



6.7.9 The control is now ready for use with the burner.

6.7.10 If the handset is misplaced you can “page it” by pressing the (+) button only on the control valve on the fire for a period of 5 seconds. The handset will flash and make an audible noise to help you locate it. Once you find the handset with one hand ensure your hand is wrapped around the back and that your hand is in contact with both sides of the handset then the audible noise will cease. The flashing and sound will last for 60 seconds each time the handset is paged as described. If not found in 60 seconds page the handset again until located.

## 6.8 ADVANCED SETTINGS MENU OF THE REMOTE CONTROL

### 6.8.1 Snooze mode in manual operation

- 6.8.1.1 Snooze mode is a time period which can be set which will turn the fire automatically off after a certain time period has elapsed.
- 6.8.1.2 Hold the handset with one hand ensuring your hand is wrapped around the back and that your hand is in contact with both sides of the handset. The green light of the “unlock” symbol should light. The snooze time period can be set either before or during manual operation of the fire.
- 6.8.1.3 With the handset held as described above, press the mode button to scroll through the functions until the symbols MAN and Zzz are flashing at the top of the display as shown below in figure 11.
- 6.8.1.4 Press and release the set button and this will put the control into the manual snooze mode.
- 6.8.1.5 The default time period in snooze mode is 1:00 hour.

**Fig. 11**





6.8.1.6 Pressing the set button again will now show you the snooze time period remaining. The snooze time period can be adjusted by pressing the + or - buttons on the handset. This time period can be set ranging from 1 minute to 4:00 hours.

6.8.1.7 To adjust the snooze period, hold the handset with one hand ensuring your hand is wrapped around the back and that your hand is in contact with both sides of the handset. The green light of the “unlock” symbol should light. Press the set button and the screen will show how long is left of the snooze period as shown below in figure 12.

**Fig. 12**



6.8.1.8 To adjust the snooze period use the + and - buttons to increase or decrease the snooze period for any period between 1 minute and 4:00 hours.

6.8.1.9 When the correct snooze period is indicated on the handset, press the set button to store the required time period, or alternatively the handset can be left for a few seconds and the period will be stored automatically.

6.8.1.10 When the countdown timer for the snooze period has reached zero the fire will turn off (as if you had turned the fire off manually).

## 6.8.2 Thermostatic mode

**PLEASE NOTE : Thermostatic mode of this fire will only allow regulation of the room temperature by the fire when it has been already lit via manual operation of the handset. It will not allow the fire to light automatically due to low ambient room temperature and should therefore not be relied upon for frost protection purposes.**

6.8.2.1 Hold the handset with one hand ensuring your hand is wrapped around the back and that your hand is in contact with both sides of the handset. The green light of the “unlock” symbol should light.

6.8.2.2 With the handset held as described above, press and release the mode button several times as necessary until the display has the thermometer symbol flashing at the top of the display. Press the set button to enter this mode, as shown below in figure 13.

Fig. 13



6.8.2.3 Press the set button again to see the temperature setting that is set (the default is 24 degrees celsius). If a different set temperature is required, whilst the display is showing this set temperature, press the + and - buttons to alter this setting, press the set button to store the required temperature, or alternatively the handset can be left for a few seconds and the temperature will be stored automatically.

6.8.2.4 If at any time the power button is operated during thermostat mode the control will cancel any thermostat operation and return the control to manual mode.

6.8.2.5 **IMPORTANT NOTE : Thermostat mode will not light the fire automatically and will only regulate between the maximum and minimum burner setting. The fire must be lit manually via the handset and then you enter thermostat mode as described in this section and set the temperature. When no longer requiring thermostat mode turn off the burner and the handset will return to manual mode.**

## 6.9 RE-ASSEMBLING THE CERAMICS AND FUEL BED - COAL MODELS

**NOTE :** The position of the fuel-bed components are critical to the performance of the product. Therefore please ensure that the fuel-bed components are positioned as described in the following section prior to requesting a service call due to soot build up, poor flame pattern etc.

- 6.9.1 Remove the glass panel and retaining trims as detailed on page 11 & 12. Place the ribbed ceramic fuelbed base on top of the fuelbed support and pull fully forwards to the burner. **Make sure that the fuelbed base is located centrally in the fire box. Ensure that the fuelbed base fit fully down onto the fuel bed support and is not lodged on the burner. Ensure the air ports as indicated by the arrows are not blocked by the fuel-bed matrix.** See figure 14 & 15 below.

Fig. 14

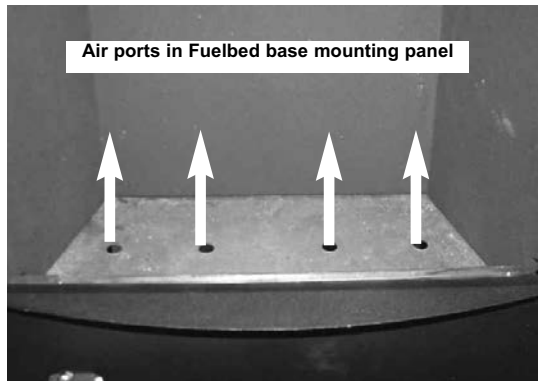
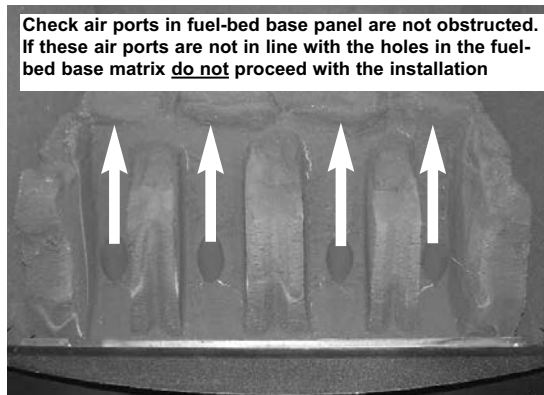
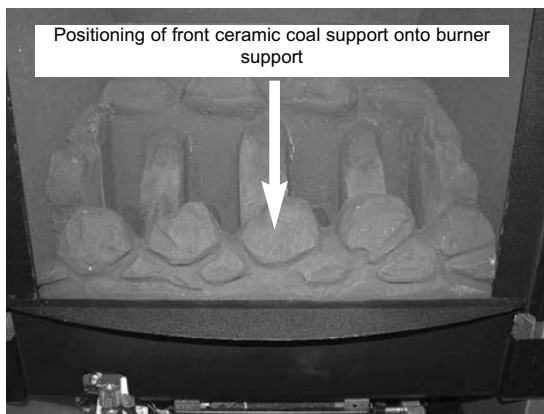

Fig. 15



6.9.2 Position the front ceramic coal support onto the burner support as shown below in figure 16.

**Fig. 16**



6.9.3 Fit the front row left hand coal as shown below in figure 17.

**Fig. 17**

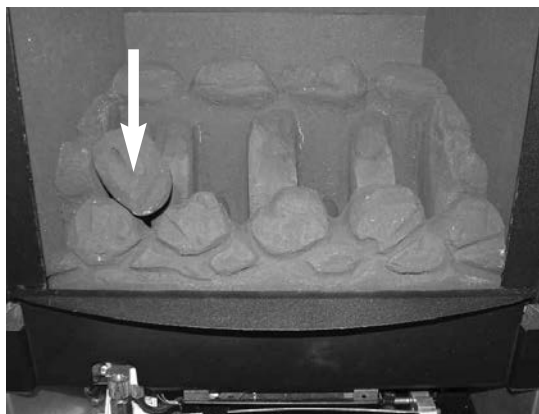

6.9.4 Fit the front row left hand side central coal as shown below in figure 18.

**Fig. 18**

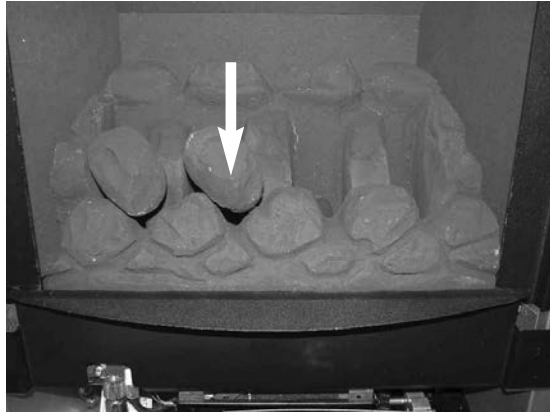

6.9.5 Fit the front row right hand side central coal as shown below in figure 19.

**Fig. 19**

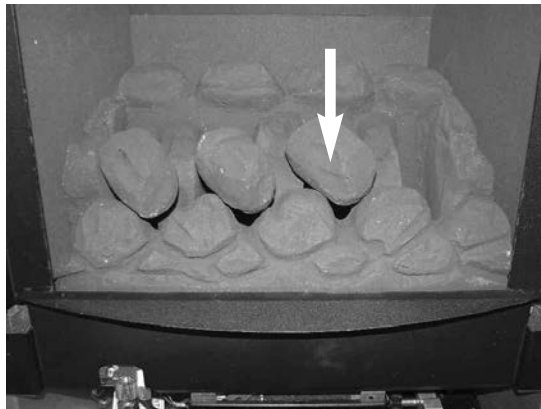

6.9.6 Fit the front row right hand coal as shown below in figure 20.

**Fig. 20**

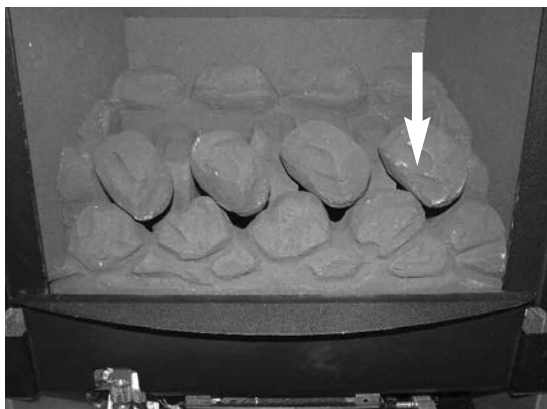

6.9.7 Fit the rear row of 3 coals as shown below in figure 21.

**Fig. 21**

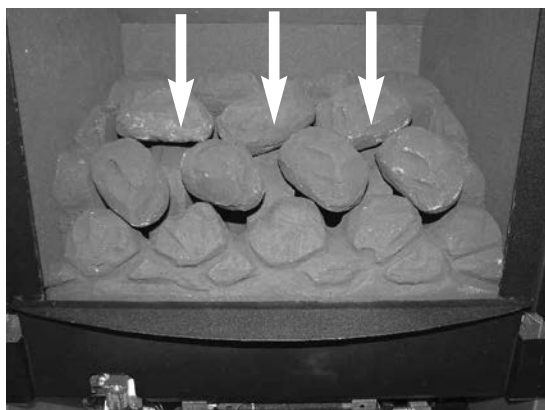

The exact position and fit of the coals may be very finely adjusted to give the most pleasing and random appearance.

**Warning : Use only the coals supplied with the fire. When replacing the coals remove the old coals and discard them. Fit a complete set of coals of the correct type. Do not fit additional coals or any coals other than a genuine replacement set.**

**To ensure that the release of fibres from these R.C.F (Refractory Ceramic Fibre) articles is kept to a minimum, during installation and servicing we recommend that you use a HEPA filtered vacuum to remove any dust accumulated in and around the appliance before and after working on the appliance. When replacing these articles we recommend that the replaced items are not broken up, but are sealed within heavy duty polythene bags, clearly labelled as “RCF waste”. RCF waste is classed as a “stable”, non reactive hazardous waste and may be disposed of at a landfill licensed to accept such waste Protective clothing is not required when handling these articles, but we recommend you follow the normal hygiene rules of not smoking, eating or drinking in the work area, and always wash your hands before eating or drinking.**

6.9.8            Replace the glass panel and retaining trims as described on pages 11 & 12

**NEVER USE THE FIRE WITHOUT THE GLASS PANEL IN POSITION, OR IF BROKEN OR CRACKED.**



## 6.10 RE-ASSEMBLING THE CERAMICS AND FUEL BED - PEBBLE MODELS

- 6.10.1 Remove the glass panel and retaining trims as detailed on page 11 & 12. Place the ribbed ceramic fuelbed base on top of the fuelbed support and pull fully forwards to the burner. **Make sure that the fuelbed base is located centrally in the fire box. Ensure that the fuelbed base fit fully down onto the fuel bed support and is not lodged on the burner. Ensure the air ports as indicated by the arrows are not blocked by the fuel-bed matrix.** See figure 22 & 23 below.

Fig. 22

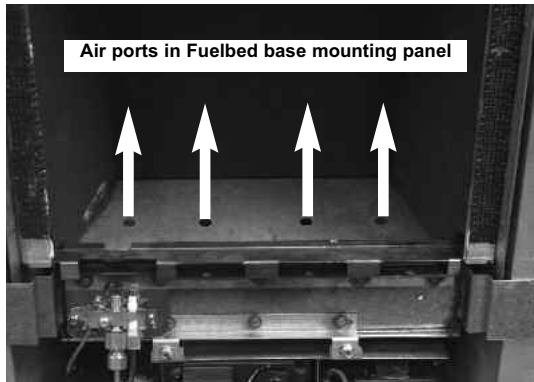
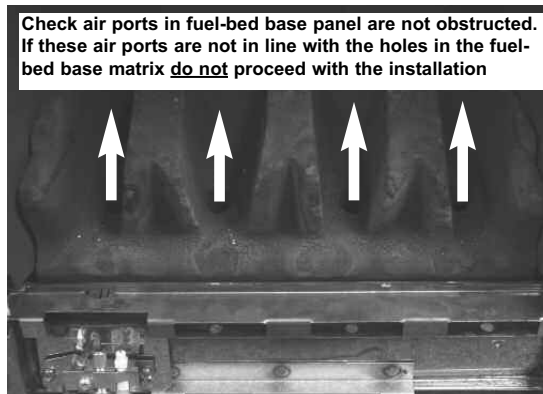
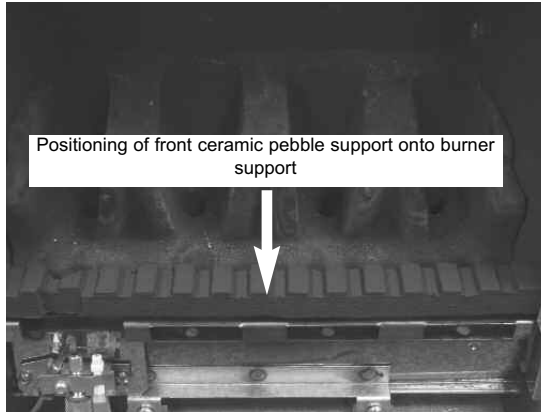

Fig. 23



6.10.2 Position the front ceramic pebble support onto the burner support as shown below in figure 24.

**Fig. 24**



6.10.3 Fit four of the specially shaped pebbles as shown below in figure 25. Ensure that the cut-out in the rear face of the pebbles is positioned as indicated. The 4 off specially shaped pebbles are packed in a bag with a label “FR” on them.

**Fig. 25**

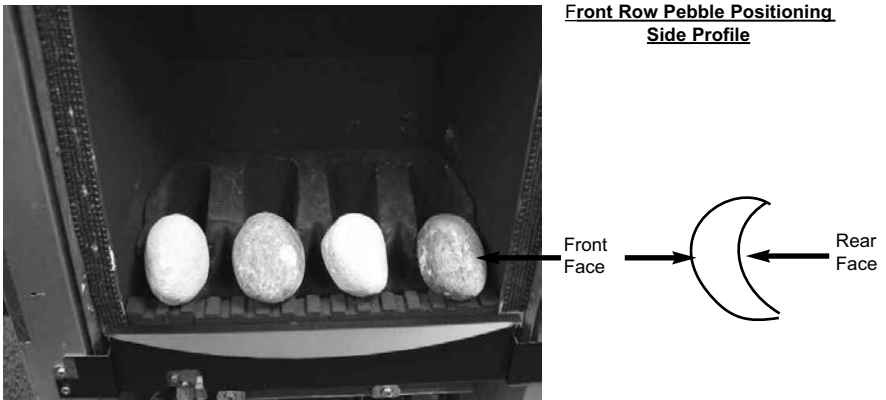

6.10.4 Select three of the large pebbles and position on the three central ribs in the fuelbed as indicated in figure 26 below.

**Fig. 26**

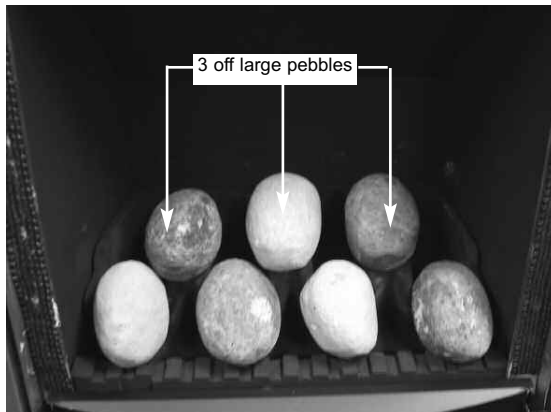

6.10.5 Select the two small pebbles and arrange along the second row of the fuelbed, see figure 27 below.

**Fig. 27**



6.10.6 Select the four remaining large pebbles and position as shown along the rear of the fuel-bed base in figure 28 below.

**Fig. 28**

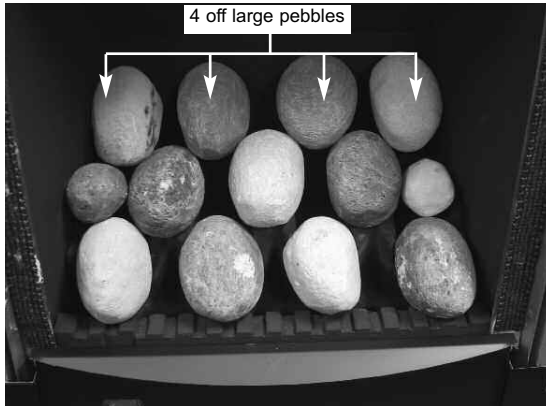

6.10.7 Do a final check that the pebbles are layed out as shown below in figure 29

**Fig. 29**

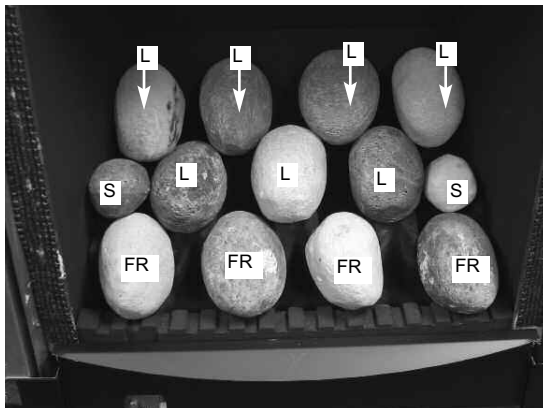

The exact position and fit of the pebbles may be very finely adjusted to give the most pleasing and random appearance.

**Warning : Use only the pebbles supplied with the fire. When replacing the pebbles remove the old pebbles and discard them. Fit a complete set of pebbles of the correct type. Do not fit additional pebbles or any pebbles other than a genuine replacement set.**

**To ensure that the release of fibres from these R.C.F (Refractory Ceramic Fibre) articles is kept to a minimum, during installation and servicing we recommend that you use a HEPA filtered vacuum to remove any dust accumulated in and around the appliance before and after working on the appliance. When replacing these articles we recommend that the replaced items are not broken up, but are sealed within heavy duty polythene bags, clearly labelled as “RCF waste”. RCF waste is classed as a “stable”, non reactive hazardous waste and may be disposed of at a landfill licensed to accept such waste Protective clothing is not required when handling these articles, but we recommend you follow the normal hygiene rules of not smoking, eating or drinking in the work area, and always wash your hands before eating or drinking.**

6.10.7            Replace the glass panel and retaining trims as described on pages 86 & 87.

**NEVER USE THE FIRE WITHOUT THE GLASS PANEL IN POSITION, OR IF BROKEN OR CRACKED.**

#### **6.11            CLEANING THE FIRE - WARNING**

Before attempting any cleaning operation ensure that the fire has been allowed to fully cool. Consult your retailer to determine what trim / fret / fascia option was supplied with your fire. If a real Brass fret was supplied with the fire it will therefore will discolour with use and should be cleaned with a proprietary metal polish. A laquered brass fret should not discolour and should only be cleaned with a clean, damp cloth. The chrome, black & brass effect trims and chrome effect fret that are supplied with the fire (dependent upon model chosen) should only also be cleaned with a clean, damp cloth.

The trim is best cleaned in position on the fire when the appliance is not running and is cool. Black painted metal parts should be gently cleaned with a damp cloth.

## 6.12 CLEANING THE FUEL-BED / GLASS PANEL

We do not recommend cleaning of the coals or fuelbed components as these are fragile and damage may result. **None of these parts must be washed or exposed to any cleaning agents or water.** Any damaged parts must be replaced by contacting your dealer or telephoning BFM Europe Ltd. on the number stated on the rear cover of this book. The coals must only be replaced with a complete and genuine replacement set and the fire must never be run with the wrong number or damaged coals or pebbles. The fuel-bed must be carefully re-assembled as stated in section 6.9/6.10, pages 75-83.

To clean the glass panel, please remove it from the product as described overpage. Use a clean damp cloth and ceramic glass cleaner to remove any stains or deposits from the glass panel. Do not use scouring pads as this may scratch the surface finish of the glass panel.

**PLEASE NOTE** :- The glass will require cleaning periodically. Condensation produced by the products of combustion will create marks on the inside face of the glass panel.

## 6.13 REMOVING AND RE-FITTING THE GLASS PANEL

- 6.13.1 Remove the top glass retaining cover from the product. It is secured via the two screws as indicated, see figure 30 below.

**Fig. 30**

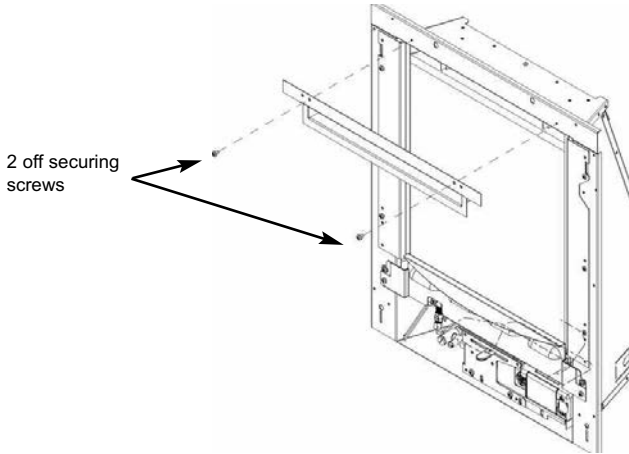

- 6.13.2 Remove the left and right hand side glass securing brackets from the product. They are secured via 3 off screws each side. Support the glass panel to prevent it falling forwards when the side trims are removed. See figure 31 below.

**Fig. 31**

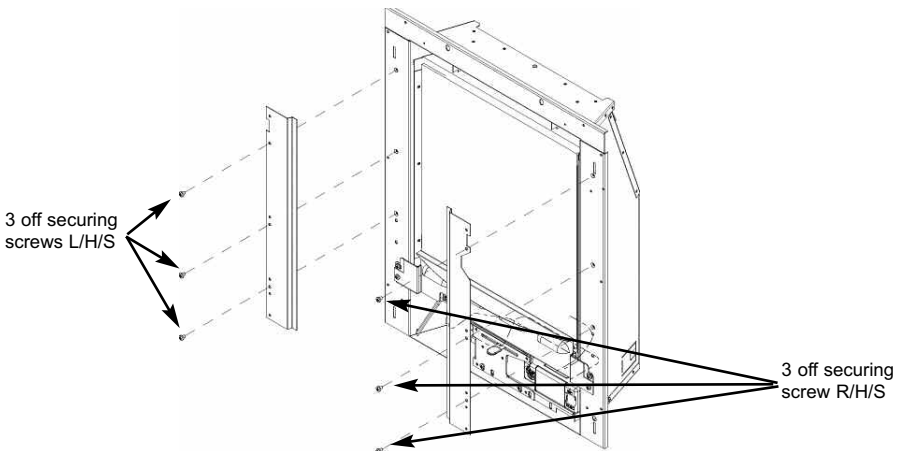

- 6.13.3 Lift the glass panel forwards and clear from the firebox, taking care not to damage the glass panel. See figure 32 below.

**Fig. 32**

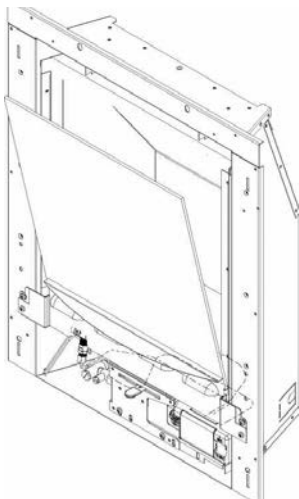

- 6.13.4 Replace the glass panel in reverse order, do not use the fire under any circumstances if the glass panel is damaged or cracked in any way.



## 6.14 REMOVAL AND RE-FITTING THE TRIMS / FRETS / FASCIA'S

### Models supplied with one piece trim & fret / ashpan cover

- 6.14.1 Fit the outer trim assembly to the firebox with the magnets provided.
- 6.14.2 Remove the fret & ashpan cover from the packaging. Place fret up to the front radiused burner heat shield .
- 6.14.3 Place ashpan cover under fret assembly and centralise.

### Models supplied with fascia's

- 6.14.4 Refer to the fitting instructions supplied with the fascia for advice on removal / re-fitting.

**NOTE :** Some models in this range are not supplied with a fret from the factory, therefore please consult your local retailer for fitting advice on the type of fret supplied with these models.

## 6.15 USER REPLACEABLE PARTS

The only user replaceable parts on this fire are the glass panel, fuelbed components and coals / pebbles which may be replaced as described in section 6.9/6.10. In order to replace the fuel-bed components, the glass panel of the appliance will need to be removed, please refer to pages 86 & 87 of this book for details on how to remove the glass panel.

Replacement of any other parts must be carried out by a competent person such as a registered gas installer. The part numbers of the user replaceable parts are as follows, these are available from BFM Europe Ltd. who may be contacted at the number on the rear cover of this book.

Complete pebble / ceramic set	B-110000
Pebble fuelbed base	B-108050
Pebble fuelbed front rail	B-105060
Replacement pebble set	B-110020
Complete coal / ceramic set	B-121600
Coal fuelbed base	B-121550
Coal fuelbed front rail	B-121560
Replacement coal set	B-121610
Glass panel	B-125630

Due to our policy of continual improvement and development the exact accuracy of illustrations and descriptions contained in this book cannot be guaranteed.

**TROUBLE SHOOTING ADVICE FOR REMOTE CONTROL & ELECTRONIC  
FIRE CONTROL MODELS PRIOR TO REQUESTING A SERVICE CALL**

Please locate the Indicator light on the control valve behind the ashpan cover (see figure 6 on page 64), if it shows **any** of the following flashing sequences then the problem requires the batteries in the control valve and / or handset changing, **be advised that service calls as a result of batteries requiring being changed in the product or handset are chargeable.**

- a) If the red indicator light flashes **ONCE** every ten seconds the batteries in the control valve require changing, see section 6.4
- b) If the red indicator light flashes **TWICE** every ten seconds the batteries in the handset require changing, see section 6.4
- c) If the red indicator light flashes **THREE** times every ten seconds the batteries in the control valve and the handset require changing, see section 6.4

If these red indicator light flashes are ignored then eventually this will show as a flash every second and your fire will cease to operate until the batteries are changed.

If a permanent red indicator light is shown after attempting to ignite the fire this signifies no spark or no gas at the pilot and therefore a service call will be required to diagnose the fault.

**PLEASE ENSURE THIS ADVICE IS FOLLOWED TO AVOID BEING CHARGED FOR A SERVICE CALL AS A RESULT OF BATTERIES REQUIRING TO BE CHANGED.**

**Part No. B-1002332  
Issue 2**



At the heart of your home

BFM Europe Ltd.  
Trentham Lakes  
Stoke-on-Trent  
Staffordshire  
ST4 4TJ

[www.bfm-europe.com](http://www.bfm-europe.com)

**Telephone - General Enquiries :**  
**Telephone - Service :**

**(01782) 339000**  
**(01782) 339008**