

Generation 6 Samsung Heat Pump Installation Manual



**REGISTER THIS PRODUCT
ONLINE WITHIN 28 DAYS OF
COMMISSIONING**

UNITED KINGDOM / IRELAND



Heat Pump Commissioning Sheet For Extended Warranty (7 Years)

**MUST BE COMPLETED AND
THEN REGISTERED ONLINE TO
COMPLETE WARRANTY**

Home owner

Address

Contact No.

Email

Date Unit Installed

Date Unit Commissioned

Has customer training been carried out? Y N

Company Name

Company/Installer Address

Installer Name

Contact Number

Email

EHS Approved Installer?

Will you be maintaining the unit? Y N

Outdoor Unit Information

Model Number **Serial Number**

Unit Location **Header/Buffer Tank /HEX installed?**

Strainer <input type="text"/>	Glycol added <input type="text"/>	Glycol Concentration <input type="text"/>
Fuse Rating <input type="text"/>	Mains Cable Size <input type="text"/>	Space around unit <input type="text"/>
Drainage For Outdoor Unit <input type="text"/>	Approx System Volume (L) <input type="text"/>	Unit Correctly Mounted <input type="text"/>
Water System Flushed <input type="text"/>		Water System Filled And Purged <input type="text"/>
Flow sensor fitted <input type="text"/>		Flow And Return Lines Insulated <input type="text"/>

*Glycol level around 20% check with glycol manufacture for details

Outdoor Unit Operation Data

Power Supply <input type="text"/>	Running Amps <input type="text"/>	Delta T (ΔT) <input type="text"/>
Ambient Temp <input type="text"/>	Air On Temp <input type="text"/>	Air Off Temp <input type="text"/>
Return Temp In <input type="text"/>	Flow Temp Out <input type="text"/>	

Please continue on next page

Heat Pump Commissioning Sheet For Extended Warranty (7 Years)

MUST BE COMPLETED AND THEN REGISTERED ONLINE TO COMPLETE WARRANTY

Heating Controls

Ground Floor Heat Emitter	<input type="text"/>	Type of Control Used	<input type="text"/>	Serial Number	<input type="text"/>
1st Floor Heat Emitter	<input type="text"/>	Type of Control Used	<input type="text"/>	Blending Valve Fitted	<input type="text"/>

Type of control i.e. Underfloor heating system, programmable room stat, etc.

Tank And Control Kit (MIM) Information

Tank Manufacture	<input type="text"/>	Model Number	<input type="text"/>	Serial Number	<input type="text"/>
Control Kit Model No. (CN\DN)	<input type="text"/>	Control Kit Serial No.	<input type="text"/>	Control Kit Location Cylinder Mounted (Y/N?)	<input type="text"/>
Tank Capacity (L)	<input type="text"/>	Solar Installed	<input type="text"/>	Blending Valve Fitted	<input type="text"/>
Cylinder water Temp at Startup	<input type="text"/>	Cylinder water Temp after 30mins	<input type="text"/>	Water Flow Temp?	<input type="text"/>
Fuse Rating For Mim Unit	<input type="text"/>	Cable Size	<input type="text"/>	Water Flow Rate (L/min)	<input type="text"/>
Immersion Heater Volts	<input type="text"/>	Flow And Return Lines Insulated	<input type="text"/>	Benchmark Book Completed	<input type="text"/>
Tank Sensor Fitted	<input type="text"/>	Vented or Unvented	<input type="text"/>		<input type="text"/>

Space Heating Field Settings

Menu Code	Function	Default	Site Settings
2011	Low Ambient temp for weather comp		+2
2012	High Ambient temp for weather comp		+15
2021	Flow temperature at low ambient point (2011) Zone 1		45°C
2022	Flow temperature at high ambient point (2012) Zone 1		35°C
2091	External Thermostat Application #1		1 Use/Signal only ON/OFF

Settings for Twin Heat Pump Installation & Hybrid Systems

Menu Code	Function	Default	Site Settings
4021	Enables control output for back up heat pump (0=No 1=Yes)	0	
4024	Ambient temperature below which the slave will assist	0 Use (Hysteresis Thermo On/Off)	
4031	Tells the Master unit that a backup boiler is fitted (0=No 1=Yes)	0	
4032	Tells the Master unit to use the boiler as back up at the value of 4033. (Set to 1)	0	
4033	Ambient condition for the boiler to be enabled	-15	

Heat Pump Commissioning Sheet For Extended Warranty (7 Years)

MUST BE COMPLETED AND THEN REGISTERED ONLINE TO COMPLETE WARRANTY

Domestic Hot Water & Heat Pump Settings

Menu Code	Function	Default	Site Settings
3011	Domestic Hot water Tank	Use(Hysteresis: Thermo Off)	
3021	Max Temp.	50	
3025	Max. DHW Operation Time	As per Table 1	
3032	Delay Time	As per Table 1	
3042	Interval	TUESDAY	
3043	Start Time	3HOUR	
3044	Target Temp.	55	
3045	Duration	15	
3051	Timer OFF Function	Use	

	#FSV	Tank Volume	Setting
		← 180	50
		200	60
Table 1:	3025 & 3032	230	70
		250	75
		300	90
		→ 400	95

Installer's Signature

Print Name

Heat Pump Installation Checklist

Outdoor Unit Installation

Is the unit installed the correct distance from nearest boundaries?

Is the unit secured correctly to anti-vibration mounts via rubber mounts?

Is the unit mounted plumb level?

Is condensate drain kit fitted? (drain kit located inside HP access door)

If unit is mounted on wall brackets, is drip tray installed?

Heat Pump Plumbing (Outdoor Unit)

Is correct size pipe work used and insulated?

Are flexible anti-vibration hoses fitted and washers used?

Are heat pump isolation valves fitted out at the heat pump?

Is Y-Strainer fitted on the return pipework to heat pump and fitted in the correct orientation?

Is flow and return pipe work connected the right way around?

Cylinder Plumbing (Indoor Unit)

Is the flow sensor correctly installed?

Is Flow and Return pipe work connected the right way around?

Is the heating expansion vessel correctly sized, secured and charged to correct pressure? (Not applicable for Kodiak Compact & Smart Plumb)

Is the Potable expansion vessel secured and charged to the correct pressure?

Are all pump valves and isolating valves fully open?

Has system been completely flushed of air and charged to the correct operating pressure of 2 bar?

Are all safety valves and tundish drained through a metal pipe to an appropriate drain point?

Radiator/UFH System

Has all air been removed from emitters?

Have all emitters been balanced correctly?

If UFH is installed, have correct flow rates been set?

If UFH is installed, are all valves on manifolds/pumps fully open?

Heat Pump Wiring (Outdoor Unit)

Is the correct size breaker used for heat pump?

Is an isolation switch installed for the heat pump and mounted on a fixed structure out beside heat pump?

Is the correct size power supply cable used for heat pump?

Are all cable protrusions avoiding condensate tray?

Is the correct communication cable installed and wired into correct terminals?

Cylinder Wiring (Indoor Unit)

Has the correct breaker & power supply cable been selected for the indoor unit?

Is an isolation switch installed for the indoor unit and is it mounted on a fixed structure beside the unit?

Is the correct communication cable installed and wired into correct terminals?

Is the flow-sensor wired back into correct terminal on control panel?
(Not applicable for Kodiak Compact & Smart Plumb)

Heating Controls/Stats Wiring

Is each zone/floor corresponding with the correct zone valve?

Are all heating controls powered from controller on cylinder?

Are all heating controls wired and working?

Table Of Contents

Outdoor Unit

Pre-Installation Notes.....	8
Main components.....	9
First Fix Notes.....	10
Locating The Outdoor Unit.....	12
Installing The Unit	15
Condensate Management	18
Outdoor Unit Pipe Work	20
Piping Work	21
Electrical.....	23

Indoor Units

Product specifications	25
Pipe work	26

Smart Plumb Cylinder

Smart Plumb Cylinder.....	28
Transporting the unit	29
Installing the unit.....	30
Electrical.....	31
Temperature & Pressure Relief Valve	36
Heating System Connection	37

Potable Pipework.....	38
Commissioning	39

Kodiak Compact

Kodiak Compact.....	40
Transporting the unit	41
Installing the unit.....	42
Electrical.....	43
Temperature & Pressure Relief Valve	46
Heating System Connection.....	48
Potable Pipework.....	49
Commissioning	50

Samsung Controller

Samsung Controller	52
--------------------------	----

Detailed Schematics

Smart Plumb Pre-plumbed Mechanical	58
Smart Plumb Pre-plumbed Electrical	59
Kodiak Compact Mechanical.....	60
Kodiak Compact Electrical	61
Unplumbed Installation Mechanical	62
Unplumbed Installation Electrical	63

Field Setting Parameters

Field Setting Parameters	64
--------------------------------	----

Miscellaneous

Fault Codes.....	65
Troubleshooting	68
Control Kit EHS Mono-block Wiring	69
Commissioning, Service & Maintenance Package	70
Service to Validate Warranty	71
Warranty.....	73
ERP Information	77

Pre-Installation Notes

Store the manual in a safe place in order to be able to use it as reference after installation. For maximum safety installers should always carefully read the following warnings.

Store the provided manual in a safe location with the end user after installation, and remember to hand it over to the new end user if the Heat Pump & Cylinder unit is sold or transferred.

The Air to Water Heat Pump is compliant with the requirements of the Low Voltage Directive (2006/95/EC), the EMC Directive (2004/108/EC) and the pressure equipment directive (97/23/EC).

The manufacturers shall not be responsible for damage originating from unauthorised changes or the improper connection of electric and hydraulic lines.

Do not use units if you see some damages on the units and recognise something untoward such as loud noise, smell or burning.

In order to prevent electric shocks, fires or injuries, always stop the unit, disable the protection switch and contact Joule's technical support if the unit produces smoke, if the power cable is hot or damaged, or if the unit is very noisy.

Always remember to inspect the unit, electric connections, refrigerant tubes and protections regularly. These operations shall be performed by qualified personnel only.

The unit contains moving parts and electrical parts which should always be kept out of the reach of children.

Do not attempt to repair, move, alter or reinstall the unit by unauthorised personnel. These operations may cause product damage, electric shock and fires.

Do not place containers with liquids or other objects on the unit.

All the materials used for the manufacture and packaging of the air to water heat pump are recyclable. The packaging material and exhaust batteries of the remote controller (optional) must be disposed of in accordance with local regulations.

The Air to Water Heat Pump containing a refrigerant must be disposed in an authorised centre or returned to retailer as special wastes.

Wear protective gloves to unpack, move, install, and service the unit to avoid your hands being injured by the edge of the parts. Do not touch the internal parts (water pipes, refrigerant pipes, heat exchangers, etc) while running the units. If you need to adjust and touch the units, allow sufficient time for the unit to cool and be sure to wear protective gloves.

In case of refrigerant leakage, try to avoid contact with the refrigerant because this could result in severe wounds.



NO Pre Paid Meters are to be installed on a Samsung Air Source Heat Pump System

Main components

Dimensions (Overall)

(Unit : mm)

HHSM-G600005-1

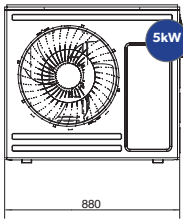
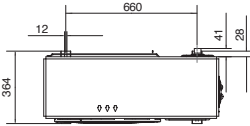

HHSM-G600008-1

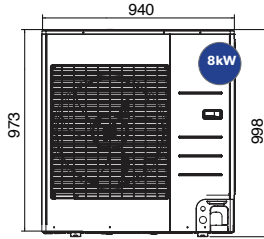
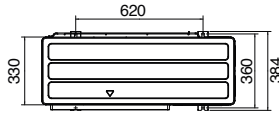

HHSM-G600012-1
HHSM-G600016-1

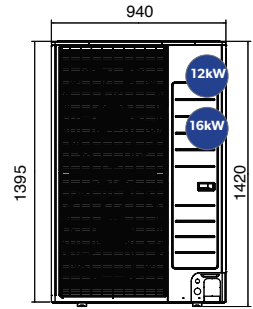

Dimensions (Water pipe)

(Unit : mm)

HHSM-G600005-1

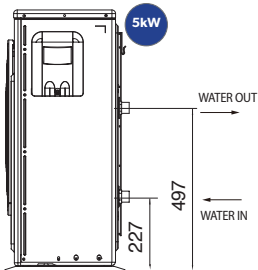

HHSM-G600008-1

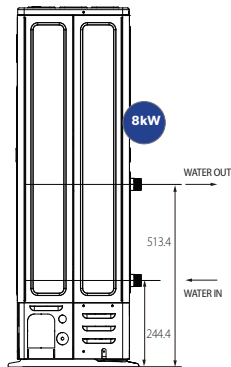

HHSM-G600012-1
HHSM-G600016-1

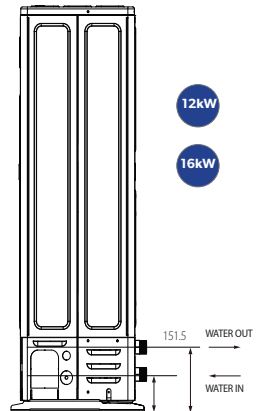

First Fix Notes

Primary Pipework From Outdoor Unit To Indoor Cylinder

- **Minimum** pipe size 28mm copper or 32mm Multilayer
- Outdoor pipework should be fully insulated and protected from water and moisture.
- If outdoor pipework is required use Joule outdoor low energy loss pipework (supplied by the meter).
- The supplied flexible hoses must be fitted directly to the heat pump.

Electrical Supply And Cable Requirements

- Screened 0.75mm 2 core cable from outdoor unit to the indoor units MIM casing.
- Screened 0.75mm 2 core cable from the indoor units MIM casing to samsung controller.
- Power supply to outdoor unit to be terminated with IP67 isolator located next to the unit.
- Power supply to indoor unit (MIM casing) to be terminated via an isolation switch.
- Power supply to the MIM units must connect via the ELCB fitted inside of the MIM unit.

Outdoor Unit	Breaker Size
HHSM-G600005-1	16Amp
HHSM-G600008-1	22Amp
HHSM-G600012-1	28Amp
HHSM-G600016-1	32 Amp

Indoor Unit	Breaker Size
MIM-E03(CN/DN)	20Amp

No. of Cores	Location
2 Core Screened	From indoor unit to outdoor unit. F1 & F2 Comms.
2 Core + Earth	From Zone 1 stat or Under-floor heating control centre to Indoor unit.
2 Core + Earth	From Zone 2 stat or Under-floor heating control centre to indoor unit.
2 Core Screened	From MIM unit to Samsung controller.

- When installing the outdoor unit take great care to install as per the detailed notes for installation locations. The Air-to-Water Heat Pump must have minimum clearance of 300mm at the rear of the unit and 1500mm at the front of the unit.
- The Air-to-Water Heat Pump must not be installed in a location without these clearances available.
- Condensation will form on the Air-to-Water Heat Pump. Ensure adequate provisions are put in place to prevent water forming on the ground beneath the Air-to-Water Heat Pump, resulting in a potential Health and Safety hazard.
- The Air-to-Water Heat Pump must be installed vertically and should not be tilted at an angle.
- A primary circulation pump must be installed on the flow pipework and a secondary circulation pump must be installed on the return pipework back to the Air-to-Water Heat Pump to ensure that minimum flow rates will be achieved (as per installation schematics). Installing a single circulation pump will not guarantee the correct flow rate. Unless using a Smart plumb cylinder or Low loss header/Buffer vessel.

First Fix Notes

- Site visits to solve a flow rate issue due to the installation of a single pump on the pipework are not covered under EUW and as such will incur a call-out charge.
- Underfloor heating pipe centres to be equal to or less than 150mm.
- Radiators are to be sized according to standardized design methods. Eg. SR.50 or MCS.
- No mixing sets to be used on the underfloor heating manifolds with the exception when a back up heater/boiler is installed.
- All underfloor heating manifolds and radiator zones must have an individual pump to help circulate and maintain flow rate.
- All zones to be controlled using 2 port valves (22mm on heating zones and 28mm on hot water zone).
- 3 port valves MUST not be used.
- Mechanical by-pass valve to be installed after the primary circulating pump on the flow pipe but before any heating zone valves (Not applicable for Kodiak Compact & Smart Plumb).
- All underfloor heating circuits to be controlled from the run signal from the third party underfloor wiring centre.
- All radiator zones to be controlled from 3rd party time clock and Thermostat; as per local building regulations.
- The hot water control is managed through the Samsung controller. Hot water takes priority over heating above 0°C.
- End user interacts with 3rd party controls only. It is the installers responsibility to ensure that attached designs are followed to achieve this or if a uniquely designed system is being installed the designer must allow for the 3rd party controls facility.
- Underfloor heating circuits are controlled by 3rd party room thermostats.
- Use of time clocks to turn off underfloor heating circuits is not recommended.
- Room thermostats in underfloor heating circuits should not be turned off but set back to a lower temperature using appropriate heating setback control for periods of unoccupied use.
- The flow sensor must be installed as per the diagram on page 27.
- Air is the most prevalent cause of restricted flow in the system. Make sure that all pipework can easily be purged of air and that all air is removed from the system prior to starting the unit. Site visits to solve a flow rate issue due to the presence of air are not covered under EUW and as such will incur a call-out charge.

Locating The Outdoor Unit

Moving the outdoor unit

- Select the moving route in advance.
- Be sure that moving route is safe from weight of the outdoor unit.
- Do not slant the product more than 30° when carrying it. (do not lay the product down sideways)
- The surface of the heat exchanger is sharp. Be careful not to be injured while moving and installing.

Moving the outdoor unit by wire rope

Fasten the outdoor unit by two 8m or longer wire ropes as shown at the figure. To prevent from damage or scratches, insert a piece of cloth between the outdoor unit and rope, then move the unit.

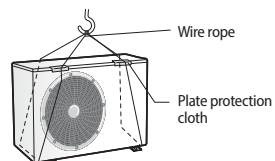

Moving the outdoor unit with a fork lift

Insert the fork into the wooden pallet at the bottom of the outdoor unit carefully. Be careful that the fork does not damage the outdoor unit.

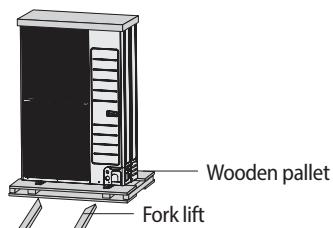

Deciding on where to install the outdoor unit

Decide the installation location regarding the following condition and obtain the user's approval.

- The outdoor unit must not be placed on its side or upside down, as the compressor lubrication oil will run into the cooling circuit and seriously damage the unit.
- Choose a location that is dry and sunny, but not exposed to direct sunlight or strong winds.
- Do not block any passageways or thoroughfares.
- Choose a location where the noise of the Air to Water Heat Pump when running and the discharged air do not disturb any neighbours.
- Choose a position that enables the pipes and cables to be easily connected to the other hydraulic system.
- Install the outdoor unit on a flat, stable surface that can support its weight and does not generate any unnecessary noise and vibration.
- Position the outdoor unit so that the air flow directly stream towards the open area.
- Place the outdoor unit where there are no plants and animals because they may cause malfunction of outdoor unit.
- Maintain sufficient clearance around the outdoor unit, especially from a radio, computer, stereo system, etc.

Locating The Outdoor Unit

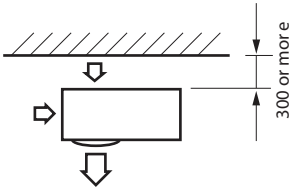

When the air outlet is opposite the wall.

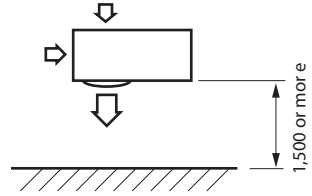

When the air outlet is towards the wall.

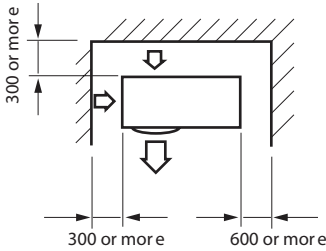

When 3 sides of the outdoor unit are blocked by the wall.

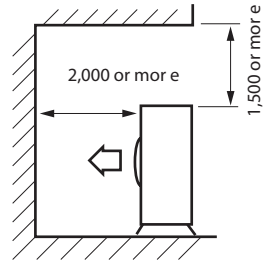

The upper part of the outdoor unit and the air outlet is towards the wall.

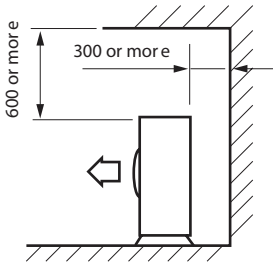

The upper part of the outdoor unit and the air outlet is opposite the wall.

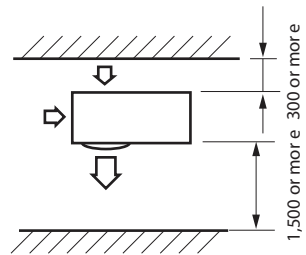

When front and rear side of the outdoor unit is towards the wall.

Locating The Outdoor Unit

When Installing More Than 1 Outdoor Unit

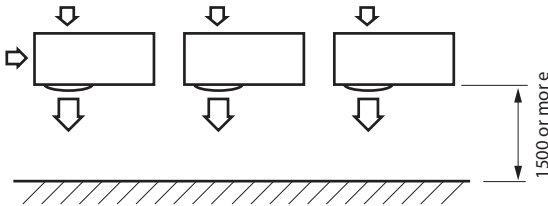

When the air outlet is toward the wall.

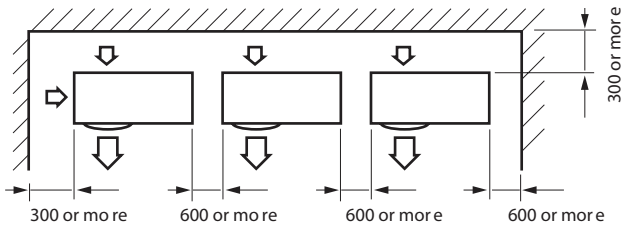

When 3 sides of the outdoor unit are blocked by the wall.

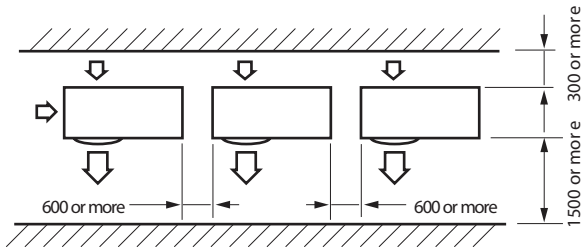

When front and rear side of the outdoor unit is towards the wall.

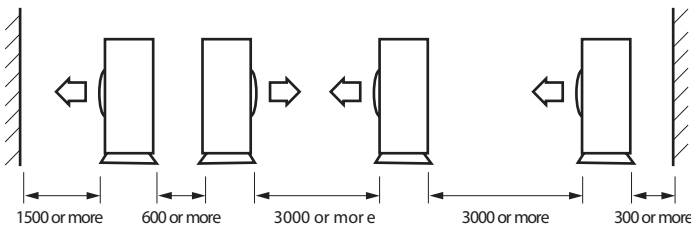

The upper part of the outdoor unit and the air outlet is opposite the wall.

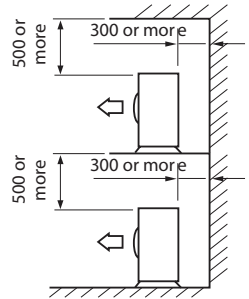

When front and rear side of the outdoor unit is towards the wall.



The units must be installed according to distances declared, in order to permit accessibility from each side, either to guarantee correct operation of maintenance or repairing products. The unit's parts must be reachable and removable completely under safety condition.

Installing The Unit

Installation Guidelines



Make sure to follow below guides when installing at the seashore.

1. Do not install the product in a place where it is directly exposed to sea water and sea breeze.
 - Make sure to install the product behind a structure (such as building) that can block sea breeze
 - Even when it is inevitable to install the product in seashore, make sure that product is not directly exposed to sea breeze by installing a protection wall.
2. Consider that the salinity particles clinging to the external panels should be sufficiently washed out.
3. Because the residual water at the bottom of the outdoor unit significantly promotes corrosion, make sure that the slope does not disturb drainage.
 - Keep the floor level so that rain does not accumulate.
 - Be careful not to block the drain hole due to foreign substance
4. When product is installed in seashore, periodically clean it with water to remove attached salinity.
5. Make sure to install the product in a place that provides smooth water drainage. Especially, ensure that the base part has good drainage.
6. If the product is damaged during the installation or maintenance, make sure to repair it.
7. Check the condition of the product periodically.
8. All R32 models have a hydrophobic 'bluefin' coating as standard.
9. The Outdoor unit must be checked 1 year after installation for signs of corrosion, regardless of the installation location.

If installed within 500m of the seashore, an anti-corrosion coating is recommended with *retreating effected areas every 2 years.

If installed within 500m~2km of the seashore, an anti-corrosion coating is optional. If coated, it is recommended the unit is *retreated every 4 years. If not coated, it is recommended the unit is *retreated every 2 years.

***Note:** Retreating is an essential part of the Outdoor units annual service plan.



Depending on the condition of power supply, unstable power or voltage may cause malfunction of the parts or control system. (Places using power supply from electric generator, etc).

Do not install the Air to Water Heat Pump in following places

1. The place where there is mineral oil or arsenic acid. There is a chance that parts may get damaged due to burned resin.
2. The capacity of the heat exchanger may reduce or the Air to Water Heat pump may be out of order.
3. The place where corrosive gas such as sulfurous acid gas generates from the vent pipe or air outlet. The

copper pipe or connection pipe may corrode and refrigerant may leak.

4. The place where there is a danger of existing combustible gas, carbon fiber or flammable dust. The place where thinner or gasoline is handled.
 - If the outdoor unit is installed at a height, ensure that its base is firmly fixed in position.
 - Make sure that the water dripping from the drain hose runs away correctly and safely.
 - Installation must be carried out by qualified personnel for handling the refrigerant. Additionally, reference the regulations and laws.
 - Be careful not to let foreign substances (lubricating oil, refrigerant other than R-32, water, etc.) enter the pipings.
 - For disposal of the product, follow the local laws and regulations.
 - For installation with handling the refrigerant(R-32), use dedicated tools and piping materials.
 - Do not install where there is a risk of combustible gas leakage.

Outdoor Unit Installation

The outdoor unit must be installed on a rigid and stable base to avoid any increase in the noise level and vibration. Particularly if the outdoor unit is to be installed in a location exposed to strong winds or at a height, the unit must be fixed to an appropriate support (wall or ground).

Fix The Outdoor Unit With Anchor

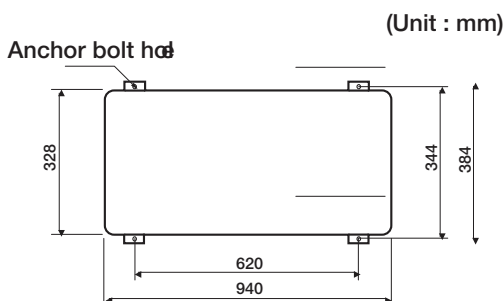

The anchor bolt must be 20mm or higher from the base



Condensate drain plug and anchor bolt rubber grommets come in a bag inside the door of the outdoor unit

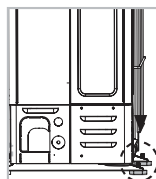
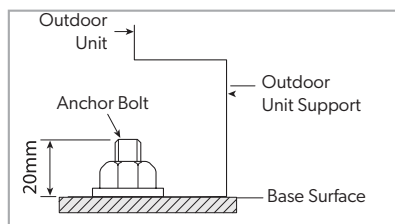

Designed to cut off residual vibration from outdoor unit to rack. (not supplied with product)

Outdoor Unit Support (Ground)

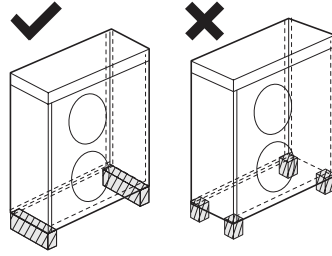

Outdoor Unit Support (Wall)

- Ensure the wall will be able to suspend the weight of rack and outdoor unit.
- Install the rack close to the column as much as possible.
- Install proper grommet in order to reduce noise and residual vibration transferred by outdoor unit towards wall.

Selecting A Location In Cold Climate



When operating the unit in a low outdoor ambient temperature, be sure to follow the instructions described below.

- To prevent exposure to wind, install the unit with its suction side facing the wall.
 - Never install the unit at a site where the suction side may be exposed directly to wind.
 - To prevent exposure to wind, install a baffle plate on the air discharge side of the unit.
 - In heavy snowfall areas it is very important to select an installation site where the snow will not affect the unit. If lateral snowfall is possible, make sure that the heat exchanger coil is not affected by the snow (if necessary construct a lateral canopy).
1. Construct a large canopy.
 2. Construct a pedestal. Install the unit high enough off the ground to prevent it being buried under snow.

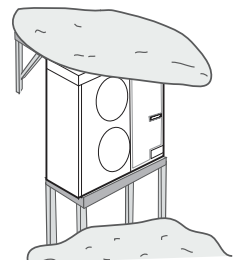

Condensate Management

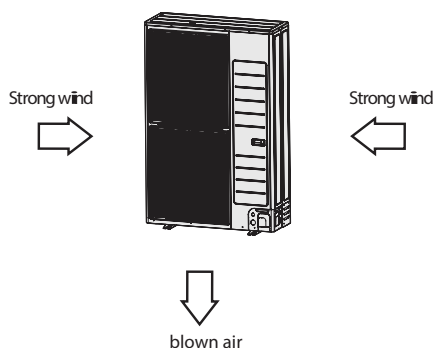

When installing the outdoor unit, consider the direction of any strong wind. Strong wind can overturn the outdoor unit. If possible, position the unit so the wind direction is towards the side of the unit.

When the Air to Water Heat Pump is running in heating mode, ice can begin accumulate on the surface of the condenser.

To prevent ice from growing, the Heat Pump will go into defrost mode to melt the ice.

The water formed from the melted ice will fall to the base of the heat pump where it can escape to ground through the drain holes in the base. This will require a drain pit or soak hole beneath the Heat Pump to prevent water or ice from forming on the ground around the Heat Pump which may be a safety hazard.

If installing the Heat Pump on a wall, the supplied drain plug and drain hose can be fitted to pipe the water away to drain.

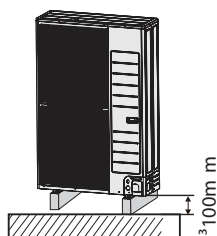

If the drain work is not sufficient, it can lead to a reduction of the system performance and possible system damage.

If the unit is not been installed over a gravel trap to allow for drainage then carry out the following steps:

1. Mount the unit on the anti-vibration feet keeping the unit more than 100mm above the ground.
2. Connect the drain plug as shown above and a suitable outlet pipe.
3. Run the pipe into a suitable drain located near by. If there is no drain nearby run the pipe to an area where natural drainage can take place.
4. Never mount the unit on a wall frame without installing sufficient drainage management.

Condensate Management

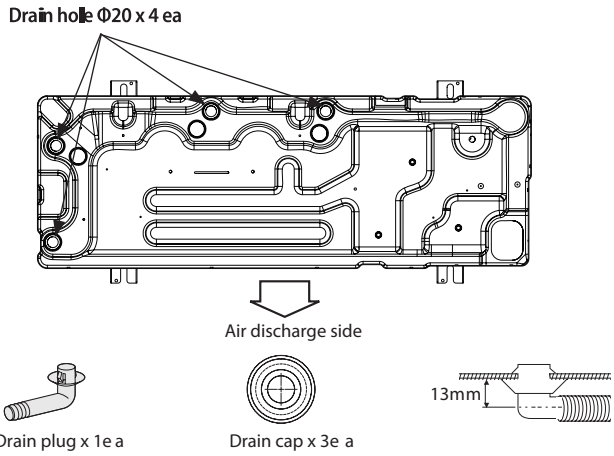

1. Prepare a water drainage channel around the foundation, to drain waste water from around the unit.
2. If the water drainage of the unit is not easy, please build up the unit on a foundation of concrete blocks, etc. (the height of the foundation should be a maximum of 150mm).
3. If you install the unit on a frame, please install a water-proof plate within 150mm of the underside of the unit in order to prevent the invasion of water from the lower direction.
4. When installing the unit in a place frequently exposed to snow, pay special attention to elevate the foundation as high as possible.
5. If you install the unit on a building frame, please install a waterproof plate (field supply) within 150mm of the underside of the unit in order to avoid the drain water dripping

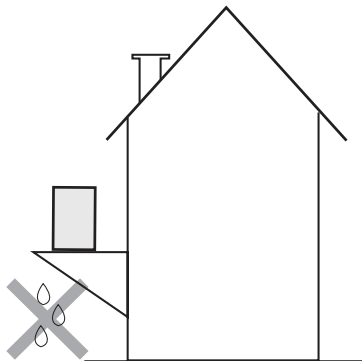

Outdoor Unit Pipe Work

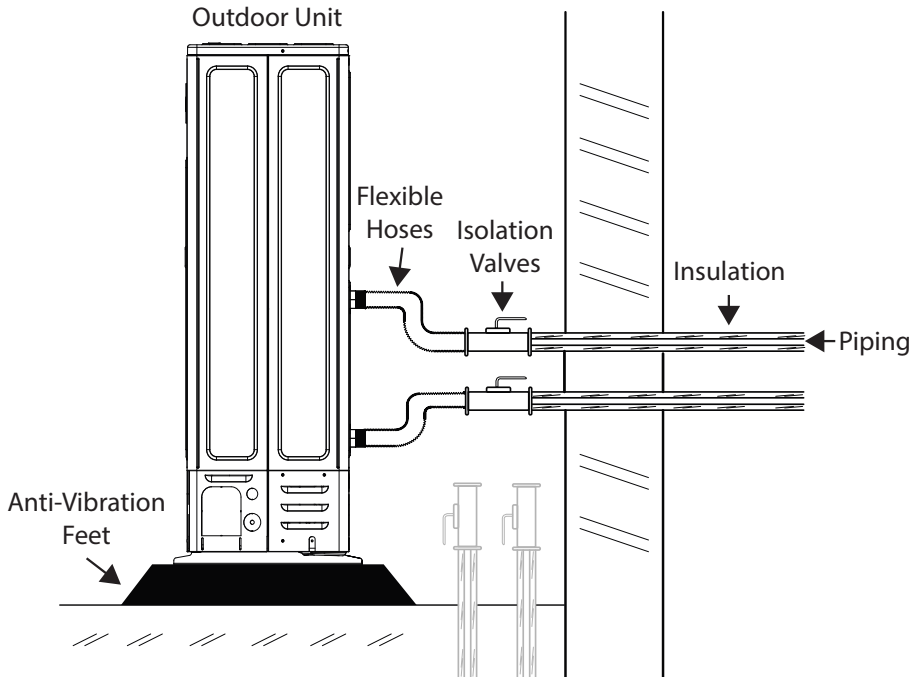

Freeze protection

Freeze protection solutions must use propylene glycol with a toxicity rating of Class 1

Freezing Points of Propylene Glycol - Water Mixtures

Percent Propylene Glycol [wt. %]	Freezing Point [°F]	Freezing Point [°C]
0	32	0
10	26	-3
20	20	-7
30	10	-12
36	0	-18
40	-5	-20
43	-10	-23
48	-20	-29

Piping Work

Setting capacity and pre-pressure of the expansion vessel

When it is required to change the default precharge pressure of the expansion vessel(1 bar), keep in mind the following guidelines:

- Use only dry nitrogen or air to set the expansion vessel pressure.
- Inappropriate setting of the expansion vessel precharge pressure will lead to malfunction of the system.
- Therefore, the pressure should only be adjusted by an competent installer.

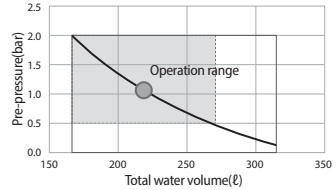

Installation height difference(a)	Water volume	
	< 220 Litres	> 220 Litres
<7m	No precharge pressure adjustment required.	Actions required: <ul style="list-style-type: none"> • Pressure must be decreased, calculate according to "Calculating the pre-pressure of the expansion vessel". • Check if the water volume is lower than maximum allowed water volume.
>7m	Actions required: <ul style="list-style-type: none"> • Precharge pressure must be increased, calculate the appropriate value following by "Calculating the precharge pressure of the expansion vessel". • Check if the water volume is lower than maximum allowed water volume. 	Expansion vessel of the unit too small for the installation.

(a) Installation height difference: height difference(m) between the highest point of the water circuit and the indoor unit. If the unit is located at the highest point of the installation, the installation height is considered 0m.

- When Expansion vessel has a capacity 8 liters and 1bar pre-charged. Water volume of total system for reliable performance is minimum 30 liters.

Calculating the precharge pressure of the expansion vessel

The pre-pressure(Pg) to be set depends on the maximum installation height difference(H) and is calculated as below :

$$Pg=(H/10+0.3) \text{ bar}$$

Piping work

Flow sensor

Supplied with the Pre Plumbed cylinder is a Flow Sensor and a Flow Meter.

The Flow Sensor should be mounted within 2 M of the Control Kit.

This lead can be extended, it is a 4 core cable, if you do extend ensure that the cores are not crossed.

The sensor must be located indoors as it is only splash proof.

Ideally the Flow sensor will be mounted horizontally in the return line to the Outdoor unit.

The minimum straight pipe on inlet and outlet of the flow sensor must be adhered to, as detailed in the diagram

The flow sensor plugs directly onto the MIM unit on Connections CSN 057

- Possibility of bubble formation
- Possibility of drain-off (measuring pipe partly filled)

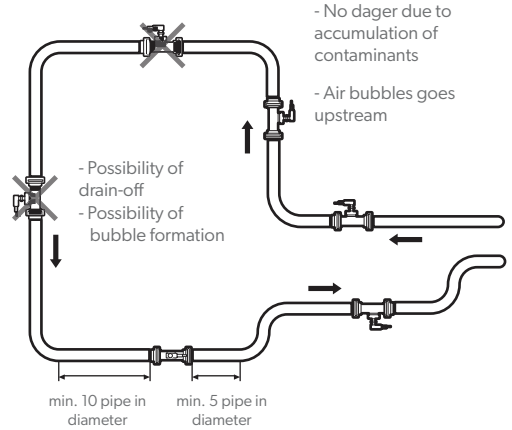

Pressure relief valve

The outdoor unit does not have a pressure relief valve incorporated. The installer **MUST** ensure the system is protected from over-pressurisation. The valve shall prevent abnormal water pressure from damaging the system by opening at a maximum pressure setting of 3.0 bar.

Filter / Strainer

Installation of the filter/ strainer is essential to protect the outdoor unit from system debris.

The filter/ strainer must be cleaned regularly to maintain the minimum system flow rate.

Piping insulation

Pipe or duct insulation should comply with BS 5422:2009. Alternatively, insulation of a thickness that provides reduction of heat loss equivalent to material having a thermal conductivity of 0.035 W/mK at 40 °C and thickness equal to the diameter of the pipe (or 40mm, whichever is smaller) may be used.

Electrical

Power Cable Specifications

1 phase

Outdoor unit	Rated		Voltage Range		MCA	MFA
	Hz	Volts	Min	Max	Min. Circuit Amps.	Max. Fuse Amps.
HHSM-G600005-1	50	220-240	198	264	16 A	20 A
HHSM-G600008-1	50	220-240	198	264	22 A	27.5 A
HHSM-G600012-1	50	220-240	198	264	28 A	35 A
HHSM-G600016-1	50	220-240	198	264	32 A	40 A

- The power cable is not supplied with Air to water heat pump.
- Supply cords of parts of appliances for outdoor use shall not be lighter than polychloroprene sheathed flexible cord (Code designation IEC:60245 IEC 57 / CENELEC:H05RN-F)
- This Equipment complies with IEC 61000-3-12.
- For the power Cable, use the grade H07RN-F or H05RN-F materials.

Communications Cable Specifications

- If there is a risk of disturbance to the communication cable, a screened cable must be used.

Communication cable

0.75mm², 2wires

Outdoor Unit terminal block Specifications

AC power : M5 Screw

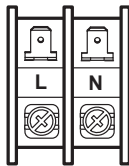

Communication: M4 Screw

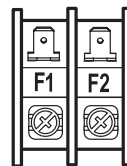

During the unit installation make first the piping connections and then electrical connections. If unit is uninstalled first disconnect electrical cables, then the piping connections.electrical connection.

Electrical

Wiring diagram of power cable

When using ELB/
MCCB for 1 phase

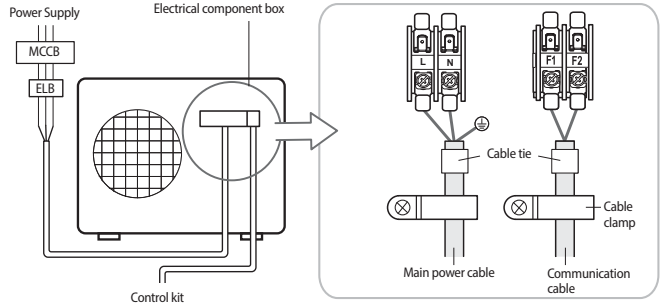

CAUTION!

- You should connect the power cable into the power cable terminal and fasten it with a clamp.
- To protect the product from water and possible shock, you should keep the power cable and the connection cord of the control kit and outdoor units within ducts. (with appropriate IP rating and material selection for your application)
- Ensure that main supply connection is made through a switch that disconnects all poles, with contact gap of at least 3 mm.
- Devices disconnected from the power supply should be completely disconnected in the condition of overvoltage category.
- Keep distances of 50mm or more between power cable and communication cable.

Wiring diagram of communication cable

1 phase

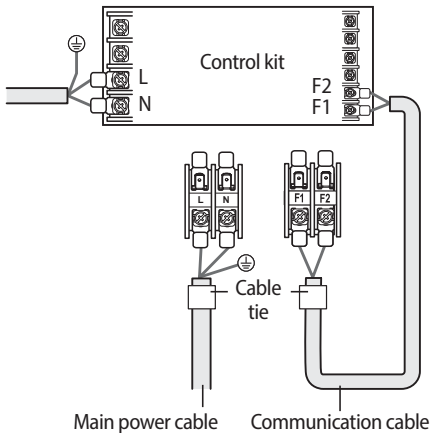

Product specifications

Product compatibility



HHSM-G600005-1	HHSM-G600008-1	HHSM-G600012-1	HHSM-G600016-1
----------------	----------------	----------------	----------------

	Capacity	5kW	8kW	12kW	16kW
	Kodiak Compact				
HUKC-G6210C-3C	210L COMPACT	■	■	■	■
	Smartplumb				
HUGH-G61860-3C	SMARTPLUMB 180/60L	■	■	■	
HUGH-G62060-3C	SMARTPLUMB 200/60L	■	■	■	■
HUGH-G62590-3C	SMARTPLUMB 250/90L		■	■	■
HUGH-G64013-3C	SMARTPLUMB 300/130L		■	■	■
HUGH-G64013-3C	SMARTPLUMB 400/130L			■	■

Pipe work

SmartPlumb Pipework

Reference	Description
A	H.P Flow
B	H.P Return
C	Heating Return
D	Heating Flow Zone 1
E	Heating Flow Zone 2
G	Heating Expansion Vessel Connection
H	Heating Safety Valve Outlet
I	Hot Outlet
J	Cold Inlet
K	Balanced Cold Water
L	Potable Expansion Vessel Connection
M	Secondary Return Connection
N	Tundish

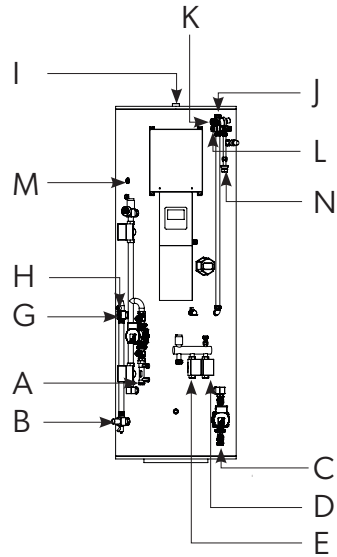

Upon filling and commissioning, ensure all connections are completely watertight.

Pipe work

Kodiak Compact Pipework

Reference	Description	Value
A	Heat Pump Flow	1 inch BSP
B	Heating Zone 3	3/4 inch BSP
C	Heating Zone 2	3/4 inch BSP
D	Heating Zone 1	3/4 inch BSP
E	Hot Outlet	3/4 inch BSP
F	Cold Inlet	3/4 inch BSP
G	System Return	1 inch BSP
H	Heat Pump Return	1 inch BSP

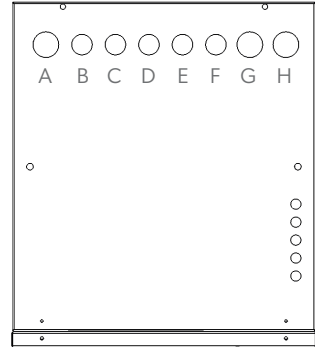

All the pipework connections are off the top section of the casing. Upon filling and commissioning, ensure all connections are completely watertight.

Smart Plumb Cylinder

Product Schematics

	180L/60L	200L/60L	250L/90L	300L/130L	400L/130L
A	1870	1980	1950	1850	2160
B	540	540	600	710	710
C	120				

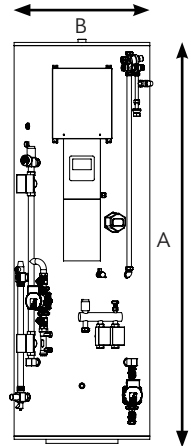

Left Side View

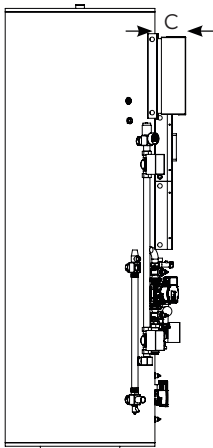

Front View

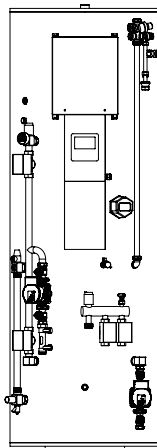

Right Side View

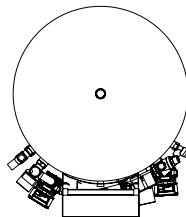
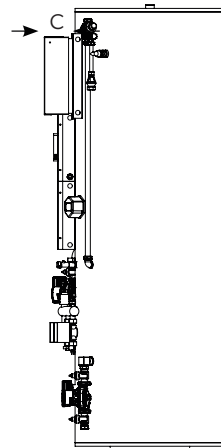

Top View

Transporting the unit

Transport and Handling

The Smart Plumb unit is delivered fully packaged and fixed to a wooden pallet base. Care should be taken when transporting the cylinder unit ensuring that the casing is not damaged by impact.

At least two people should lift the cylinder to prevent injuries. The cylinder must be stored in a dry area and must never be dropped during handling. Packaging should only be removed at the installation location. This will help protect the structure and the components. The cylinder must be installed on a level floor with the required load bearing capability.

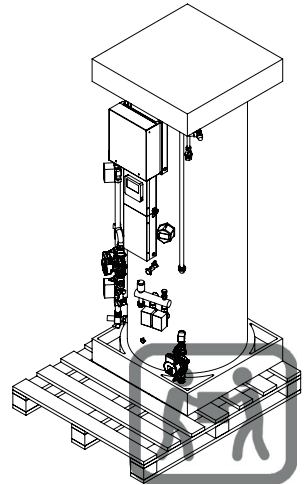

The cylinder unit must be transported in an upright position only.

Suitable Location

Care should be taken that there is a minimum distance in front of the unit for service and maintenance works to be carried out. Enough access to allow maintenance of the valves should be considered. In addition, the immersion heater is 400mm in length and this distance should be considered to allow withdrawal for servicing if required.

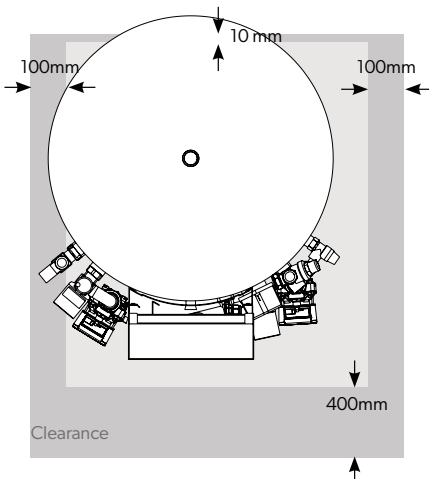

Install the cylinder unit where it is not exposed to water/excessive moisture. Particular attention is needed if sitting in a garage or outbuilding as the unit should be protected from frost. All exposed pipework must be insulated. The unit must be installed upright on a base capable of supporting its weight when full (please see the technical specification section for weights).

Installing the unit

Moving the Indoor unit

- Select the moving route in advance.
- Be sure that moving route is safe from weight of the cylinder.

Moving the Indoor unit with a fork lift.

- Insert the fork into the wooden pallet at the bottom of the cylinder carefully. Be careful that the fork does not damage the indoor unit.
- When moving the cylinder, be careful to not damage the cylinder by impact. Do not remove the packaging until cylinder has reached its final installation location.

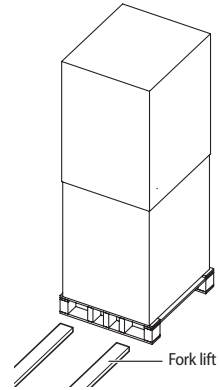

Installation space

- Ensure to leave the appropriate space as indicated in the drawing.
- Adhering to the installation space guidelines will ensure adequate ventilation so that the components of indoor unit will not be damaged from overheating.

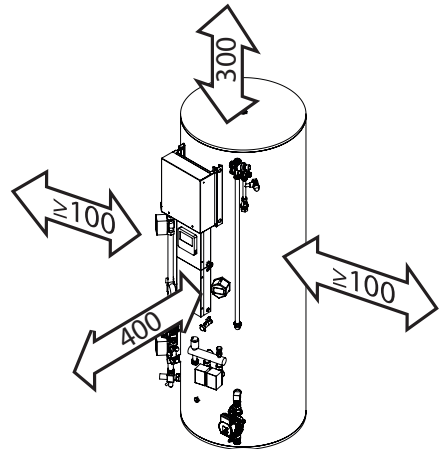

Electrical

System Overview

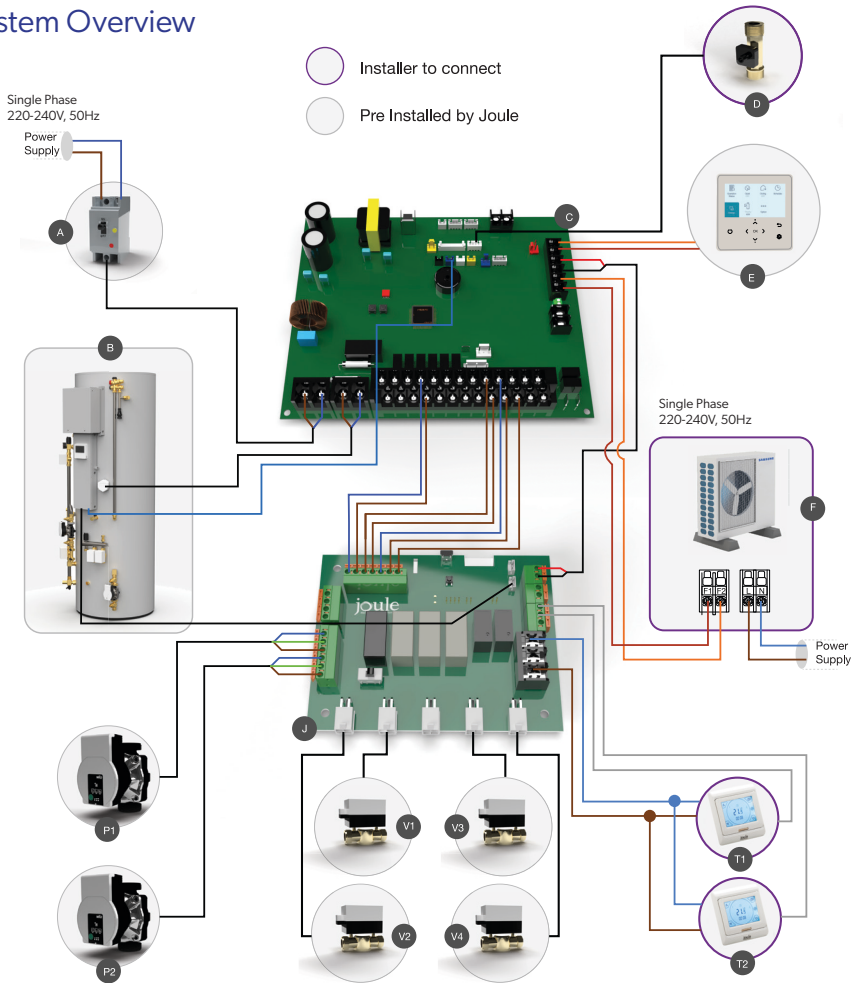

For simplicity Earth connections have not been shown.

	Description	Item Codes		Description	Item Codes
A	Samsung 30A ELCB	HZC-0000A25-70	P1	Wilo Primary Circulating Pump	HZC-0000A25-60
B	SmartPlumb Tank	HUGH-G6x0x0-xC	P2	Wilo Secondary Circulating Pump	HZC-0000A25-60
C	Samsung MIM-E03CN/DN	HZC-0000A25-70	T	Joule E91 room thermostat	UZS-E91-TS0230
D	Samsung Flow Sensor	HZC-0000A25-70	V1	DHW - 2 Port Zone Valve	TZM-I-E00028MM
E	Samsung Touchscreen Controller	HZC-0000A25-70	V2	Buffer - 2 Port Zone Valve	TZM-I-E00028MM
F	Samsung Outdoor Unit	HHSM-G6000xx-1	V3	Heating Valve 2 - 2 Port Zone Valve	TZM-I-E00022MM
J	Joule Kodiak PCB	TZ-W-0000000W	V4	Heating Valve 1 - 2 Port Zone Valve	TZM-I-E00022MM

Electrical

SmartPlumb Power Supply

The table below outlines the power requirements for the SmartPlumb Pre-Plumb tank (MIM-E03(CN/DN))

Indoor Unit	Load	Power Supply	Power Cable	MAX. Length	Type GL
			mm ² wires	m	A
MIM-E03(CN/DN)	1 Booster Heater (3kw)	1Ø, 220-	4.0 / 3	<10m	20
			6.0 / 3	10m<L20m	20
	Booster Heater (~3kw) + Backup Heater (~3kw)	240Vac, 50Hz	6.0 / 3	<10m	40
			8.0 / 3	10m<L20m	40

1) This is the standard setup in a SmartPlumb Pre-Plumb tank.

Power Supply Cable Entry

All electrical wiring must be carried out by a competent installer and be installed in accordance with current local Wiring Regulations.

The cable entry point can be seen the diagram on the right. Remove the bottom vanity panel to access the cable fixing points and ensure all cables are secured using the fixings provided.

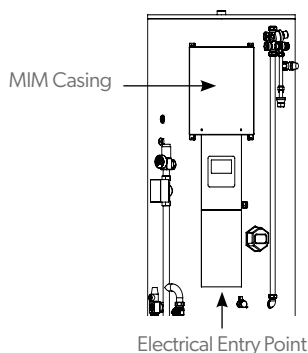

Power Supply Connections

Connect 'Live' and 'Neutral' power line with the terminals marked 'L, N' of the ELCB which is located inside the MIM casing.

Connect the 'Protective Earth' line with the 'Earth screw' inside the MIM casing. The rear casing of the MIM is the termination point for all Protective Earth Connections. Please use earth termination points provided.

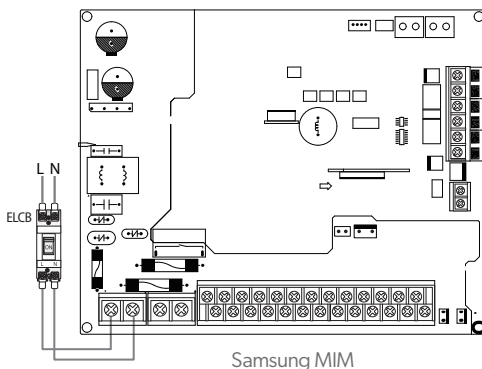

Electrical

Protective Earth

All pre-installed components are earthed. The integrity of a protective earth system relies on its primary connection. It is the installers responsibility to ensure the rear of the MIM casing is earthed, therefore providing a protective earth connection to all system components.

Connecting the communication cable

The communication cable carries the signal between the outdoor unit and the MIM casing.

Using a two-core cable connect the terminals F1 & F2 of the outdoor unit to the terminals F1 & F2 of the MIM casing.

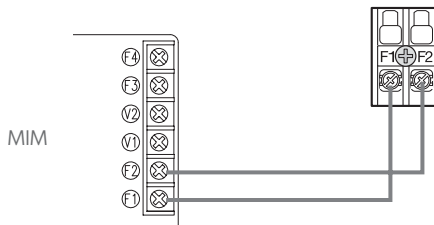

Connecting the flow sensor

The flow sensor is a 4 pin push fit connector that connects to the MIM casing on the connection labelled 'CNS057'.

The flow sensor cable is 2 meters in length. This can be extended however it is essential that the inner cable core colours are matched end to end.

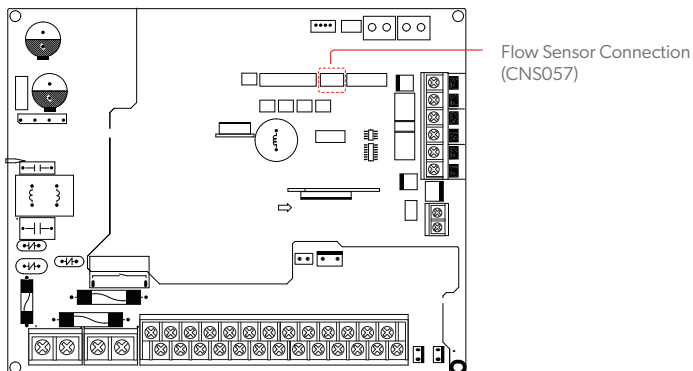

Electrical

Connecting External Controls

Connection of external controls to the Smart Plumb unit are made directly to the 'Joule Kodiak PCB' which is located behind the top vanity panel, as detailed in the image shown on the right.

There is a dedicated 230V AC supply to power the external controls. These terminals are labelled 'External Controls Power', specifically

'L, N & E' on the 'Joule Kodiak PCB'.

The switched live input from the external controls should be connected to the terminals labelled 'Zone 1' S/L, 'Zone 2' S/L and 'Zone 3' S/L on the 'Joule Kodiak PCB', as detailed in the image below.

N.B. Applying a 230V switched live to the terminal 'Zone 1' S/L will activate 'Heating Zone Valve 1'.

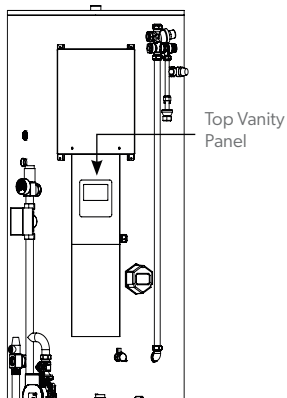

WARNING!
All external controls are 230V AC Connections

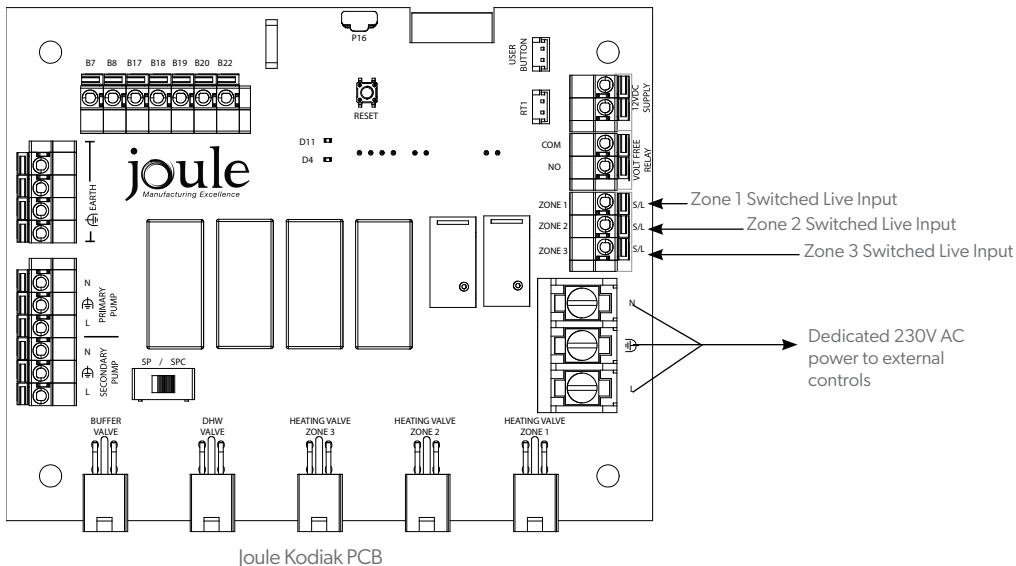

Electrical

Example External Controls

The schematic below shows examples of different types of external controls and how they connect to the 'Joule Kodiak PCB'.

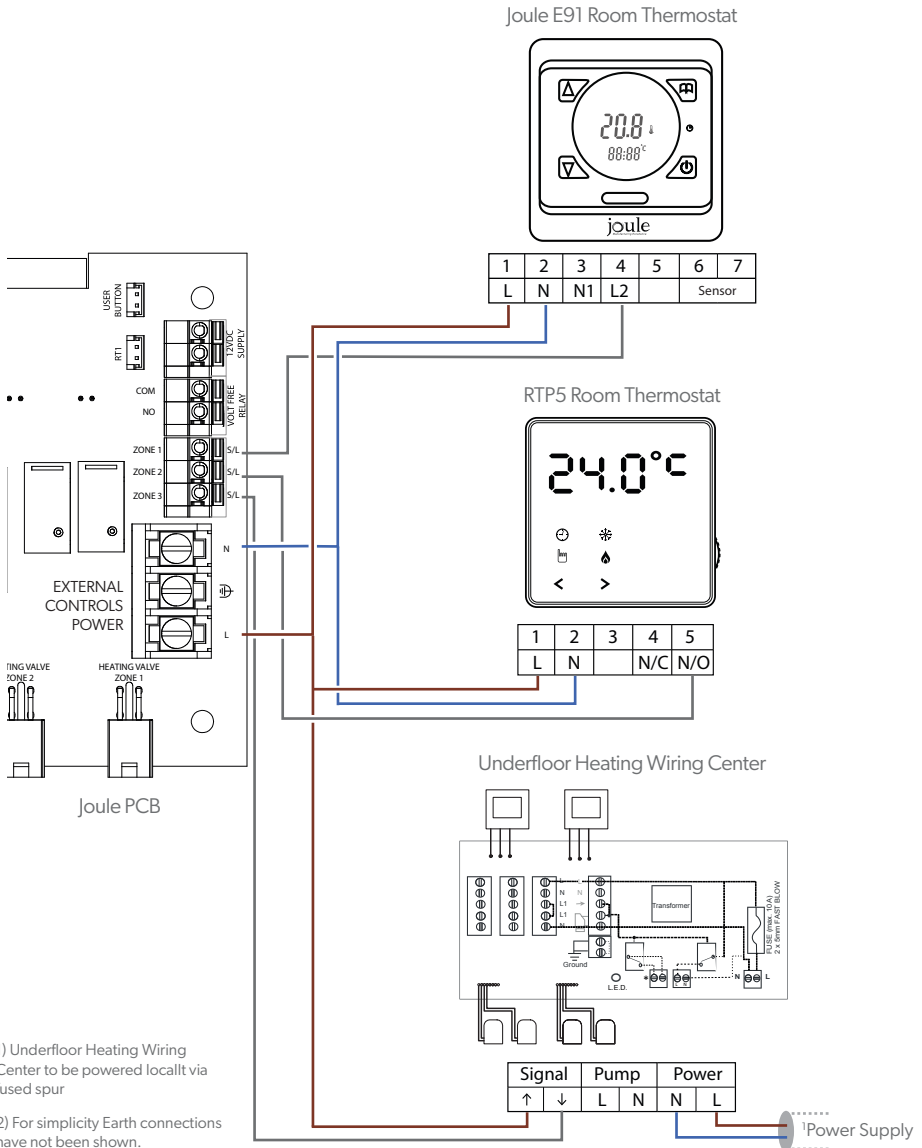

Temperature & Pressure Relief Valve

Connect the tundish and route the discharge pipe which must be routed in accordance with Building Regulations - Part G3 of schedule 1.

When operating normally water will not be discharged from the temperature and pressure relief valve. Water discharge from the temperature and pressure valve will only occur under fault conditions. The tundish is pre-fitted as shown below.

The discharge pipe (D2) coming from the tundish should terminate in a safe place where there is no risk to persons near the discharge, be of metal and:

- Be at least one pipe size larger than the nominal outlet size of the safety device unless its total equivalent hydraulic resistance exceeds that of a straight pipe 9m long, i.e. discharge pipes between 9m and 18m equivalent resistance length should be at least two sizes larger than the nominal outlet size of the safety device, between 18 and 27m at least 3 sizes larger, and so on.
- Bends must be taken into account in calculating the flow resistance. Refer to Table 1 and the worked example. An alternative approach for sizing discharge pipes would be to follow BS6700 Specification for design, installation, testing and maintenance of services supplying water for domestic use within buildings and their curtilages.
- Be installed with a continuous fall. The discharge must be visible at the final point of discharge.

TABLE 1

	G1/2			G3/4			G1		
Min. size of discharge pipe D1	15mm			22mm			28mm		
Min. size of discharge pipework D2 from tundish	22mm	28mm	35mm	28mm	35mm	42mm	35mm	42mm	54mm
Max. length of straight pipe (no bends or elbows)	Up to 9m	Up to 18m	Up to 27m	Up to 9m	Up to 18m	Up to 27m	Up to 9m	Up to 18m	Up to 27m
Deducts the below from the maximum length for each bend or elbow in the discharge pipe	0.8m	1m	1.4m	1.0m	1.4m	1.7m	1.4m	1.7m	2.3m

Sizing of copper discharge pipe (D2) for a temp, relief valve with a G1/2 outlet size (as supplied)

Example of Discharge Arrangements

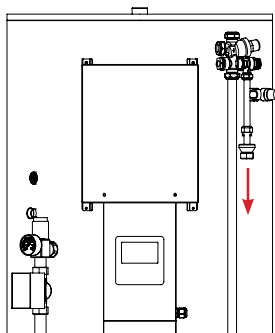

Heating System Connection

Connecting To The Cylinder

If plastic pipes are used, they must be approved temperature resistant to 95°C at a pressure of 10 bar. A thermostatic mixer should be installed in the system to prevent the risk of scalding.

Heat Pump Primary Connections

Connect the primary connections as shown below. In the Smart Plumb the primary circulating pump is pre-fitted along with the hot water motorised valve.

Heating System Pipe Connections

Connect the heating zone connections as shown below. In the Smart plumb the heating zone motorised valves are pre-installed. The circulating pump for the heating system is also pre-installed.

All heating zone returns should be joined at the cylinder and return via heating return as shown below.

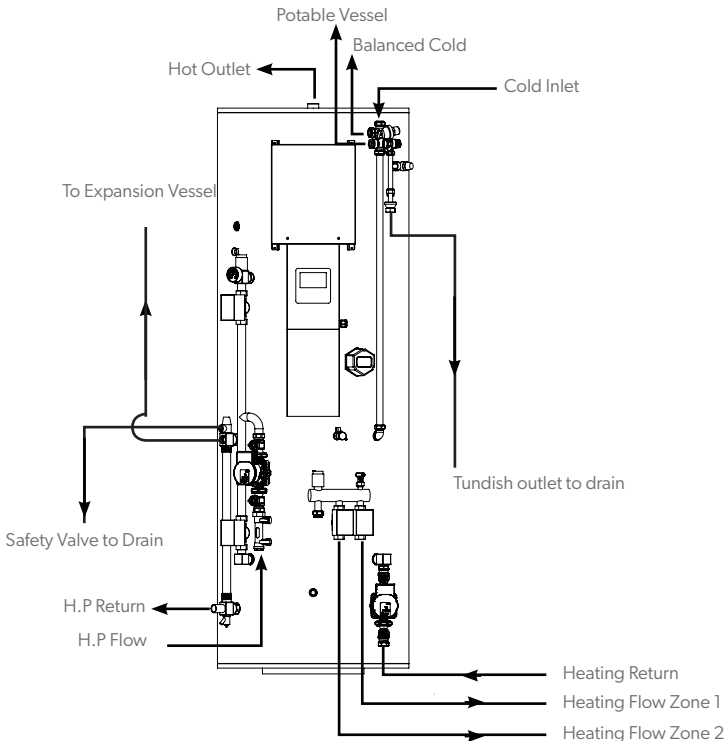

Potable Pipework

Fitting the Inlet Control Group

Excess pressure can lead to the cylinder bursting. The inlet control set supplied has an expansion relief valve with a 15mm connection to allow it to be connected to a tundish, this is pre-plumbed. Make sure that there is enough space for future maintenance and for connection of the discharge pipe for the expansion relief valve. It is essential that this connection is not covered or closed.

The cold inlet must be piped into the top of the inlet control group. It is recommended to install a full bore isolation valve on the cold inlet for maintenance and servicing of the valve.

The water supply should be checked to ensure it can meet these requirements. If necessary, consult the local water authority regarding the likely pressure and flow rate availability. Consideration should be given to upgrading existing 1/2" (15mm) cold mains pipework to a larger size if the recommended minimum pressure / flow rate is not being achieved. Joule™ recommend that primary pipework used has a minimum diameter of 22mm to ensure low pressure loss.

Potable Expansion Vessel

The expansion vessel receives the increased water volume when expansion takes place as the system heats up and it maintains a positive pressure in the system. The expansion vessel contains a flexible diaphragm, which is initially charged on one side with nitrogen, but can be topped up with air when required. Select a suitable position for the expansion vessel. Mount it to the wall using the bracket provided (0-24L only, 35L and above are floor standing) and hard fix into pipework and insulate. Ensure that the top of the vessel is accessible for servicing. The pipe connecting the expansion vessel to the system should have a diameter of not less than 15mm and must not contain any restrictions.

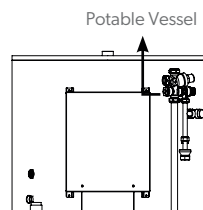

Hot Water Outlet

Run the first part of the hot water distribution pipework in 22mm. This can be reduced to 15mm and 10mm as appropriate for the type of tap etc. Your aim should be to reduce the volume of the hot draw-off pipework to a practical minimum so that the time taken for the hot water is as quick as possible. Do not use monobloc mixer tap or showers if the balanced cold connection is not provided. Outlets of this type can back pressurise the unit and result in discharge.

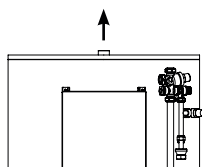

Potable Pipework

Secondary Circulation

On larger installations long pipe runs to draw-off points can cause significant volumes of water to be drawn off before an acceptable temperature can be reached. Secondary pumped circulation using a stainless steel or a bronze pump and combined with effective time and temperature controls can overcome this problem. Where secondary return circulation is required the pipework should be run in 15mm pipe and the pipework must be insulated to prevent excessive heat loss, leading to high running costs. A check valve must also be installed to prevent back flow. The secondary circulation tank connection can be seen diagram below.

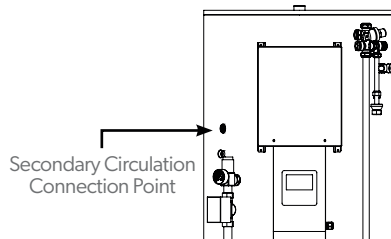

Commissioning

Potable System

First the precharge pressure in the expansion vessel must be checked to verify it is 0.3 bar below the inlet group setting ex. 3 bar inlet = 2.7 vessel. The valve is of the Schrader car tyre type. The adjusting of the pressure should be done before the expansion vessel is installed.

Check all the connections for water tightness including any factory-made connections such as the immersion heater and the temperature and pressure relief valve.

Prior to filling, open the hot tap furthest away from the cylinder to expel air. Open the cold main isolation valve and allow the unit to fill. Once the cylinder has been fully commissioned it should be heated to its normal operating temperature.

Heating System

The fill flush and flow meter is an important component of any heat pump system. It is provided in all Joule Heat Pump kits. For all heat pump systems a flow rate of over 7 l/min is required. It provides connections for the fill and flush ports of the heating system flush pump for installation and ongoing servicing.

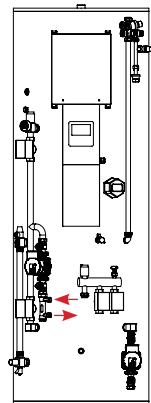

Kodiak Compact

Product Schematics

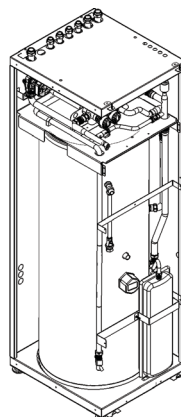
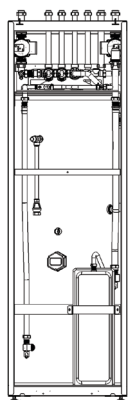

Left Side View

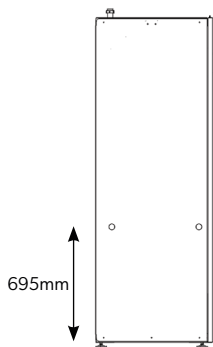

Front View

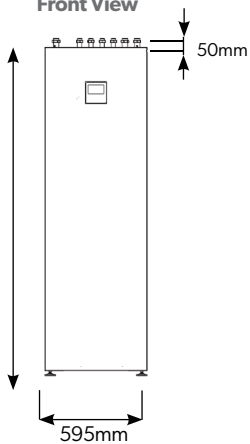

Right Side View

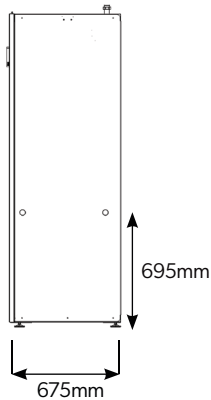

Top View

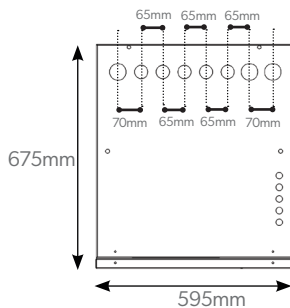

Transporting the unit

Transport and Handling

The Kodiak Compact unit is delivered fully packaged and fixed to a wooden pallet base. Care should be taken when transporting the unit ensuring that the casing is not damaged by impact.

At least two people should lift the unit to prevent injuries. The unit must be stored in a dry area and must never be dropped during handling. Packaging should only be removed at the installation location. This will help protect the casing and components. The unit must be installed on a level floor with the required load bearing capability.

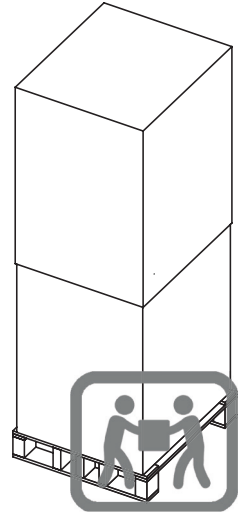

The cylinder unit must be transported in an upright position only.

Suitable Location

Care should be taken that the recommended minimum distance around the unit for service and maintenance works to be carried out. Enough access to allow maintenance of the valves should be considered. In addition, the immersion heater is 400mm in length and this distance should be considered to allow withdrawal for servicing if required.

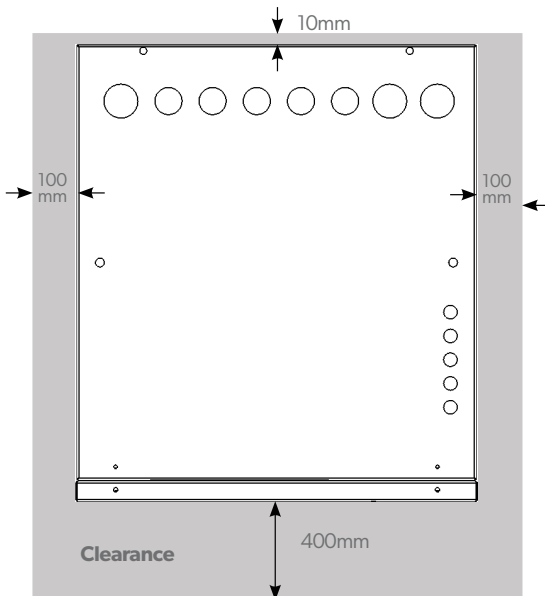

When using the adjustable feet, ensure that the floor is strong enough. Install the unit where it is not exposed to water/excessive moisture. Particular attention is needed if sitting in a garage or outbuilding as the unit should be protected from frost. All exposed pipework must be insulated. The unit must be installed upright on a base capable of supporting its weight when full (please see the technical specification section for weights).

Installing the unit

Installation space

- Ensure to leave the appropriate space as indicated in the drawing.
- Installation site should be secured with adequate ventilation so that the components of indoor unit will not be damaged from overheating.

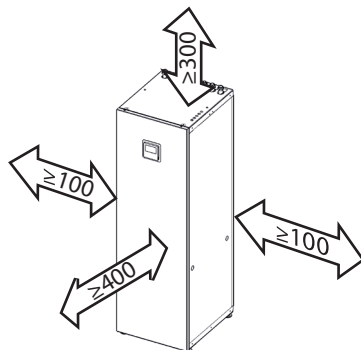

Moving the unit with a fork lift.

- Insert the fork into the wooden pallet at the bottom of the unit carefully. Be careful that the fork does not damage the unit.
- When moving the unit, take care not to cause damage through impact with the environment. Do not remove packaging until the unit has reached its final installation destination.

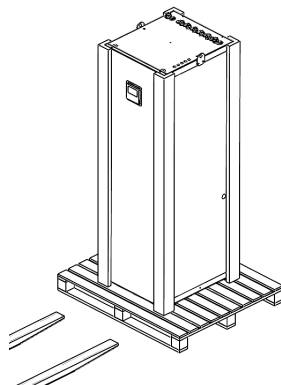

Moving the Unit Indoors

- Select the moving route in advance.
- Be sure that moving route is safe from weight of the unit.
- Transport the Unit carefully with a Hand truck.

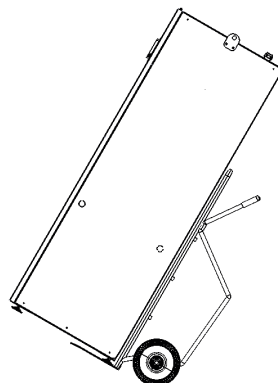

Electrical

System Overview

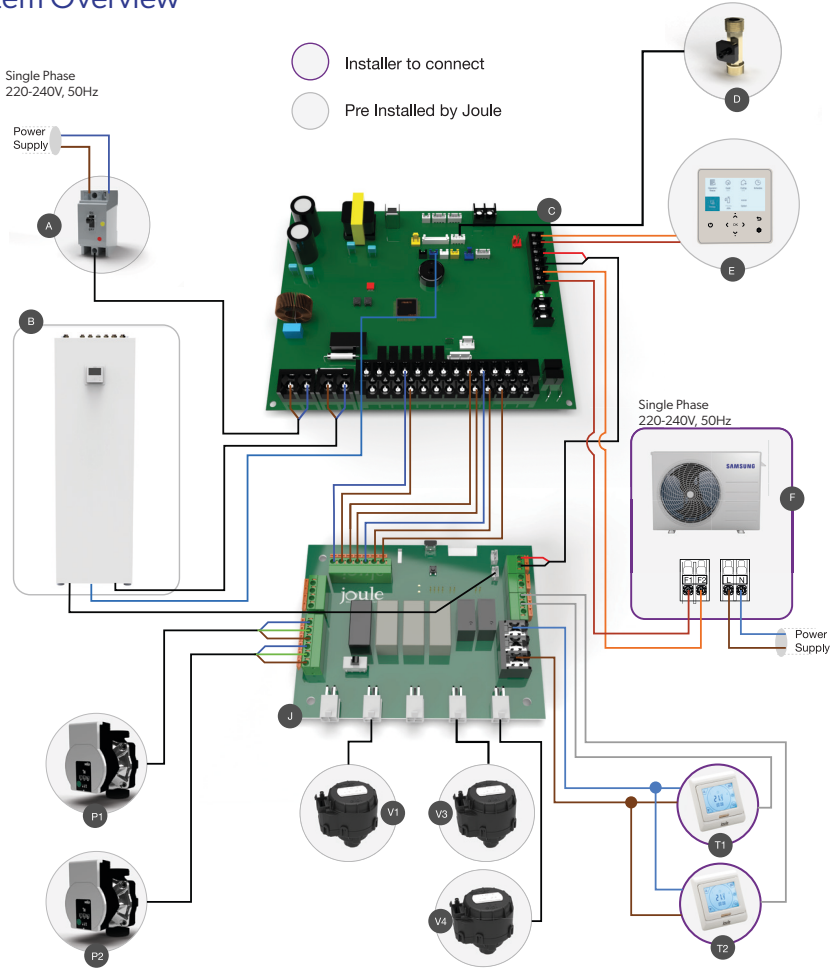

	Description	Item Codes		Description	Item Codes
A	Samsung 30A ELCB	HZC-0000A25-70	P1	Wilo Primary Circulating Pump	HZC-0000A25-60
B	Kodiak Compact	HUKC-G6210C-3C	P2	Wilo Secondary Circulating Pump	HZC-0000A25-60
C	Samsung MIM-E03CN/DN	HZSMC-G600000J	T	Joule E91 room thermostat	UZS-E91-TS0230
D	Samsung Flow Sensor	HZSMC-G600000J	V1	DHW - Motorized Zone valve	TZM-I-PP0022MM
E	Samsung Touchscreen Controller	HZSMC-G600000J	V3	Heating Valve 2 - Motorized Zone valve	TZM-I-PP0022MM
F	Samsung Outdoor Unit	HHSM-G6000xx-1	V4	Heating Valve 1 - Motorized Zone valve	TZM-I-PP0022MM
J	Joule Kodiak PCB	TZ-W-0000000W			

Electrical

Kodiak Compact Power Supply

The table below outlines the power requirements for the Kodiak Compact (MIM-E03(CN/DN))

Indoor Unit	Load	Power Supply	Power Cable	MAX. Length	Type GL
			mm2 wires	m	A
MIM-E03(CN/DN)	1)Booster Heater (3kw)	1Ø, 220-	4.0 / 3	<10m	20
			6.0 / 3	10m<L20m	20
	Booster Heater (~3kw) + Backup Heater (~3kw)	240Vac, 50Hz	6.0 / 3	<10m	40
			8.0 / 3	10m<L20m	40

1) This is the standard setup in a Kodiak Compact.

Power Supply Cable Entry

All electrical wiring must be carried out by a competent installer and be installed in accordance with current local Wiring Regulations.

The cable entry points are located on top of the unit. The cable can enter through the rubber grommets provided or the grommet can be replaced with a suitable cable gland. Ensure all cables are secured using the fixings provided.

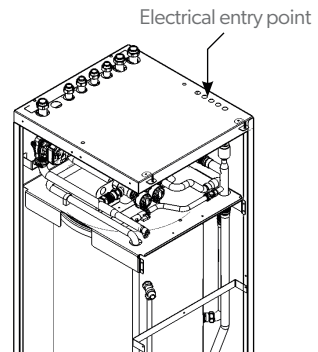

Power Supply Connections

Connect 'Live' and 'Neutral' power line with the terminals marked 'L, N' of the ELCB which is located inside the units electrical enclosure.

Connect the 'Protective Earth' line with the 'Earth screw' inside the units electrical enclosure. The rear casing of the units electrical enclosure is the termination point for all Protective Earth Connections. Please use earth termination points provided.

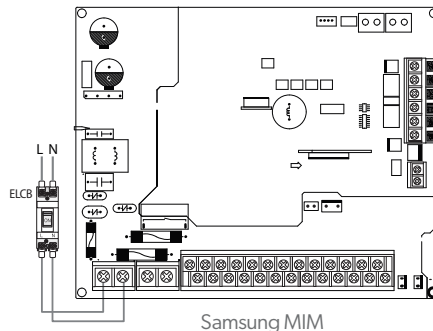

Electrical

Protective Earth

All pre-installed components are earthed. The integrity of a protective earth system relies on its primary connection. It is the installers responsibility to ensure the rear of the units electrical enclosure casing is earthed, therefore providing a protective earth connection to all system components.

Connecting the communication cable

The communication cable is the signal between the outdoor unit and the MIM casing.

Using a two-core cable connect the terminals F1 & F2 of the outdoor unit to the terminals F1 & F2 of the MIM casing.

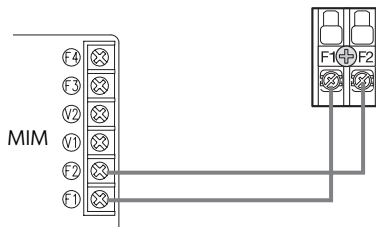

Connecting External Controls

Connection of external controls to the Kodiak Compact unit are made directly to the 'Joule Kodiak PCB' which is located inside the metal electrical enclosure, as detailed in the image shown on the right.

There is a dedicated 230V AC supply to power the external controls. These terminals are labelled 'External Controls Power', specifically

'L, N & E' on the Joule PCB.

The switched live input from the external controls should be connected to the terminals labelled 'Zone 1' S/L, 'Zone 2' S/L and 'Zone 3' S/L on the Joule PCB, as detailed in the image below.

N.B. Applying a 230V switched live to the terminal 'Zone 1' S/L will activate 'Heating Zone Valve 1'.

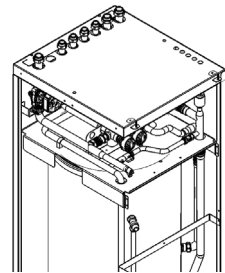

WARNING!

All external controls are 230V AC Connections

Example External Controls

A sample schematic showing examples of different types of external controls and how they connect to the 'Joule Kodiak PCB' is displayed on page 41 & 42.

Temperature & Pressure Relief Valve

Temperature & Pressure Relief Valve Pipework

Before placing the Kodiak Compact unit into position take note of the temperature and pressure relief discharge pipe route options. There are left and right points on the Kodiak Compact unit to exit the relief pipework. To access and connect the pipe work follow guidelines listed below.

1. Remove the two wing nuts at the top of the front panel.

2. Slide front panel upwards slightly and open carefully.

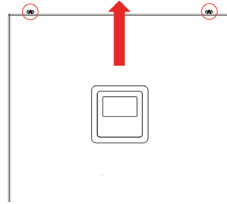

3. Disconnect the quick release coupler connecting the main remote controller cable and the control board cable



Connect the tundish and route the discharge pipe which must be routed in accordance with Building Regulations - Part G3 of schedule 1.

When operating normally water will not be discharged from the temperature and pressure relief valve. Water discharge from the temperature and pressure valve will only occur under fault conditions. The tundish is pre-fitted as shown below.

The discharge pipe (D2) coming from the tundish should terminate in a safe place where there is no risk to persons near the discharge, be made of metal:

- Be at least one pipe size larger than the nominal outlet size of the safety device unless its total equivalent hydraulic resistance exceeds that of a straight pipe 9m long, i.e. discharge pipes between 9m and 18m equivalent resistance length should be at least two sizes larger than the nominal outlet size of the safety device, between 18 and 27m at least 3 sizes larger, and so on.
- Bends must be taken into account in calculating the flow resistance. Refer to Table 1 and the worked example. An alternative approach for sizing discharge pipes would be to follow BS6700 Specification for design, installation, testing and maintenance of services supplying water for domestic use within buildings and their curtilages.
- Be installed with a continuous fall. The discharge must be visible at the final point of discharge.

TABLE 1

	G1/2			G3/4			G1		
Min. size of discharge pipe D1	15mm			22mm			28mm		
Min. size of discharge pipework D2 from tundish	22mm	28mm	35mm	28mm	35mm	42mm	35mm	42mm	54mm
Max. length of straight pipe (no bends or elbows)	Up to 9mm	Up to 18mm	Up to 27mm	Up to 9mm	Up to 18mm	Up to 27mm	Up to 9mm	Up to 18mm	Up to 27mm
Deducts the below from the maximum length for each bend or elbow in the discharge pipe	0.8m	1m	1.4m	1.0m	1.4m	1.7m	1.4m	1.7m	2.3m

Sizing of copper discharge pipe (D2) for a temp, relief valve with a G1/2 outlet size (as supplied)

Temperature & Pressure Relief Valve

Examples of Discharge Arrangements

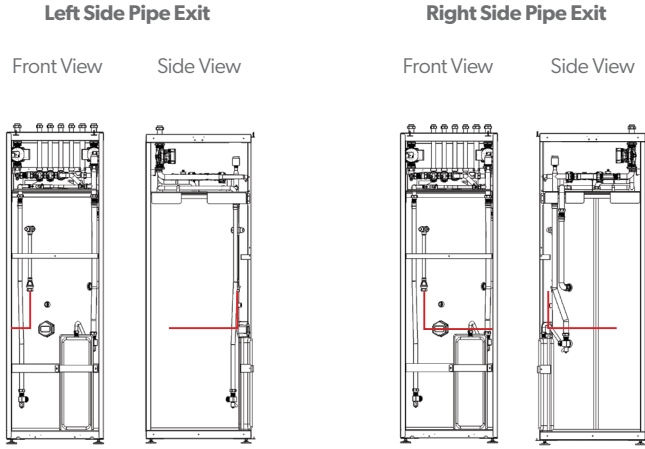

Waterway Schematic

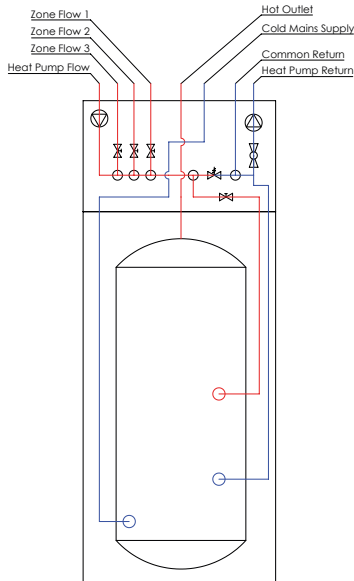

Heating System Connection

Heat Pump Primary Connections

Connect the primary connections as shown below. The direction of flow is indicated by the arrows in the diagram below. In the Kodiak Compact the primary circulating pumps are pre-fitted along with the hot water motorised valves.

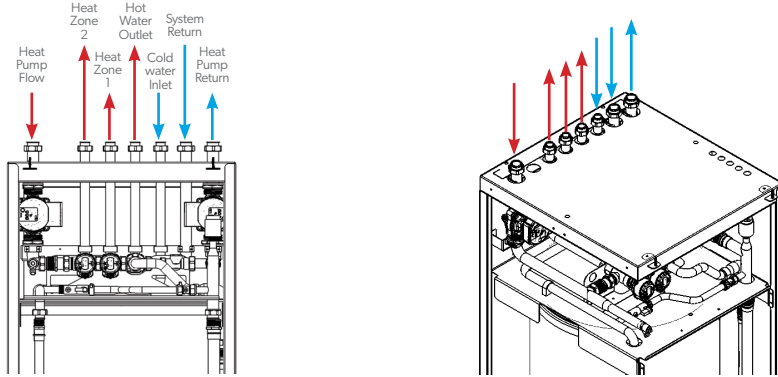

Heating System Pipe Connections

Connect the heating zone connections as shown below. In the Kodiak Compact the heating zone motorised valves are pre-installed along with the heating system expansion vessel. The circulating pump for the Heat pump system is also pre-fitted within the casing.

All heating zone returns should be joined and return via system return as shown below.

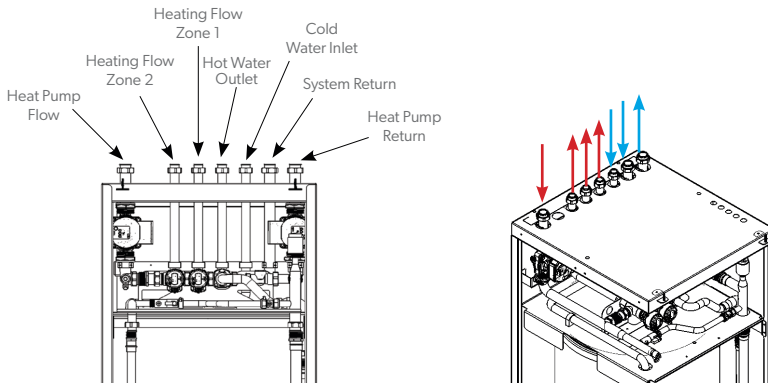

Potable Pipework

Fitting the Inlet Control Group

Excess pressure can lead to the cylinder bursting. The inlet control set supplied has an expansion relief valve with a 15mm connection to allow it to be connected to a tundish, this is pre-plumbed. Make sure that there is enough space for future maintenance and for connection of the discharge pipe for the expansion relief valve. It is essential that this connection is not covered or closed.

The cold inlet must be piped into the top of the inlet control group. It is recommended to install a full bore isolation valve on the cold inlet for maintenance and servicing of the valve.

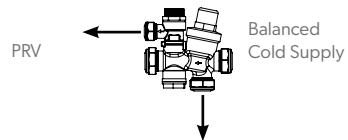
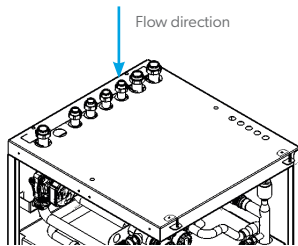

The water supply should be checked to ensure it can meet these requirements. If necessary, consult the local water authority regarding the likely pressure and flow rate availability. Consideration should be given to upgrading existing 1/2" (15mm) cold mains pipework to a larger size if the recommended minimum pressure / flow rate is not being achieved. Joule™ recommend that primary pipework used has a minimum diameter of 22mm to ensure low pressure loss.

Potable Expansion Vessel

The expansion vessel receives the increased water volume when expansion takes place as the system heats up and it maintains a positive pressure in the system. The expansion vessel contains a flexible diaphragm, which is initially charged on one side with nitrogen, but can be topped up with air when required. Select a suitable position for the expansion vessel. Mount it to the wall using the bracket provided (0-24L only, 35L and above are floor standing) and hard fix into pipework and insulate. Ensure that the top of the vessel is accessible for servicing. The pipe connecting the expansion vessel to the system should have a diameter of not less than 15mm and must not contain any restrictions.



Hot Water Outlet

Run the first part of the hot water distribution pipework in 22mm. This can be reduced to 15mm and 10mm as appropriate for the type of tap etc. Your aim should be to reduce the volume of the hot draw-off pipework to a practical minimum so that the time taken for the hot water is as quick as possible. Do not use monobloc mixer tap or showers if the balanced cold connection is not provided. Outlets of this type can back pressurise the unit and result in discharge.

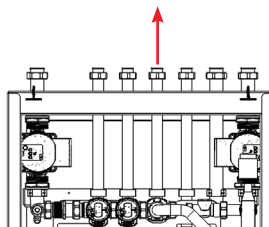
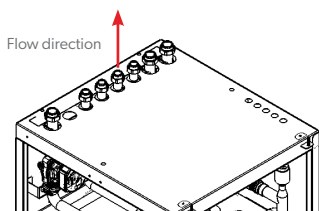

Commissioning

Potable System

Refer to page 41.

Heating System

The fill flush and flow meter is an important component of any heat pump system. It is provided in all Joule Heat Pump kits. For all heat pump systems a flow rate of over 7 l/min is required. It provides connections for the fill and flush ports of the heating system flush pump for installation and ongoing servicing. See page 26.

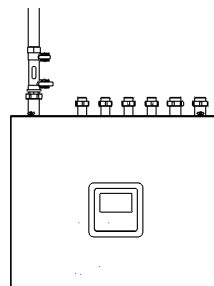

Maintenance

General

Servicing should only be carried out by competent installers and any spare parts must be purchased from Joule



Never bypass any safety devices or operate the unit without being fully operational.

Draining

Switch the electrical power off (important to avoid damage to element). Isolate the power supply to the unit. Turn off the cold water supply valve. Open hot water tap. Open the drain valve. The unit will drain.



Water drained off may be very hot!

Annual Maintenance

The Cylinder/ Indoor unit require annual servicing in order to ensure safe working and optimum performance. It is essential that the following checks are performed by a competent installer on an annual basis. This is commonly done at the same time as the annual heat pump service.

- Twist the cap for the expansion relief valve on the inlet control set and allow water to flow for 5 seconds. Release and make sure it resets correctly.
- Repeat with the pressure/temperature relief valve. In both cases check that the discharge pipework is carrying the water away adequately. If not, check for blockages etc. and clear.
- Check that any immersion heaters fitted are working correctly and that they are controlling the water at a temperature between 55°C and 65°C.
- Check the pressure in the expansion vessel is charged correctly. Turn off the water supply to the unit and open a hot tap first. The air valve on expansion vessel is a Schrader (car tyre) type.
- Air or CO₂ may be used to charge the expansion vessel. Unscrew the head on the inlet control set and clean the mesh filter within.

The Service Log Book supplied with this unit should be updated at each service.



Your guarantee may be void if you cannot produce proof of annual servicing.

Samsung Controller

Overview of the Samsung Controller Initial Start Up

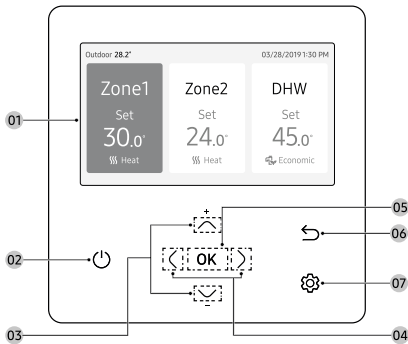



Location	Function
1	Operation status display - Displays the operation/function settings and statuses.
2	Operation On/Off button (LED display) - Turns the Air to Water Heat Pump power On / Off
3	Up/Down button - Moves between items vertically or changes the set temperature.
4	Left/Right button - Moves between items horizontally or changes the item value.
5	OK button - Saves your new settings.
6	Save & Return button - Saves your new settings and returns to the previous step.
7	Option button - Selects the detailed setting function.

Initial Start Up

Please refer to controller symbols and button functions on pages shown on the left for further guidance on the heat pump controls.

1. Ensure that both the outdoor and indoor units are correctly wired and plumbed prior to turning on.
2. Flush the system at 110% of system flow rate in both directions.
3. Once the system has been power flushed you must now fill the system with Glycol.
4. The Glycol should be pre mixed before putting it into the system and a solar filling station is ideal for filling the system, use the connections on the fill/flush and flow meter to add the glycol.
5. Do not put Neat Glycol into the system, failure to do this may cause the glycol to block the heat exchanger or block the pipes within the heat emitter circuit.
6. Run the solar filling station for at least an hour to purge all the air from the system.
7. Turn on power to the indoor unit first. Then turn on power to the outdoor unit second.
8. The outdoor unit will start flashing. It flashes 'scanning' while connecting the indoor and outdoor units.
9. Once scanning disappears from the screen the system is ready for testing.

Setting up the controller and the time

1. Push the Gear Icon 
2. Use the Arrows to highlight option and push the right arrow
3. Use the down arrow until User mode is highlighted, then push the right arrow
4. Use the down arrow until Wired Remote is highlighted and push the right arrow
5. Use the Down arrow to Current time and push the right arrow
6. Date will be highlighted, push the right arrow and date format should be displayed.
7. Push OK, now you can set the date by using the arrows.
8. Once set push OK, and you should then return to the current time menu with date highlighted.
9. Use down arrow to highlight time and right arrow to enter time menu
10. Set clock to 24 hr format by using down arrow, then left and right arrows to high light hours and minutes.
11. Use up and down arrows to set the time.
12. Once complete push OK button.
13. Use the back button  to return to the home screen.

How to Add or delete Schedules

1. Push the Gear Icon to enter the menu 
2. Use the right arrow to high light schedule, then push ok
3. To add a schedule push ok, when add a schedule is highlighted

4. Select daily schedule using up and down arrows, push right arrow to enter
5. Select type of schedule using up and down arrows, change from quiet to DHW
6. Push right arrow to select either Off, or what power mode you wish for the DHW mode to start in.
7. We strongly recommend that standard is selected.
8. Use right hand arrow to highlight the hour and minutes, use up and down arrows to adjust.
9. Push OK to save.
10. To edit a schedule, use up and down arrows to highlight schedule, use left and right-hand arrow to select edit, push ok and repeat above steps to edit.
11. To delete schedule, highlight delete, push ok and schedule is deleted.
12. Push  to return to home screen.

How to enter Service Mode

1. Using two hands, push and hold the up and down arrows for 10 seconds
2. Password will appear, the password is 0202
3. Use arrows to enter password
4. Push OK
5. You are now in the service Menu

Self-Test Mode

- To access the Self-test mode, you must enter the Service Menu.

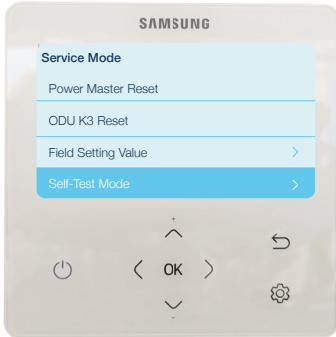

- Once in the service menu Use the Down arrow to scroll down to self-test

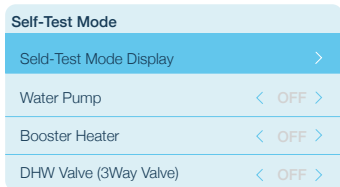

- Use the right arrow to enter the menu
- Use and down arrows to highlight component to test
- Once highlight use the right arrow to enable component

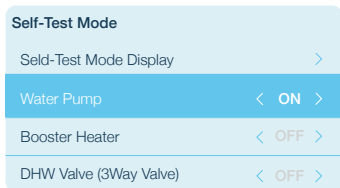

- You can go up to self-test display at any point, use the right arrow to enter

Self-Test Mode Display



Water Inlet Temp: 23°C
 Water Outlet Temp: 22°C
 Backup Heater Outlet Temp: -
 Mixing Valve Outlet Temp: -
 Tank Temp: 50°C
 Indoor Ambient Temp: 20°C
 Indoor Ambient Temp. (Zone 2): -
 Water Outlet Temp. (Zone 1): -
 Water Outlet Temp. (Zone 2): -
 Thermostat #1 (Zone 1): Heat

Field setting values

- Enter Service mode
- Use down arrow to highlight field setting value
- Push right arrow to enter
- Use up and down arrows to select sub menu required.
- Example for weather comp and heating flow highlight 20 – water law
- Push right arrow to enter sub menu
- You will see the individual settings within this menu.
- Use up and down to set FSV
- Example 2011 Low set is 15, High set is 2.0
- Once set push OK and Saving FSV will be displayed.
- You will then return to the heat sub menu.
- You can then use the up and down arrows to highlight other heat settings and right arrow to enter.
- To go back to FSV menu use and you can then move to other sub menus such as DHW.
- To exit FSV mode push until you return to the front Screen.

Energy Monitoring Function

- In order to enable the energy monitoring function, please set FSV 3083.
- Enter the service mode and go to FSV 3083 within the DHW settings.

3. Set 3083 to 3 kw.
4. Now use the  to return to the front screen.
5. Use the  to enter user menu, and use the arrows to highlight "Energy"
6. Push the ok button to enter this menu
7. Energy usage should be highlighted, push right arrow to enter
8. From here you have four options.
9. Instantaneous usage
10. Weekly energy usage
11. Monthly energy usage
12. Yearly energy usage
13. Use the arrows to navigate the menus.
14. Example: weekly usage> weekly consumption> display will then show current week, use left hand arrow to look at previous week.
15. Push  to return to previous sub menu or push several times to exit to home screen.

Turning on Heating and DHW

1. Use the  arrow to ensure you are on the front screen
2. Use the right and left arrows to highlight the function to turn on.
3. To turn on DHW, use the right arrow so DHW function is highlighted
4. Once highlighted push the power button and DHW should display.
5. To set temperature Push ok button whilst DHW is highlighted
6. Use up and down arrows to set water temperature
7. Push OK button to set power mode, this

should be set for Standard.

8. Use up and down to select Standard and push OK.
9. Once complete push  to return to front Screen

To set heating to ON

1. Use left and right arrows to highlight Zone
2. Push power button to enable heating
3. Screen display will show 0.0
4. Push the OK button to enter heating info
5. From here you can see flow temps
6. Use the  to exit this screen.
7. 0.0 must be on for the heat pump to detect run signals from the heating system.

How to setup service call number

1.

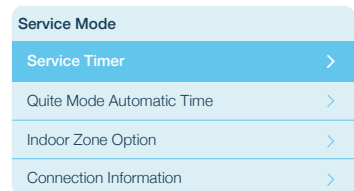

2.

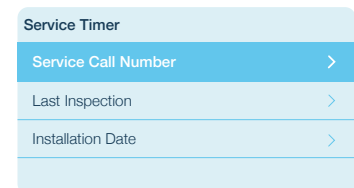

3.

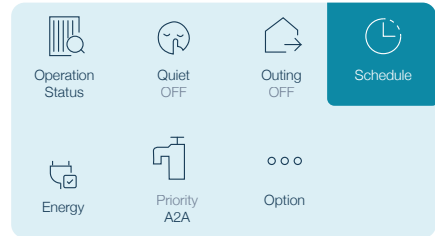
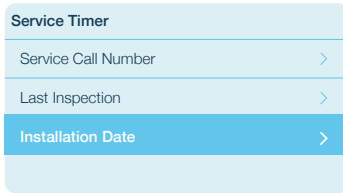

Setting Quite Mode Manually

1. Push the Gear Icon to enter the menu
2. Quite mode can then be turned on or off manually by selecting the 'Quiet' icon
3. if quiet mode is turned on manually, the output of the heat pump will be reduced. Quiet mode must be switched to off to return the heat pump output to its normal capacity.

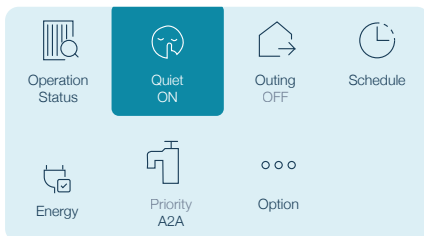

Setting Quite Mode Automatically

1. Push the Gear Icon to enter the menu
2. Enter the schedule menu

3. Select add a schedule

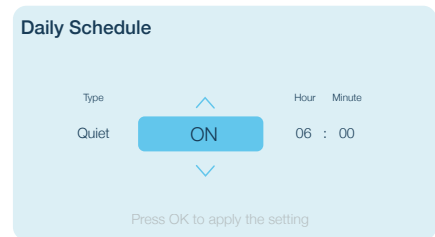
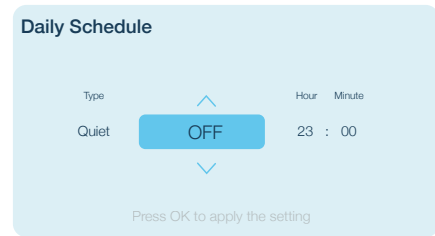

4. Choose to set the schedule daily weekly or yearly
5. Set the 'ON' and 'OFF' times for the schedule
6. Quiet mode when automatically come on during the chosen time period

How to read water flow rate

1. Enter Service mode
2. Use the arrows to move to 'Indoor Zone Option'

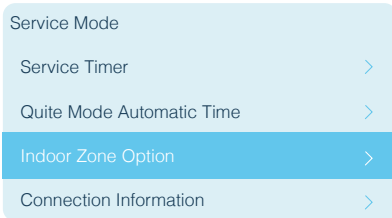

3. Press the right arrow button
4. Use the down arrow to find 'Indoor Zone Status Information'

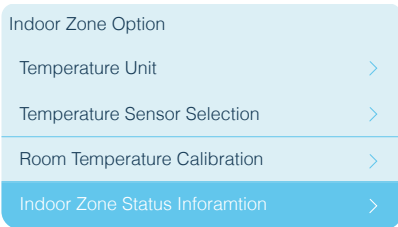

5. Press the right arrow button
6. Use the down arrow to navigate to the 'Flow Sensor' information

Smart Plumb Pre-plumbed

Mechanical Diagram

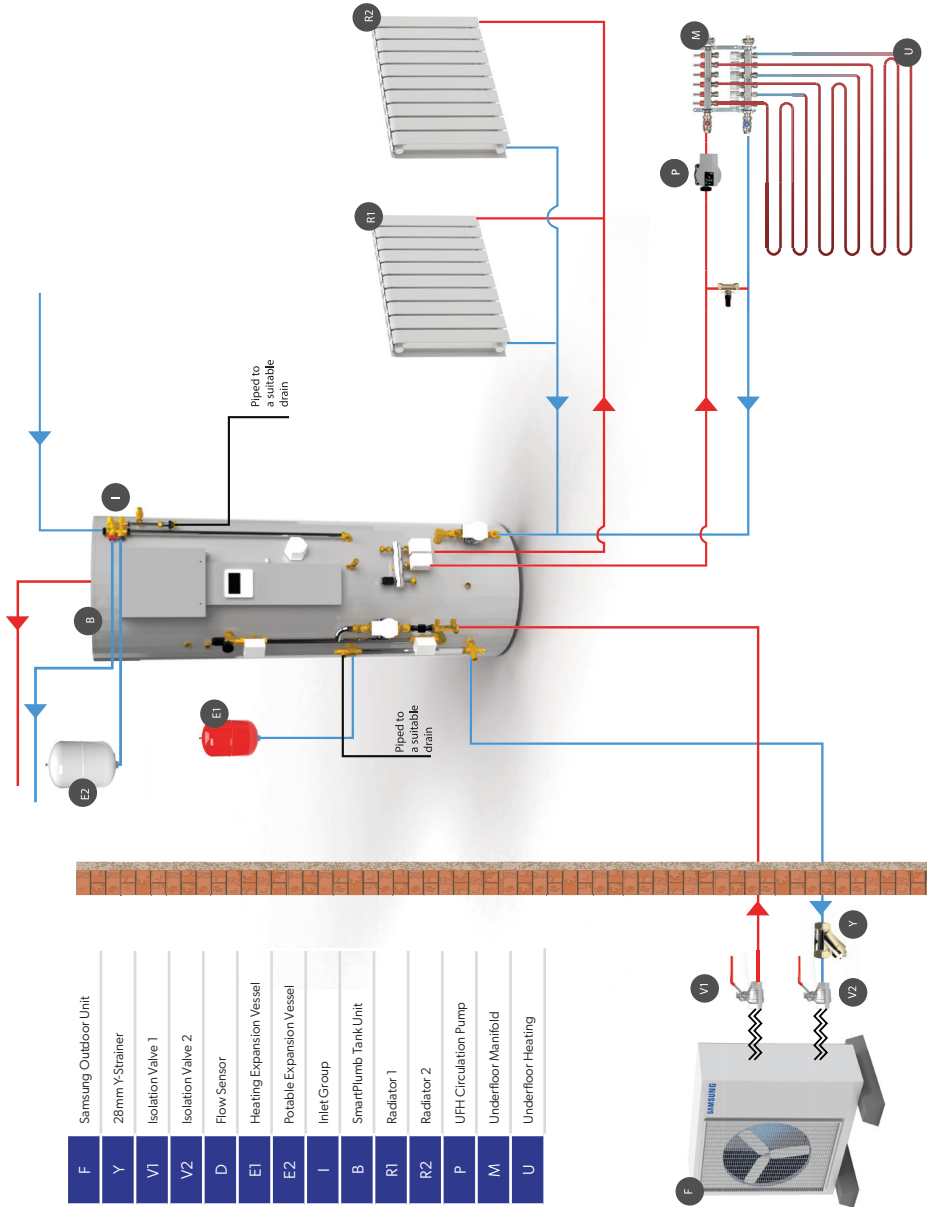

F	Samsung Outdoor Unit
Y	28mm Y-Strainer
V1	Isolation Valve 1
V2	Isolation Valve 2
D	Flow Sensor
E1	Heating Expansion Vessel
E2	Potable Expansion Vessel
I	Inlet Group
B	SmartPlumb Tank Unit
R1	Radiator 1
R2	Radiator 2
P	UFH Circulation Pump
M	Underfloor Manifold
U	Underfloor Heating

Smart Plumb Pre-plumbed

Electrical Diagram

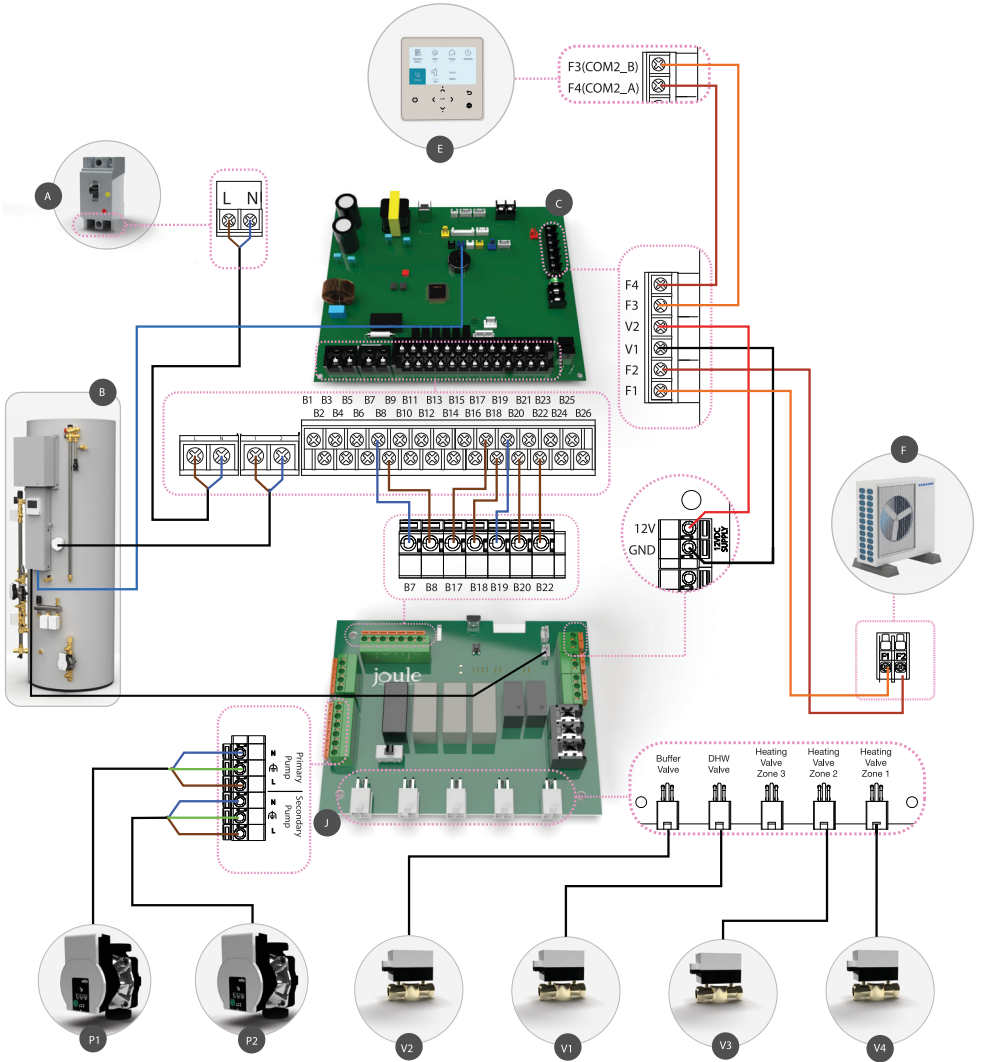

Kodiak Compact Installation

Mechanical Diagram

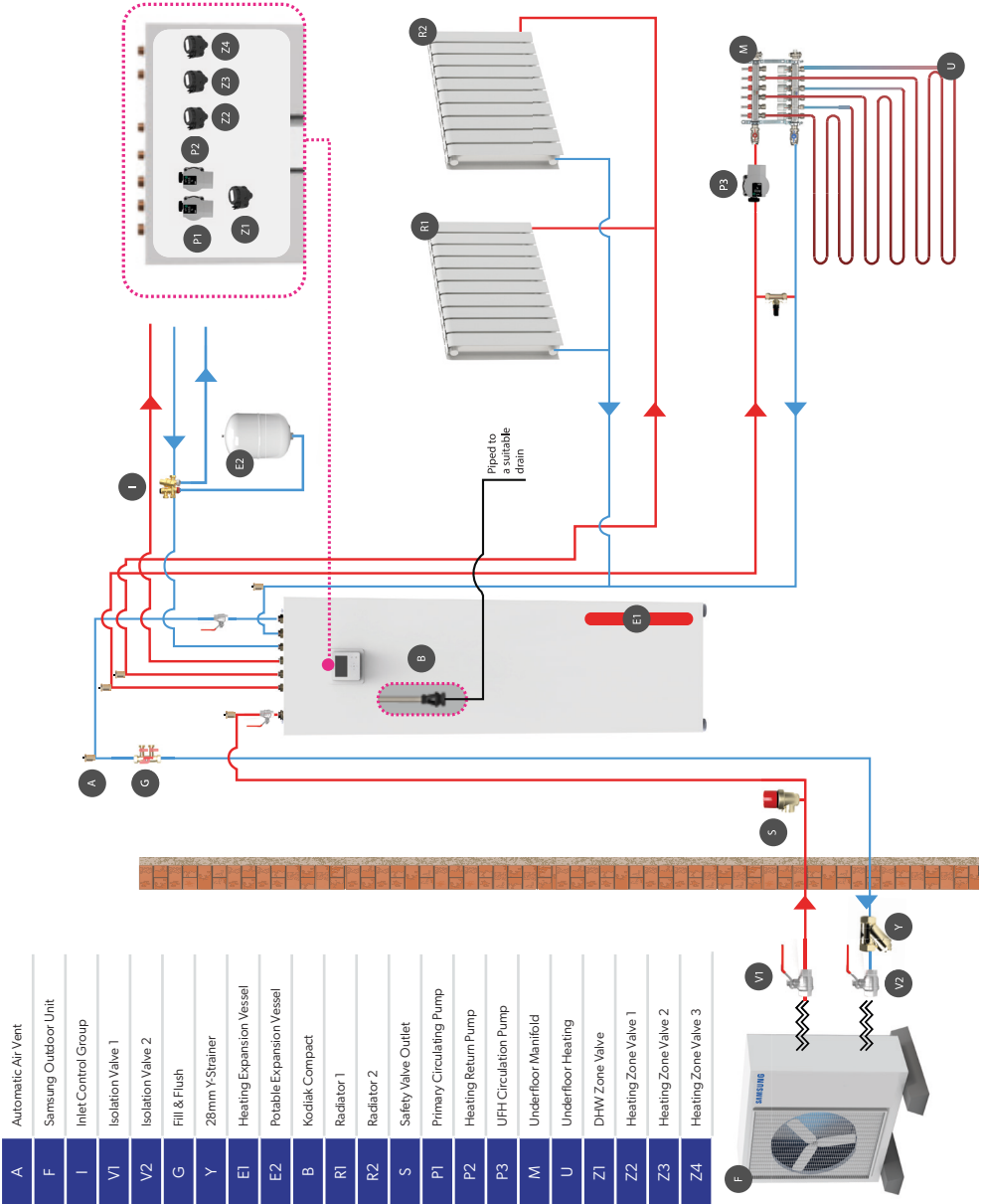

Kodiak Compact Installation

Electrical Diagram

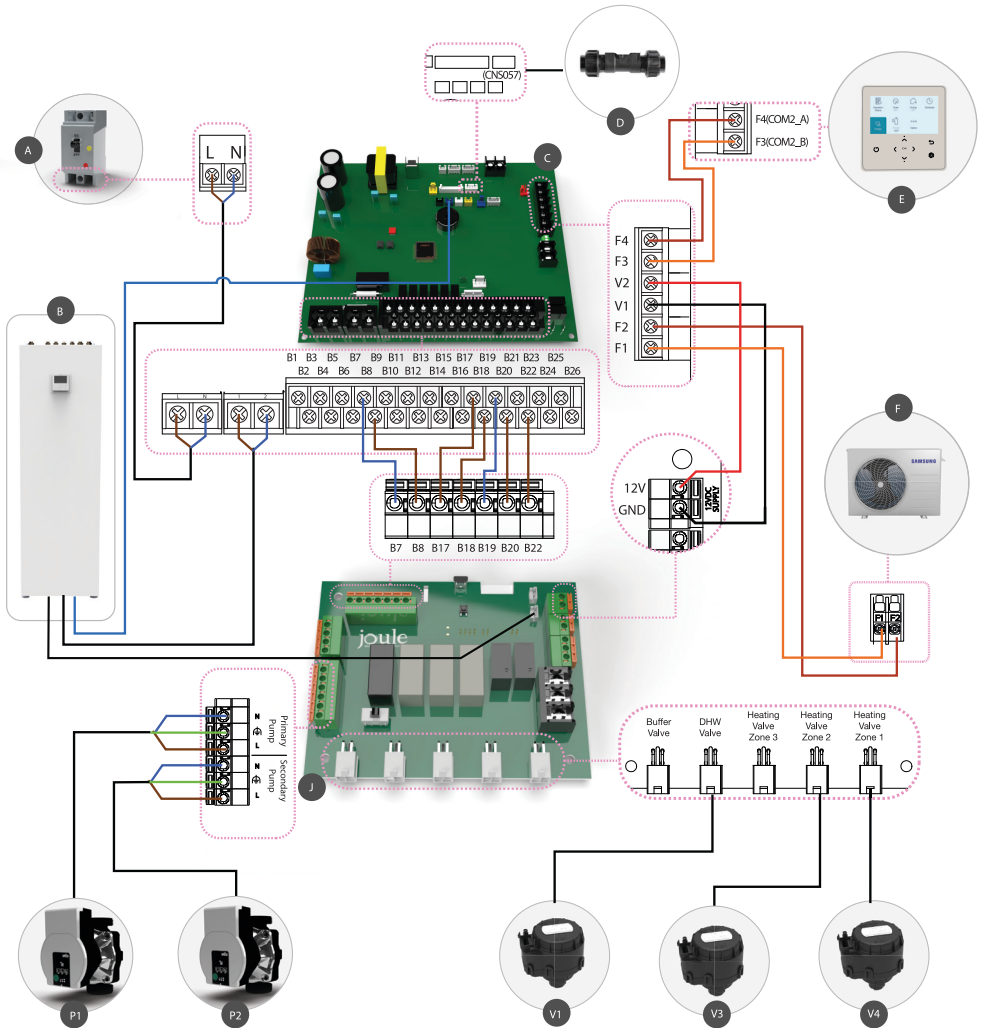

Unplumbed Installation

Mechanical Diagram

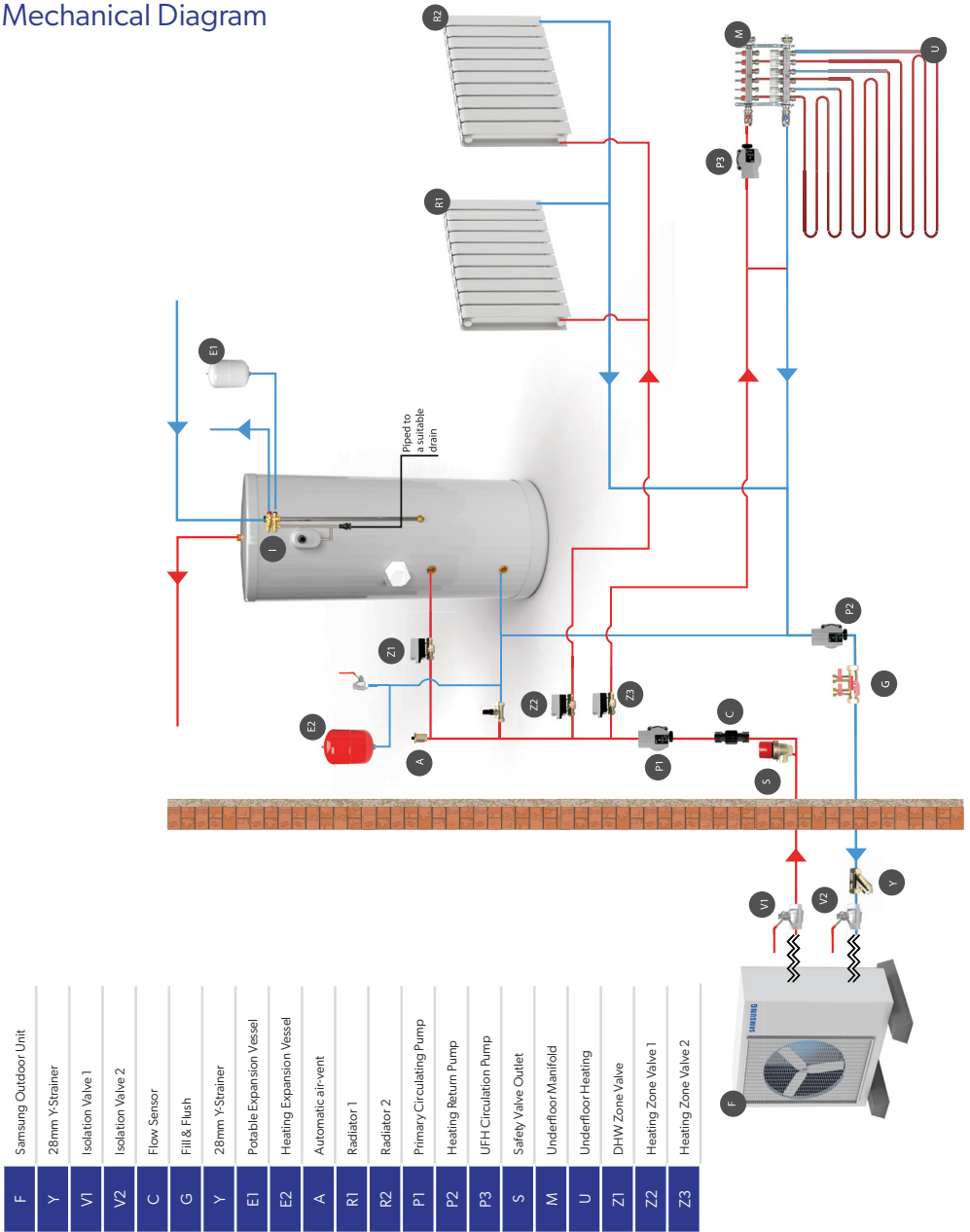

Unplumbed Installation

Electrical Diagram

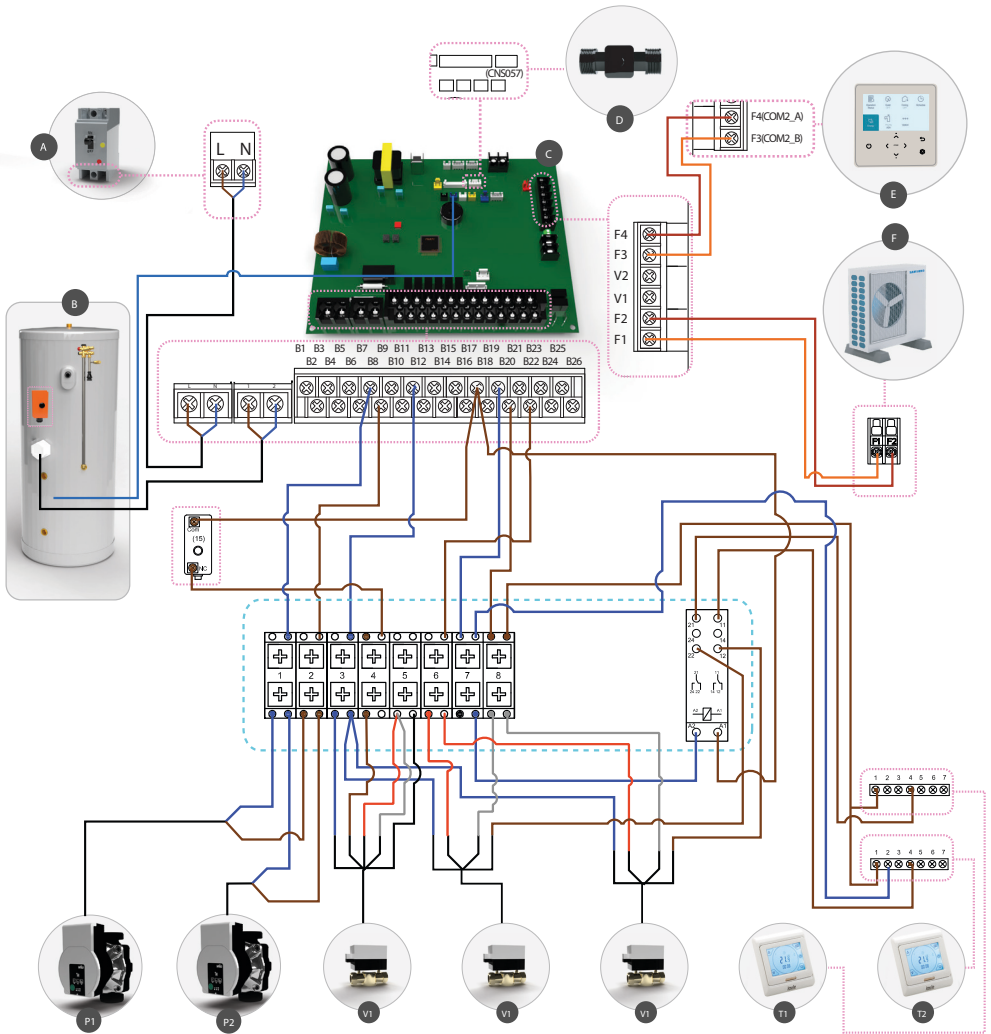

Field Setting Parameters

Field Setting Parameters For Smart Plumb Cylinder and Kodiak Compact Units - 2 & 3 Zone



If you set a field setting and go back to check it, it will not have changed. The field setting does not get written to the PCB unless you push Ok after changing it.

Samsung Gen 6 Monobloc #FSV REVIEW - 26th May 2021

Applicable Products: SmartPlumb, Kodiak Compact, Standard & Slimline PrePlumb.

Menu Code	Menu Des.	Sub Menu	Code	Screen Position	Function			Pre-commissioning Setting	#FSV Range		
					Item	Step	Unit		De-fault	Min	Max
10**	DHW	105*	1051	Left	Max DHW tank temperature	1	°C	50	55	50	70
20**	Heating	201*	2011	Right	Outdoor Temp. for Water Law - High (Max.)	1	°C	2	-10	-20	5
			2012	Left	Outdoor Temp. for Water Law - Low (Min.)	1	°C	15	15	10	20
		202*	2021	Right	Outdoor Temp. for WL1 Heat - High (Max.)	1	°C	45	40	17	65
			2022	Left	Outdoor Temp. for WL1 Heat - Low (Min.)	1	°C	35	25	17	65
		209*	2091	-	External Thermostat Application #1	-	-	Use(Signal Only ON/OFF)	Not Use	Not Use	4

30**	DHW	301*	3011	-	Domestic Hot water Tank	-	-	Use(Hysteresis: Thermo Off)	Not Use	Not Use	2
	Heat Pump	302*	3021	-	Max Temp.	1	°C	50	55	45	55
			3025	-	Max. DHW Operation Time	5	min	As per Table 1	30	5	95
	Booster Heater	303*	3032	-	Delay Time	5	min	As per Table 1	20	20	95
	Disinfection	304*	3042	-	Interval	1	day	TUESDAY	Fri	Mon	Sun
			3043	-	Start Time	1	o'clock	3HOUR	23	0	24
			3044	-	Target Temp.	5	°C	55	70	40	70
			3045	-	Duration	5	min	15	10	5	60
	Forced DHW Operation	305*	3051	Left	Timer OFF Function	-	-	Use	Not Use	Not Use	Use

#FSV	Tank Volume	Setting
←180		50
	200	60
3025 & 3032	230	70
	250	75
	300	90
→400		95

Fault Codes

Error Code	Contents	Measure	Product op. in error condition	Error Type
			Outdoor unit / Comp. / Ind. unit	
101	Indoor unit communication error	Check the communication cable of indoor unit. Check the DC output voltage at the communication terminal.	Operation off	Communication error
102	Indoor unit/outdoor unit communication time-out error: errors in more than 6 packets	Check the outdoor communication cable connection. Check DC output voltage and the communication terminal.	Operation off	Communication error
121	Indoor temperature sensor (open/short error)	Check indoor unit room temperature sensor. Check indoor unit PCB connector CN41 (White)	Operation off	Indoor sensor error
122	Indoor unit Eva in sensor (Open/Short)	Check indoor unit pipe sensor. Check indoor PCB connector CN41 (White)	Operation off	Indoor sensor error
128	Indoor unit Eva in sensor disconnection	Check the disconnection of indoor unit pipe sensor.	Operation off	Indoor sensor error
153	Indoor floating switch secondary detection	Check indoor unit float sensor. Check indoor PCB connector CN5 (black)	Operation off	Self diagnostic error
202	Indoor/outdoor communication error (1 min)	Check the communication connection between indoor and outdoor units. Check the power line and communication cable connection status.	Operation off	Communication error
203	Communication error between indoor/outdoor INVIMAIN <-> MICOM (1 min)	Check MAIN MICOM Check INVERTER MICOM	Operation off	Communication error
221	Outdoor temperature sensor error	Check sensor connection status Check sensor location Check sensor resistance	Operation off	Outdoor sensor error
237	COND temperature sensor error	Check sensor connection status Check sensor location Check sensor resistance	Operation off	Outdoor sensor error
251	[Inverter] Emission temperature sensor error	Check sensor connection status Check sensor location Check sensor resistance	Operation off	Outdoor sensor error

Fault Codes

Error Code	Contents	Measure	Product op. in error condition	Error Type
			Outdoor unit / Comp. / Ind. unit	
440	Heating operation blocked	Check the operation setting state Check temperature sensor	Operation off	Self diagnostic error
458	Outdoor fan 1 error	Check input power connection status Check the connection status between the motor and outdoor unit of PCB Check indoor/outdoor fuse	Operation off	Self diagnostic error
461	[Inverter] Compressor startup error	Check the compressor connection status Check the resistance between different phases of the compressor	Operation off	Outdoor unit protection control error
462	[Inverter] Total current error / PFC over current error	Check the input power Check the coolant charging status Check the normal operation of outdoor fan	Operation off	Outdoor unit protection control error
464	[Inverter] IPM over current error	Check coolant charging Check the compressor connection status and normal operation Check the obstacles around the indoor and outdoor units Check whether the outdoor unit service valve is open Check whether the indoor/outdoor installation pipe/wiring are correct	Operation off	Outdoor unit protection control error
465	Compressor V limit error	Check the compressor connection status Check the resistance between different phases of the compressor	Operation off	Outdoor unit protection control error
466	DC LINK over/low voltage	Check input power Check AC power connection	Restart in 3 minutes	Outdoor unit protection control error
467	[Inverter] Compressor rotation error	Check the compressor connection status Check the resistance between different phases of the compressor	Operation off	Outdoor unit protection control error
468	[Inverter] Current sensor error	Check EEPROM DATA Check the normal operation of PCB	Operation off	Outdoor unit protection control error
469	[Inverter] DC LINK voltage sensor error	Check the input power connection Check the status of RY21 and R200 in the INVERTER PCB	Operation off	Outdoor unit protection control error
471	[Inverter] OTP error	Check EEPROM DATA Check the normal operation of PCB	Operation off	Outdoor unit protection control error

Fault Codes

Error Code	Contents	Measure	Product op. in error condition	Error Type
			Outdoor unit / Comp. / Ind. unit	
475	Outdoor fan 2 error	Check the input power connection status Check the connection status of the motor and the outdoor unit PCB Check the indoor/outdoor unit fuse	Operation off	Self diagnostic error
554	Gas leak error	Check the coolant charging status Check the indoor EVA sensor Check if the outdoor unit service valve is open Check that the indoor/outdoor installation pipe/wiring are correct	Operation off	Self diagnostic error
556	Capacities not matched	Check the option code of the indoor unit	Operation off	Outdoor unit protection control error
601	Communication error between the indoor unit and wired remote controller	Check the connection wire between the indoor unit and the wired remote controller	Operation off	Wired remote controller error
602	Communication error between the Master and Slave wired remote controllers	Check the option switch for defining the master and slave (only one master and one slave can exist)	Normal operation	Wired remote controller error
606	COM1/COM2 cross installation error	Check that wired remote controller is connected to the COM2 terminal of the indoor unit	Normal operation	Wired remote controller error
607	Communication error between the Master and Slave wired remote controllers.	Check the option switch for defining the master and slave (only one master and one slave can exist)	Normal operation	Wired remote controller error

Troubleshooting

Error Code	Meaning	Troubleshooting
E177	Emergency stop	Indoor unit (\$POUSPM kit) orders emergency stop. Check the indoor unit (\$POUSPM kit)
E201	Control kit quantity is mismatched.	Control kit quantity must be matched with outdoor unit 1 by 1. Check the \$POUSPM kit quantity. It must be 1EA.
E403	Detection of outdoor freezing when compressor stops.	Outdoor unit (condenser) froze. Check condenser.
E404	Protection of outdoor overload when compressor stops.	Compressor is overloaded. Please check same as E461 and check compressor when it starts.
E416	Discharge temperature of a compressor in an outdoor unit is overheated.	Discharge temperature is overheated.
E440	Heating operation is not available since the outdoor air temperature is over 35 degrees.	Check the outdoor temperature.
E441	Cooling operation is not available since the outdoor air temperature is lower than -15 degrees.	Check the outdoor temperature.
E465	Compressor overload error	Compressor is overloaded. Please check same as E461 and check compressor when it starts.
E468	Current sensor error	Exchange INVERTER PBA.
E471	Outdoor EEPROM error	EEPROM date is wrong. Exchange EEPROM or MAIN PBA. (This error doesn't occur in EMF 150-AM)
E474	IPM (IGBT Module) or PFCM temperature sensor error	Exchange INVERTER PBA.
E484	PFC overload error	Check reactor located in control plate. If reactor is normal, exchange INVERTER PEA.
E500	IPM is over heated	Check INVERTER PBA's temperature. Power off and cool down INVERTER PBA, and then restart the outdoor unit.
E556	Capacity mismatching between indoor and outdoor	EEPROM data is wrong. Exchange EEPROM or MAIN PBA
E557	Option code miss matching among the indoors (only for DPM)	EEPROM data is wrong. (This error doesn't occur in EMF 150-AM)
E911	Emergency stop	Ensure flow sensor is fitted onto pipework and connected to Samsung PCB. Ensure flow rate is above 16 litres per minute. Ensure all air is removed from system. Check circulation pumps speed setting. Check zone valves are not sticking closed. Check direction of flow sensor on pipework. Check direction of pump on pipework. Check direction of Flow Meter on pipework.
E912	Emergency stop	Check circulation pumps are not operating. check flow sensor is installed on horizontal pipework. Ensure 150mm of horizontal pipework each side of flow sensor.

Control Kit EHS Mono-block Wiring

Terminal No.	Function	Description
N	230V AC Neutral Output	Neutral Output to DHW Immersion
L	230V AC Live Output	Live Output to DHW Immersion
B1	230V AC Neutral Output	Neutral Output to Backup Immersion Cable
B2	230V AC Live Output	Live Output to Backup immersion Cable
B4	230V AC Live Output	Live Output to Backup Boiler (1.5mm ² cable)
B5	230V AC Neutral Output	Neutral Output to Circulation Pump (1.5mm ² cable)
B7	230V AC Neutral Output	Neutral Output to DHW Zone Valve (1.5mm ² cable)
B8	230V AC Live Output	Live Output to Circulation Pump (1.5mm ² cable)
B10	230V AC Live Output	Live Output to Heating Zone Valve 1 (Brown Cable) - Where no Buffer installed
B14	230V AC Live Output	Live Output to Heating Zone Valve 2 (Brown Cable) - Where no Buffer installed
B15	230V AC Neutral Output	Neutral output to Heating Zone Valve (Blue Cable)
B17	230V AC Live Output	Live Output to DHW Zone Valve (Brown Cable)
B18	230V AC Live Input	Live Output to Buffer Heating Zone Valve (Brown Cable)
B19	230V AC Neutral Output	Neutral Output to Time Clock (1.5mm ² cable)
B20	230V AC Live Output	Permanent Live to Time Clock (1.5mm ² cable)
B22	230V AC Live Input	Switch Live back from Time Clock for Heating Zone 1
B24	230V AC Live Input	Switch Live back from Time Clock for Heating Zone 2
F1	Comms	Communication to ODU
F2	Comms	Communication to ODU
V1	12V	12Vdc Output
V2	Gnd	Ground
F3	Gnd	Samsung Controller
F4	Gnd	Samsung Controller
Earths		Connected to Earth Bar

Commissioning, Service & Maintenance

Commissioning

From as little as £480 Inc VAT (Only applicable to UK)

Annual Servicing

All Samsung Air Source Heat Pumps supplied by Joule must be serviced annually to validate the product warranty under the terms of the EUW¹ agreement. Items that must be inspected annually to validate the warranty include,

- Check outdoor fan motor and lubricate if needed
- Check electrical wiring, contacts and terminals; repair as required
- Check all safety components
- Check compressor operation
- Check indoor thermostat operation
- Check defrost and heating modes (winter only)
- Check for excessive noise and vibration
- Check refrigerant charge
- Inspect air filters
- Check all safety and pressure switches
- Check motor and heaters/voltage/amperes

An annual service must be carried out by a suitable qualified engineer to validate the terms of the Joule EUW agreement.

¹ EUW = Extended Warranty Period

Service to Validate Warranty

Customer Name:			
Address line 1:			
City:		Country	
Post Code:		Email	

Outdoor Unit Model:		Serial No:	
Engineer Name:		Company	
Telephone:		Email	
Samsung certified Service Engineer?		Course year?	

Outdoor	Description	Comment
Outdoor unit	Check for undue noise and vibration	
Casings and panels	Inspect for damage and clean (ph. neutral cleaner)	
Casings and panels	Inspect for corrosion and treat as required	
Frame & mountings	Visual Inspection adjust as required & treat any corrosion	
Heat exchanger	Inspect for damage and clean fins	
Fan blade and motor	Inspect for damage, tighten fixings and clean blades	
Base & drainage	Inspect for damage, clean and check condensate drainage	
Isolator	Inspect and tighten all terminals	
Outdoor terminals	Inspect wiring connections and tighten all terminals	
Indoor Control Kit	Description	Comment
Isolator	Inspect and tighten all terminals	

Service to Validate Warranty

Indoor terminals	Inspect wiring connections and tighten all terminals	
------------------	--	--

System	Description	Comment
Wet circuit	Check pipe work insulation, repair as required	
Wet circuit	Clean strainers	
Wet circuit	Remove any trapped air in the system	
Wet circuit	Check / Charge expansion vessel	
Wet circuit	Check system water pressure is within limits	
Wet circuit	Check for signs of water leakage, repair as required	
Safety equipment	Test unvented safety equipment	
Glycol and inhibitor	Check concentration % and adjust as required, check for scale build-up or corrosion and treat as necessary	
Immersion heater	Inspect wiring connections and tighten all terminals	
Immersion heater	Check / record setting and test for correct operation	
2 Port Valves / 3-Way	Check for correct operation	

Operation	Description	Comment
Operation check	Check heat up performance in heating & DHW modes	
SNet Data	Check & update firmware	
	Check and record running data (Heating & DHW modes)	

Warranty

Standard Warranty Period And Extended Warranty Period

The warranty period starts on the date of installation as shown on the commissioning report. The standard warranty period ends 24 months later. By registering the product(s) which can be done either by yourself, or by the reseller from whom you have purchased the products (the “Reseller”) within 28 days after the installation date, you will receive an additional 5 year extended limited warranty service depending on the product type which will bring the total period of coverage to 7 years from the date of installation. All of the terms set in this Statement of Limited Warranty shall apply to any extended warranty. The method of service and operating conditions will be as described in the original warranty statement provided with the Samsung Product.

Warranty: Redemption Process & Details

1. This promotion cannot be used in conjunction with any other promotion(s) or special bid/tender pricing offered by Samsung Electronics.
2. This offer applies to models purchased after 00:01hrs (GMT) on 1st May 2016.
3. Upon registration the claimant will be sent an email confirmation with notification of registration and a related reference number for the claim being registered on.
4. A copy of your invoice and commissioning report MUST be submitted as proof of purchase.
5. Proof of dispatch will not be accepted as proof of receipt.
6. The 7 Year Extended Warranty is not transferable and no alternative will be offered.

Statement For Samsung

1. This offer only applies to the purchase of a new (not second-hand) Samsung air conditioning Product which is sold in the UK or ROI after 1st May 2016

Product	Model	Warranty Type
All EHS Product	various	7 years On Site

2. For customers outside the UK & ROI please refer to the country specific warranty information that came with your product.
3. All Extended Warranty Redemptions must be registered online within 28 days of installation.
4. This Promotion is only available to end user customers who are using the products for business purposes.
5. Employees or agents of Samsung or their families or households or anyone professionally connected to this promotion is not eligible.
6. By registering for the Extended Warranty you agree to be bound by these terms and conditions.

Warranty

Extent Of Warranty

During the extended warranty period Samsung continues to warrant that the Samsung Product shall be free from defects in materials and workmanship. If the relevant product does not function as warranted, against defective materials or workmanship, you should contact the Joule technical department or your local sales representative.

Samsung Maintenance Parts, Supplies and Optional accessories (i.e. consumables), supplied as part of the initial Samsung Product installation and listed in the Samsung Product User Guides, is warranted against defective materials or workmanship for the first 6 months, from date of Samsung Product purchase or recommended average life volume, whichever is achieved first, but is excluded from the Extended Warranty period.

When Warranty service involves the exchange of a product or part, subject to applicable law, the item replaced becomes the property of Samsung.

The replacement item assumes the remaining warranty period of the original product.

Before you present the product(s) for On Site (IH) warranty service you must:

- Ensure that the Product is available for Warranty repair, on Site at the registered address.

Claim(s) For Warranty Service

To obtain a Warranty service, you must:

- Contact the Joule technical department or your local sales representative.
- Provide the full product model code and serial number
- Provide proof of activated extended warranty and proof of annual maintenance contract as per the e-mail confirmation sent at the time of online warranty registration(s)
- Provide a clear fault description and carry out any diagnostics as advised
- Comply with any reasonable instructions from Samsung or an Authorised Service Centre to allow you to receive the warranty service

Transfer Of Product

If you transfer this product to another user, warranty service may be available to that user during the remainder of the standard 24 month warranty period, but not during any extended warranty period (i.e. the extended warranty is not transferable).

Exclusions

Samsung makes no representation or guarantee that the Samsung product(s) will operate uninterrupted or error free.

During the Extended Warranty Period, Samsung will only provide the Warranty in the UK and ROI.

Samsung is not responsible for paying any travel or delivery costs where the product is located outside the UK or ROI.

Services performed by Samsung in rectifying damage or defect caused as a result of any excluded conditions shall be subject to additional charges for labour, transportation and parts.

The Extended Warranty is only available if you have an ongoing maintenance contract in place with a maintenance provider approved by Samsung, under which the product(s) must be checked at least once a year by that maintenance provider.

Warranty Service is not available to you if the product you present is:

- Defaced
- Altered
- Damaged beyond repair, or
- In need of a repair not included in Warranty service. (e.g Periodic Maintenance, consumable replacement and the repair or replacement of parts due to normal wear and tear) transportation damage, or any other damage caused by external factors (i.e. not damage caused by issues inherent in the manufacturing of the product)
- Does not match Product Model and serial number details as registered for Warranty service

To the maximum extent permitted by law, warranty service does not include repair of failures caused by:

- Modification or attachments
- Accidents or misuse
- Unsuitable physical or operating environment
- Third party products, generic or refilled e.g. maintenance units or replacement parts
- Maintenance by anyone other than Joule or a Joule authorised service provider.
- Operation of a product beyond the limit of its duty cycle or Product specifications
- Products, components, parts, material, software, or interfaces not furnished by Samsung

Neither Samsung nor its third party suppliers or resellers make any other warranty, guarantee, or condition of any kind, whether express, implied, legal or statutory, with respect to the product(s), and to the extent permitted by applicable law, specifically disclaim any implied, legal or statutory warranties or conditions or merchantability, fitness for a particular, general or normal purpose, satisfactory quality, durability and warranties against latent defects.

General Terms Of Promotion

1. These terms and conditions are governed by English law and come under the English courts shall have exclusive jurisdiction to settle and resolve any dispute which may arise in connection with the validity, effect, interpretation and/or performance of these terms.
2. By registering for the extended warranty you agree to be bound by these terms and conditions.
3. The Promoter shall have the right, where necessary, to undertake all such action as is reasonable to protect

itself against fraudulent or invalid claim(s) including, without limitation, to require further verification as to the identity, and other relevant details of an entrant or claimant and/or the verification as to their qualifying purchase.

4. The Promoter shall not be liable for any interruption to this promotion whether due to force majeure or other factors beyond the Promoter's control.
5. The Promoter reserves the right, acting reasonably and in accordance with all relevant legislation and codes of practice, to vary the terms and conditions of this Promotion.
6. Promoter: Samsung Electronics (UK) Ltd, Samsung House, 1000 Hillwood Drive, Chertsey, Surrey, KT16 0PS. (Please do not send any Warranty applications to this address - they will not be registered for Warranty promotion)

Joule Cyclone

The **JOULE Cyclone** stainless steel vessel carries a fully transferable 25-year guarantee against faulty materials or manufacture provided that:

- It has been installed in the United Kingdom or the Republic of Ireland as per the instructions provided in the installation manual provided with the cylinder and in accordance with all of the relevant standards, regulations and codes of practice in force at the time.
- It has not been modified in any way, other than by JOULE
- It has not been misused, tampered with or subjected to neglect.
- The system is fed from the public mains water supply.
- It has only been used for the storage of potable water.
- It has not been subjected to frost damage.
- The unit has been serviced annually.
- The Service Log Book has been completed after each annual service.
- The warranty card is filled in and a copy is sent by email to warranty@joule.ie

Exclusions

The guarantee does not cover cylinders affected by the following;

- The effects of scale build up on the cylinder.
- Any labour charges associated with replacing the unit or its parts.
- Any consequential losses caused by the failure or malfunction of the unit.

Please note that invoices for servicing may be requested to prove that the unit has been serviced annually.

Unvented Kit & Other Components

The expansion vessel and cold water controls supplied with JOULE models carry a 1-year guarantee. All other components that are fitted to, or supplied, with the unit carry a 1-year guarantee.

Declaration of Conformity

Manufacturer

Samsung Electronics Co., Ltd.

Product details

Product : Combination heater and Package of Combination heater
Model(s) : AE050RXYDEG
Variant Model(s) : -

Declaration & Applicable standards

We hereby declare, that the product above is in compliance with the essential requirements of the Low Voltage Directive (2014/35/EU) and EMC Directive (2014/30/EU) and Pressure Equipment Directive(2014/68/EU) by application of :

EMC

EN 55014-1:2017
EN 55014-2:2015
EN 61000-3-3:2013
EN 61000-3-2:2014

PED

EN 14276-1:2006 +A1:2011
EN 14276-2:2007 +A1:2011
EN 13445-1:2014 +A1:2014
EN 13445-2:2014 +A2:2018
EN 13445-5:2014
EN 378-2:2016

Safety

EN 60335-1:2012 +A11:2014 +A13:2017
EN 60335-2-40:2003 +A11:2004 +A12:2005 +A1:2006 +A2:2009
+A13:2012
EN 62233:2008

and the Eco-Design Directive (2009/125/EC) implemented by Regulation (EU) No 813/2013 for space heaters and combination heaters using test methods from EN 14825:2016, EN 14511:2013 and EN 12102:2017 and the Directive (2011/65/EU) on the restriction of the use of certain hazardous substances in electrical and electronic equipment by application of EN 50581:2012

※ The Notified Body SGS, 1155 has reviewed the technical file for the Pressure Equipment Directive and has issued the Certificate No.: PTC18.09131.5120
Conformity assessment module D1 has been followed. This product is category II under the pressure equipment Directive 2014/68/EU

Representative in the EU

Samsung Electronics QA Lab.
Blackbushe Business Park
Saxony Way, Yateley, Hampshire
GU46 6GG, UK



2019-05-13

(Place and date of issue)

Stephen Colclough – Director Regulatory Affairs

(Name and signature of authorized person)

※ This is not the address of Samsung Service Centre. Please see the address or the phone number of Samsung Service Centre in the warranty card or contact the retailer where you purchased your product.

Declaration of Conformity

Manufacturer

Samsung Electronics Co., Ltd.

Product details

Product : Combination heater and Package of Combination heater
Model(s) : AE080RXYDEG
Variant Model(s) : -

Declaration & Applicable standards

We hereby declare, that the product above is in compliance with the essential requirements of the Low Voltage Directive (2014/35/EU) and EMC Directive (2014/30/EU) and Pressure Equipment Directive(2014/68/EU) by application of :

EMC

EN 55014-1:2017
EN 55014-2:2015
EN 61000-3-11:2008
EN 61000-3-12:2011

PED

EN 14276-1:2006 +A1:2011
EN 14276-2:2007 +A1:2011
EN 13445-1:2014 + A1:2014
EN 13445-2:2014 +A2:2018
EN 13445-5:2014
EN 378-2:2016

Safety

EN 60335-1:2012 +A11:2014 +A13:2017
EN 60335-2-40:2003 +A11:2004 +A12:2005 +A1:2006 +A2:2009
+A13:2012
EN 62233:2008

and the Eco-Design Directive (2009/125/EC) implemented by Regulation (EU) No 327/2011 for fans driven by motors using test methods from AMCA 210-07 and EN 60704-2-7:1997 and the Regulation (EU) No 813/2013 for space heaters and combination heaters using test methods from EN 14825:2016, EN 14511:2013 and EN 12102:2017 and the Directive (2011/65/EU) on the restriction of the use of certain hazardous substances in electrical and electronic equipment by application of EN 50581:2012

* The Notified Body TUV-NORD, 0045 has reviewed the technical file for the Pressure Equipment Directive and has issued the Certificate No.: 0045/202/9160/Z/00001/19/D/001(00)
Conformity assessment module D1 has been followed. This product is category II under the pressure equipment Directive 2014/68/EU

Signed on behalf of Samsung Electronics

Samsung Electronics QA Lab.
Blackbushe Business Park
Saxony Way, Yateley, Hampshire
GU46 6GG, UK

[Handwritten signature of Stephen Colclough]

2019-05-13

Stephen Colclough – Director Regulatory Affairs

(Place and date of issue)

(Name and signature of authorized person)

* This is not the address of Samsung Service Centre. Please see the address or the phone number of Samsung Service Centre in the warranty card or contact the retailer where you purchased your product.

Declaration of Conformity

Manufacturer

Samsung Electronics Co., Ltd.

Product details

Product : Combination heater and Package of Combination heater
Model(s) : AE160RXYDEG
Variant Model(s) : AE120RXYDEG

Declaration & Applicable standards

We hereby declare, that the product above is in compliance with the essential requirements of the Low Voltage Directive (2014/35/EU) and EMC Directive (2014/30/EU) and Pressure Equipment Directive(2014/68/EU) by application of :

EMC

EN 55014-1:2017
EN 55014-2:2015
EN 61000-3-11:2008
EN 61000-3-12:2011

PED

EN 14276-1:2006 +A1:2011
EN 14276-2:2007 +A1:2011
EN 13445-1:2014 + A1:2014
EN 13445-2:2014 +A2:2018
EN 13445-5:2014
EN 378-2:2016

Safety

EN 60335-1:2012 +A11:2014 +A13:2017
EN 60335-2-40:2003 +A11:2004 +A12:2005 +A1:2006 +A2:2009
+A13:2012
EN 62233:2008

and the Eco-Design Directive (2009/125/EC) implemented by Regulation (EU) No 327/2011 for fans driven by motors using test methods from AMCA 210-07 and EN 60704-2-7:1997 and the Regulation (EU) No 813/2013 for space heaters and combination heaters using test methods from EN 14825:2016, EN 14511:2013 and EN 12102:2017 and the Directive (2011/65/EU) on the restriction of the use of certain hazardous substances in electrical and electronic equipment by application of EN 50581:2012

* The Notified Body TUV-NORD, 0045 has reviewed the technical file for the Pressure Equipment Directive and has issued the Certificate No.: 0045/202/9160/Z/00001/19/D/001(00)
Conformity assessment module D1 has been followed. This product is category II under the pressure equipment Directive 2014/68/EU

Signed on behalf of Samsung Electronics

Samsung Electronics QA Lab.
Blackbushe Business Park
Saxony Way, Yateley, Hampshire
GU46 6GG, UK

[Handwritten signature of Stephen Colclough]

2019-05-22

Stephen Colclough – Director Regulatory Affairs

(Place and date of issue)

(Name and signature of authorized person)

* This is not the address of Samsung Service Centre. Please see the address or the phone number of Samsung Service Centre in the warranty card or contact the retailer where you purchased your product.



Declaration of Conformity

We, the manufacturer: Chewbay Ltd. T/A Joule Ireland
Unit 407 Northwest Business Park,
Cappagh Road, Dublin 11,
Ireland. D11 HD36

declare under our sole responsibility that the product:

Product: **Combination Heater and Package Combination Heater**
Product Reference: **AE050RXYDEG EU & Joule 200L H.G Cyclone**
AE080RXYDEG EU & Joule 200L H.G Cyclone
AE120RXYDEG EU & Joule 300L H.G Cyclone
AE160RXYDEG EU & Joule 300L H.G Cyclone

to which this declaration relates is in conformity with the essential requirements and other relevant requirements of Directive 2009/125/EC on the Ecodesign of energy related products. The product is in conformity with the following standards and/or other normative documents:

EN 14825: 2016, EN 14511: 2013,
EN 16147: 2017, EN 12102: 2013.

and that the product also complies with the provisions of the following European Directives:

Commission Delegated Regulation (EU) No 813/2013 supplementing Directive 2009/125/EC, Ecodesign requirements for space heaters and combination heaters.

In addition, those models which can be fitted with immersion heating elements, have been designed and built according to EN60335 European Standard concerning safety in electric appliances and similar equipment and comply with 2014/35/EU European Low Voltage Directive.

Place and date of issue:
Dublin, Ireland. 18th of December 2020

Signed by the manufacturer:

Name: Ian Barrett
Title: Director

Note: This declaration is only valid where no modifications have been made to the product and to the applicable legislation.

DoC identification number: 1018122020

ERP Information

COMMISSION REGULATION (EU) No. 813/2013

Information requirements for heat pump space heaters and heat pump combination heaters

Model: Samsung AE050RXYDEG EU & Joule 200L H.G Cyclone

Air-to-water heat pump: Yes

Water-to-water heat pump: No

Brine-to-water heat pump: No

Low-temperature heat pump: No

Equipped with supplementary heater: No

Heat pump combination heater: Yes

Parameters are declared for: Low-temp application, 35°C

Parameters are declared for: **Average climate conditions**

Item	Symbol	Value	Unit
Rated heat output (*)	<i>Prated</i>	6	kW
Declared capacity for heating for part load at indoor temperature 20°C and outdoor temperature T_j			
$T_j = -7^\circ\text{C}$	<i>Pdh</i>	4.9	kW
$T_j = +2^\circ\text{C}$	<i>Pdh</i>	3.0	kW
$T_j = +7^\circ\text{C}$	<i>Pdh</i>	1.9	kW
$T_j = +12^\circ\text{C}$	<i>Pdh</i>	1.9	kW
$T_j = \text{bivalent temperature}$	<i>Pdh</i>	4.9	kW
$T_j = \text{operation limit temperature}$	<i>Pdh</i>	4.6	kW
For air-to-water heat pumps: $T_j = -15^\circ\text{C}$ (if TOL, -20°C)	<i>Pdh</i>	-	kW
Bivalent temperature	<i>Tbiv</i>	-7	°C
Cycling interval capacity for heating	<i>Pcyc</i>	-	kW
Degradation co-efficient (**)	<i>Cdh</i>	0.9	-
Power consumption in modes other than active mode			
Off mode	<i>Poff</i>	0.022	kW
Thermostat-off mode	<i>Pto</i>	0.022	kW
Standby mode	<i>Psa</i>	0.022	kW
Crankcase heater mode	<i>Pck</i>	0.000	kW
Other items			
Capacity control	Variable		
Sound power level, indoors/outdoors	<i>LWA</i>	-/63	dB
Emissions of nitrogen oxides	<i>NOx</i>	-	mg/kWh

For heat pump combination heater:

Declared load profile	-		
Daily electricity consumption	<i>Q_elec</i>	-	kWh

Contact details: Joule Ireland, Unit 407 North West Business Park, Cappagh Road, Dublin 11, Ireland. D11 HD36

(*) For heat pump space heaters and heat pump combination heaters, the rated heat output *Prated* is equal to the design load for heating *Pdesignh*, and the rated output of a supplementary heater *Psup* is equal to the supplementary capacity for heating *sup(Tj)*.

(**) If *Cdh* is not determined by measurement then the default degradation coefficient is *Cdh* = 0.9.



Applicable Standards:

EN14511: 2013, EN14825: 2016, EN 16147: 2017, EN12102: 2017

Item	Symbol	Value	Unit
Seasonal space heating energy efficiency	$\eta_{s,h}$	175	%
Declared coefficient of performance for part load at indoor temperature 20°C and outdoor temperature T_j			
$T_j = -7^\circ\text{C}$	<i>COPd</i>	2.99	-
$T_j = +2^\circ\text{C}$	<i>COPd</i>	4.18	-
$T_j = +7^\circ\text{C}$	<i>COPd</i>	6.11	-
$T_j = +12^\circ\text{C}$	<i>COPd</i>	7.70	-
$T_j = \text{bivalent temperature}$	<i>COPd</i>	2.99	-
$T_j = \text{operation limit temperature}$	<i>COPd</i>	2.74	-
For air-to-water heat pumps: $T_j = -15^\circ\text{C}$ (if TOL, -20°C)	<i>Pdh</i>	-	-
For air-to-water heat pumps: Operation limit temperature	<i>TOL</i>	-10	°C
Cycling interval efficiency	<i>COPcyc</i>	-	-
Heating water operating limit temperature	<i>WTOL</i>	65	°C
Supplementary heater			
Rated heat output (**)	<i>Psup</i>	-	kW
Type of energy input			
For air-to-water heat pumps: Rated air flow rate, outdoors	-	3060	m ³ /h
For water- or brine-to-water heat pumps: Rated brine or water flow rate, outdoor heat exchanger	-	-	m ³ /h

Water heating energy efficiency	η_{wh}	-	%
Daily fuel consumption	<i>Q_fuel</i>	-	kWh

Applicable date: 17/12/2020

Revision: 2.0

ERP Information

COMMISSION REGULATION (EU) No. 813/2013

Information requirements for heat pump space heaters and heat pump combination heaters

Model: Samsung AE050RXYDEG EU & Joule 200L H.G Cyclone

Air-to-water heat pump: Yes

Water-to-water heat pump: No

Brine-to-water heat pump: No

Low-temperature heat pump: No

Equipped with supplementary heater: No

Heat pump combination heater: Yes

Parameters are declared for: Medium-temp application, 55°C

Parameters are declared for: **Average climate conditions**

Item	Symbol	Value	Unit
Rated heat output (*)	<i>Prated</i>	5	kW
Declared capacity for heating for part load at indoor temperature 20°C and outdoor temperature T_j			
$T_j = -7^\circ\text{C}$	<i>Pdh</i>	4.4	kW
$T_j = +2^\circ\text{C}$	<i>Pdh</i>	2.7	kW
$T_j = +7^\circ\text{C}$	<i>Pdh</i>	1.7	kW
$T_j = +12^\circ\text{C}$	<i>Pdh</i>	1.7	kW
$T_j = \text{bivalent temperature}$	<i>Pdh</i>	4.4	kW
$T_j = \text{operation limit temperature}$	<i>Pdh</i>	4.2	kW
For air-to-water heat pumps: $T_j = -15^\circ\text{C}$ (if TOL, -20°C)	<i>Pdh</i>	-	kW
Bivalent temperature	<i>Tbiv</i>	-7	°C
Cycling interval capacity for heating	<i>Pcyc</i>	-	kW
Degradation co-efficient (**)	<i>Cdh</i>	0.9	-
Power consumption in modes other than active mode			
Off mode	<i>Poff</i>	0.022	kW
Thermostat-off mode	<i>Pto</i>	0.022	kW
Standby mode	<i>Psa</i>	0.022	kW
Crankcase heater mode	<i>Pcr</i>	0.000	kW
Other items			
Capacity control	Variable		
Sound power level, indoors/outdoors	<i>LWA</i>	-/63	dB
Emissions of nitrogen oxides	<i>NOx</i>	-	mg/kWh

For heat pump combination heater:

Declared load profile	L		
Daily electricity consumption	Q_{elec}	3.420	kWh
Annual electricity consumption	AEC	692	kWh
Cylinder: Standby heat loss	-	2.064	kWh/day

Contact details: Joule Ireland, Unit 407 North West Business Park, Cappagh Road, Dublin 11, Ireland. D11 HD36

(*) For heat pump space heaters and heat pump combination heaters, the rated heat output *Prated* is equal to the design load for heating *Pdesignh*, and the rated output of a supplementary heater *Psup* is equal to the supplementary capacity for heating *sup(Tj)*.

(**) If *Cdh* is not determined by measurement then the default degradation coefficient is *Cdh*=0.9.



Applicable Standards:

EN14511: 2013, EN14825: 2016, EN 16147: 2017, EN12102: 2017

Item	Symbol	Value	Unit
Seasonal space heating energy efficiency	η_s	125	%
Declared coefficient of performance for part load at indoor temperature 20°C and outdoor temperature T_j			
$T_j = -7^\circ\text{C}$	<i>COPd</i>	2.16	-
$T_j = +2^\circ\text{C}$	<i>COPd</i>	3.17	-
$T_j = +7^\circ\text{C}$	<i>COPd</i>	4.03	-
$T_j = +12^\circ\text{C}$	<i>COPd</i>	4.73	-
$T_j = \text{bivalent temperature}$	<i>COPd</i>	2.16	-
$T_j = \text{operation limit temperature}$	<i>COPd</i>	2.00	-
For air-to-water heat pumps: $T_j = -15^\circ\text{C}$ (if TOL, -20°C)	<i>Pdh</i>	-	-
For air-to-water heat pumps: Operation limit temperature	TOL	-10	°C
Cycling interval efficiency	<i>COPcyc</i>	-	-
Heating water operating limit temperature	WTOL	65	°C
Supplementary heater			
Rated heat output (**)	P_{sup}	-	kW
Type of energy input			
For air-to-water heat pumps: Rated air flow rate, outdoors	-	3060	m ³ /h
For water- or brine-to-water heat pumps: Rated brine or water flow rate, outdoor heat exchanger	-	-	m ³ /h

Applicable date: 17/12/2020

Revision: 4.0

ERP Information

COMMISSION REGULATION (EU) No. 813/2013

Information requirements for heat pump space heaters and heat pump combination heaters

Model: Samsung AE080RYDEG EU & Joule 200L H.G Cyclone

Air-to-water heat pump: Yes

Water-to-water heat pump: No

Brine-to-water heat pump: No

Low-temperature heat pump: No

Equipped with supplementary heater: No

Heat pump combination heater: Yes

Parameters are declared for: Low-temp application, 35°C

Parameters are declared for: **Average climate conditions**

Item	Symbol	Value	Unit
Rated heat output (*)	<i>Prated</i>	8	kW
Declared capacity for heating for part load at indoor temperature 20°C and outdoor temperature T_j			
$T_j = -7^\circ\text{C}$	<i>Pdh</i>	7.1	kW
$T_j = +2^\circ\text{C}$	<i>Pdh</i>	4.3	kW
$T_j = +7^\circ\text{C}$	<i>Pdh</i>	3.1	kW
$T_j = +12^\circ\text{C}$	<i>Pdh</i>	2.6	kW
$T_j = \text{bivalent temperature}$	<i>Pdh</i>	7.1	kW
$T_j = \text{operation limit temperature}$	<i>Pdh</i>	7.0	kW
For air-to-water heat pumps: $T_j = -15^\circ\text{C}$ (if TOL, -20°C)	<i>Pdh</i>	-	kW
Bivalent temperature	<i>Tbiv</i>	-7	°C
Cycling interval capacity for heating	<i>Pcyc</i>	-	kW
Degradation co-efficient (**)	<i>Cdh</i>	0.9	-
Power consumption in modes other than active mode			
Off mode	<i>P_{off}</i>	0.022	kW
Thermostat-off mode	<i>P_{TD}</i>	0.022	kW
Standby mode	<i>P_{SB}</i>	0.022	kW
Crankcase heater mode	<i>P_{CK}</i>	0.000	kW
Other items			
Capacity control	Variable		
Sound power level, indoors/outdoors	<i>L_{WA}</i>	-63	dB
Emissions of nitrogen oxides	<i>NO_x</i>	-	mg/kWh

For heat pump combination heater:

Declared load profile	-		
Daily electricity consumption	<i>Q_{elec}</i>	-	kWh

Contact details: Joule Ireland, Unit 407 North West Business Park, Cappagh Road, Dublin 11, Ireland. D11 HD36

(*) For heat pump space heaters and heat pump combination heaters, the rated heat output *Prated* is equal to the design load for heating *Pdesignh*, and the rated output of a supplementary heater *Psup* is equal to the supplementary capacity for heating *sup(Tj)*.

(**) If *Cdh* is not determined by measurement then the default degradation coefficient is *Cdh* = 0.9.



Applicable Standards:

EN14511: 2013, EN14825: 2016, EN 16147: 2017, EN12102: 2017

Item	Symbol	Value	Unit
Seasonal space heating energy efficiency	η_s	175	%
Declared coefficient of performance for part load at indoor temperature 20°C and outdoor temperature T_j			
$T_j = -7^\circ\text{C}$	<i>COPd</i>	2.63	-
$T_j = +2^\circ\text{C}$	<i>COPd</i>	4.24	-
$T_j = +7^\circ\text{C}$	<i>COPd</i>	6.39	-
$T_j = +12^\circ\text{C}$	<i>COPd</i>	8.22	-
$T_j = \text{bivalent temperature}$	<i>COPd</i>	2.63	-
$T_j = \text{operation limit temperature}$	<i>COPd</i>	2.48	-
For air-to-water heat pumps: $T_j = -15^\circ\text{C}$ (if TOL, -20°C)	<i>Pdh</i>	-	-
For air-to-water heat pumps: Operation limit temperature	TOL	-10	°C
Cycling interval efficiency	<i>COPcyc</i>	-	-
Heating water operating limit temperature	WTOL	65	°C
Supplementary heater			
Rated heat output (**)	<i>P_{sup}</i>	-	kW
Type of energy input			
For air-to-water heat pumps: Rated air flow rate, outdoors		3960	m ³ /h
For water- or brine-to-water heat pumps: Rated brine or water flow rate, outdoor heat exchanger		-	m ³ /h

Water heating energy efficiency	η_{wh}	-	%
Daily fuel consumption	<i>Q_{fuel}</i>	-	kWh

Applicable date: 17/12/2020

Revision: 2.0

ERP Information

COMMISSION REGULATION (EU) No. 813/2013

Information requirements for heat pump space heaters and heat pump combination heaters

Model: Samsung AE080RXYDEG EU & Joule 200L H.G Cyclone

Air-to-water heat pump: Yes

Water-to-water heat pump: No

Brine-to-water heat pump: No

Low-temperature heat pump: No

Equipped with supplementary heater: No

Heat pump combination heater: Yes

Parameters are declared for: Medium-temp application, 55°C

Parameters are declared for: **Average climate conditions**

Item	Symbol	Value	Unit
Rated heat output (*)	<i>Prated</i>	8	kW
Declared capacity for heating for part load at indoor temperature 20°C and outdoor temperature T_j			
$T_j = -7^\circ\text{C}$	<i>Pdh</i>	7.1	kW
$T_j = +2^\circ\text{C}$	<i>Pdh</i>	4.3	kW
$T_j = +7^\circ\text{C}$	<i>Pdh</i>	2.8	kW
$T_j = +12^\circ\text{C}$	<i>Pdh</i>	2.4	kW
$T_j = \text{bivalent temperature}$	<i>Pdh</i>	7.1	kW
$T_j = \text{operation limit temperature}$	<i>Pdh</i>	6.8	kW
For air-to-water heat pumps: $T_j = -15^\circ\text{C}$ (if TOL, -20°C)	<i>Pdh</i>	-	kW
Bivalent temperature	<i>Tbiv</i>	-7	°C
Cycling interval capacity for heating	<i>Pcyc</i>	-	kW
Degradation co-efficient (**)	<i>Cdh</i>	0.9	-
Power consumption in modes other than active mode			
Off mode	<i>Poff</i>	0.022	kW
Thermostat-off mode	<i>Pto</i>	0.022	kW
Standby mode	<i>Psa</i>	0.022	kW
Crankcase heater mode	<i>Pcc</i>	0.000	kW
Other items			
Capacity control	Variable		
Sound power level, indoors/outdoors	<i>Lwa</i>	-/63	dB
Emissions of nitrogen oxides	<i>NOx</i>	-	mg/kWh

For heat pump combination heater:

Declared load profile	L		
Daily electricity consumption	<i>Qdec</i>	3.654	kWh
Annual electricity consumption	<i>AEC</i>	729	kWh
Cylinder: Standby heat loss	-	2.064	kWh/day

Contact details

Joule Ireland, Unit 407 North West Business Park, Cappagh Road, Dublin 11, Ireland. D11 HD36

(*) For heat pump space heaters and heat pump combination heaters, the rated heat output *Prated* is equal to the design load for heating *Pdesignh*, and the rated output of a supplementary heater *Psup* is equal to the supplementary capacity for heating *sup(Tj)*.

(**) If *Cdh* is not determined by measurement then the default degradation coefficient is *Cdh* = 0.9.



SAMSUNG

Applicable Standards:

EN14511: 2013, EN14825: 2016, EN 16147: 2017, EN12102: 2017

Item	Symbol	Value	Unit
Seasonal space heating energy efficiency	η_s	126	%
Declared coefficient of performance for part load at indoor temperature 20°C and outdoor temperature T_j			
$T_j = -7^\circ\text{C}$	<i>COPd</i>	1.90	-
$T_j = +2^\circ\text{C}$	<i>COPd</i>	3.11	-
$T_j = +7^\circ\text{C}$	<i>COPd</i>	4.55	-
$T_j = +12^\circ\text{C}$	<i>COPd</i>	5.77	-
$T_j = \text{bivalent temperature}$	<i>COPd</i>	1.90	-
$T_j = \text{operation limit temperature}$	<i>COPd</i>	1.66	-
For air-to-water heat pumps: $T_j = -15^\circ\text{C}$ (if TOL, -20°C)	<i>Pdh</i>	-	-
For air-to-water heat pumps: Operation limit temperature	<i>TOL</i>	-10	°C
Cycling interval efficiency	<i>COPcyc</i>	-	-
Heating water operating limit temperature	<i>WTOL</i>	65	°C
Supplementary heater			
Rated heat output (**)	<i>Psup</i>	-	kW
Type of energy input			
For air-to-water heat pumps: Rated air flow rate, outdoors	-	3960	m ³ /h
For water- or brine-to-water heat pumps: Rated brine or water flow rate, outdoor heat exchanger	-	-	m ³ /h

Applicable date: 27/07/2020

Revision: 2.0

ERP Information

COMMISSION REGULATION (EU) No. 813/2013

Information requirements for heat pump space heaters and heat pump combination heaters

Model: Samsung AE120RXYDEG EU & Joule 300L H.G Cyclone

Air-to-water heat pump: Yes

Water-to-water heat pump: No

Brine-to-water heat pump: No

Low-temperature heat pump: No

Equipped with supplementary heater: No

Heat pump combination heater: Yes

Parameters are declared for: Low-temp application, 35°C

Parameters are declared for: **Average climate conditions**

Item	Symbol	Value	Unit
Rated heat output (*)	<i>Prated</i>	13	kW
Declared capacity for heating for part load at indoor temperature 20°C and outdoor temperature T_j			
$T_j = -7^\circ\text{C}$	<i>Pdh</i>	11.5	kW
$T_j = +2^\circ\text{C}$	<i>Pdh</i>	7.0	kW
$T_j = +7^\circ\text{C}$	<i>Pdh</i>	5.6	kW
$T_j = +12^\circ\text{C}$	<i>Pdh</i>	4.8	kW
$T_j = \text{bivalent temperature}$	<i>Pdh</i>	11.5	kW
$T_j = \text{operation limit temperature}$	<i>Pdh</i>	13.0	kW
For air-to-water heat pumps: $T_j = -15^\circ\text{C}$ (if $TOL_{-20^\circ\text{C}}$)	<i>Pdh</i>	-	kW
Bivalent temperature	<i>Tbiv</i>	-7	°C
Cycling interval capacity for heating	<i>Pcych</i>	-	kW
Degradation co-efficient (**)	<i>Cdh</i>	0.9	-
Power consumption in modes other than active mode			
Off mode	<i>P_{off}</i>	0.022	kW
Thermostat-off mode	<i>P_{to}</i>	0.022	kW
Standby mode	<i>P_{sa}</i>	0.022	kW
Crankcase heater mode	<i>P_{ck}</i>	0.000	kW
Other items			
Capacity control	Variable		
Sound power level, indoors/outdoors	<i>L_{wa}</i>	-/64	dB
Emissions of nitrogen oxides	<i>NO_x</i>	-	mg/kWh

For heat pump combination heater:

Declared load profile	-		
Daily electricity consumption	<i>Q_{elec}</i>	-	kWh

Contact details: Joule Ireland, Unit 407 North West Business Park, Cappagh Road, Dublin 11, Ireland. D11 HD36

(*) For heat pump space heaters and heat pump combination heaters, the rated heat output *Prated* is equal to the design load for heating *Pdesignh*, and the rated output of a supplementary heater *Psup* is equal to the supplementary capacity for heating *sup(Tj)*.

(**) If *Cdh* is not determined by measurement then the default degradation coefficient is *Cdh*=0.9.



SAMSUNG

Applicable Standards:

EN14511: 2013, EN14825: 2016, EN 16147: 2017, EN12102: 2017

Item	Symbol	Value	Unit
Seasonal space heating energy efficiency	η_s	185	%
Declared coefficient of performance for part load at indoor temperature 20°C and outdoor temperature T_j			
$T_j = -7^\circ\text{C}$	<i>COPd</i>	2.71	-
$T_j = +2^\circ\text{C}$	<i>COPd</i>	4.48	-
$T_j = +7^\circ\text{C}$	<i>COPd</i>	6.86	-
$T_j = +12^\circ\text{C}$	<i>COPd</i>	8.95	-
$T_j = \text{bivalent temperature}$	<i>COPd</i>	2.71	-
$T_j = \text{operation limit temperature}$	<i>COPd</i>	2.37	-
For air-to-water heat pumps: $T_j = -15^\circ\text{C}$ (if $TOL_{-20^\circ\text{C}}$)	<i>Pdh</i>	-	-
For air-to-water heat pumps: Operation limit temperature	<i>TOL</i>	-10	°C
Cycling interval efficiency	<i>COP_{ych}</i>	-	-
Heating water operating limit temperature	<i>WTOL</i>	65	°C
Supplementary heater			
Rated heat output (**)	<i>P_{sup}</i>	-	kW
Type of energy input			
For air-to-water heat pumps: Rated air flow rate, outdoors		5940	m ³ /h
For water- or brine-to-water heat pumps: Rated brine or water flow rate, outdoor heat exchanger		-	m ³ /h

Water heating energy efficiency	η_{wh}	-	%
Daily fuel consumption	<i>Q_{fuel}</i>	-	kWh

Applicable date: 17/12/2020

Revision: 2.0

ERP Information

COMMISSION REGULATION (EU) No. 813/2013

Information requirements for heat pump space heaters and heat pump combination heaters

Model: Samsung AE120RXYDEG EU & Joule 300L H.G Cyclone

Air-to-water heat pump: Yes

Water-to-water heat pump: No

Brine-to-water heat pump: No

Low-temperature heat pump: No

Equipped with supplementary heater: No

Heat pump combination heater: Yes

Parameters are declared for: Medium-temp application, 55°C

Parameters are declared for: **Average climate conditions**

Item	Symbol	Value	Unit
Rated heat output (*)	<i>Prated</i>	12	kW
Declared capacity for heating for part load at indoor temperature 20°C and outdoor temperature T_j			
$T_j = -7^\circ\text{C}$	<i>Pdh</i>	10.6	kW
$T_j = +2^\circ\text{C}$	<i>Pdh</i>	6.5	kW
$T_j = +7^\circ\text{C}$	<i>Pdh</i>	4.2	kW
$T_j = +12^\circ\text{C}$	<i>Pdh</i>	4.2	kW
$T_j = \text{bivalent temperature}$	<i>Pdh</i>	10.6	kW
$T_j = \text{operation limit temperature}$	<i>Pdh</i>	12.0	kW
For air-to-water heat pumps: $T_j = -15^\circ\text{C}$ (if TOL, -20°C)	<i>Pdh</i>	-	kW
Bivalent temperature	<i>Tbiv</i>	-7	°C
Cycling interval capacity for heating	<i>Pcyc</i>	-	kW
Degradation co-efficient (**)	<i>Cdh</i>	0.9	-
Power consumption in modes other than active mode			
Off mode	<i>Poff</i>	0.022	kW
Thermostat-off mode	<i>Pto</i>	0.022	kW
Standby mode	<i>Psa</i>	0.022	kW
Crankcase heater mode	<i>Pcc</i>	0.000	kW
Other items			
Capacity control	Variable		
Sound power level, indoors/outdoors	<i>Lwa</i>	-/64	dB
Emissions of nitrogen oxides	<i>NOx</i>	-	mg/kWh

For heat pump combination heater:

Declared load profile	XL		
Daily electricity consumption	Q_{elec}	6.822	kWh
Annual electricity consumption	<i>AEC</i>	1393	kWh
Cylinder: Standby heat loss	-	2.352	kWh/day

Contact details

Joule Ireland, Unit 407 North West Business Park, Cappagh Road, Dublin 11, Ireland. D11 HD36

(*) For heat pump space heaters and heat pump combination heaters, the rated heat output *Prated* is equal to the design load for heating *Pdesignh*, and the rated output of a supplementary heater *Psup* is equal to the supplementary capacity for heating *sup(Tj)*.

(**) If *Cdh* is not determined by measurement then the default degradation coefficient is *Cdh* = 0.9.



SAMSUNG

Applicable Standards:

EN14511: 2013, EN14825: 2016, EN 16147: 2017, EN12102: 2017

Item	Symbol	Value	Unit
Seasonal space heating energy efficiency	η_s	138	%
Declared coefficient of performance for part load at indoor temperature 20°C and outdoor temperature T_j			
$T_j = -7^\circ\text{C}$	<i>COPd</i>	2.16	-
$T_j = +2^\circ\text{C}$	<i>COPd</i>	3.45	-
$T_j = +7^\circ\text{C}$	<i>COPd</i>	4.57	-
$T_j = +12^\circ\text{C}$	<i>COPd</i>	6.12	-
$T_j = \text{bivalent temperature}$	<i>COPd</i>	2.16	-
$T_j = \text{operation limit temperature}$	<i>COPd</i>	1.96	-
For air-to-water heat pumps: $T_j = -15^\circ\text{C}$ (if TOL, -20°C)	<i>Pdh</i>	-	-
For air-to-water heat pumps: Operation limit temperature	<i>TOL</i>	-10	°C
Cycling interval efficiency	<i>COPcyc</i>	-	-
Heating water operating limit temperature	<i>WTOL</i>	65	°C
Supplementary heater			
Rated heat output (**)	P_{sup}	-	kW
Type of energy input			
For air-to-water heat pumps: Rated air flow rate, outdoors		5940	m ³ /h
For water- or brine-to-water heat pumps: Rated brine or water flow rate, outdoor heat exchanger		-	m ³ /h

Applicable date: 17/12/2020

Revision: 2.0

ERP Information

COMMISSION REGULATION (EU) No. 813/2013

Information requirements for heat pump space heaters and heat pump combination heaters

Model: Samsung AE160RXYDEG EU & Joule 300L H.G Cyclone

Air-to-water heat pump: Yes

Water-to-water heat pump: No

Brine-to-water heat pump: No

Low-temperature heat pump: No

Equipped with supplementary heater: No

Heat pump combination heater: Yes

Parameters are declared for: Low-temp application, 35°C

Parameters are declared for: **Average climate conditions**

Item	Symbol	Value	Unit
Rated heat output (*)	<i>Prated</i>	16	kW
Declared capacity for heating for part load at indoor temperature 20°C and outdoor temperature T_j			
$T_j = -7^\circ\text{C}$	<i>Pdh</i>	14.2	kW
$T_j = +2^\circ\text{C}$	<i>Pdh</i>	8.6	kW
$T_j = +7^\circ\text{C}$	<i>Pdh</i>	5.5	kW
$T_j = +12^\circ\text{C}$	<i>Pdh</i>	5.2	kW
$T_j = \text{bivalent temperature}$	<i>Pdh</i>	14.2	kW
$T_j = \text{operation limit temperature}$	<i>Pdh</i>	13.8	kW
For air-to-water heat pumps: $T_j = -15^\circ\text{C}$ (if $TOL_{-20^\circ\text{C}}$)	<i>Pdh</i>	-	kW
Bivalent temperature	<i>Tbiv</i>	-7	°C
Cycling interval capacity for heating	<i>Pcyc</i>	-	kW
Degradation co-efficient (**)	<i>Cdh</i>	0.9	-
Power consumption in modes other than active mode			
Off mode	<i>P_{off}</i>	0.022	kW
Thermostat-off mode	<i>P_{to}</i>	0.022	kW
Standby mode	<i>P_{sa}</i>	0.022	kW
Crankcase heater mode	<i>P_{ck}</i>	0.000	kW
Other items			
Capacity control	Variable		
Sound power level, indoors/outdoors	<i>L_{wa}</i>	-/66	dB
Emissions of nitrogen oxides	<i>NO_x</i>	-	mg/kWh

For heat pump combination heater:

Declared load profile	-		
Daily electricity consumption	<i>Q_{elec}</i>	-	kWh

Contact details: Joule Ireland, Unit 407 North West Business Park, Cappagh Road, Dublin 11, Ireland. D11 HD36

(*) For heat pump space heaters and heat pump combination heaters, the rated heat output *Prated* is equal to the design load for heating *Pdesignh*, and the rated output of a supplementary heater *Psup* is equal to the supplementary capacity for heating *sup(Tj)*.

(**) If *Cdh* is not determined by measurement then the default degradation coefficient is *Cdh* = 0.9.



SAMSUNG

Applicable Standards:

EN14511: 2013, EN14825: 2016, EN 16147: 2017, EN12102: 2017

Item	Symbol	Value	Unit
Seasonal space heating energy efficiency	η_s	176	%
Declared coefficient of performance for part load at indoor temperature 20°C and outdoor temperature T_j			
$T_j = -7^\circ\text{C}$	<i>COPd</i>	2.65	-
$T_j = +2^\circ\text{C}$	<i>COPd</i>	4.11	-
$T_j = +7^\circ\text{C}$	<i>COPd</i>	6.86	-
$T_j = +12^\circ\text{C}$	<i>COPd</i>	8.81	-
$T_j = \text{bivalent temperature}$	<i>COPd</i>	2.65	-
$T_j = \text{operation limit temperature}$	<i>COPd</i>	2.37	-
For air-to-water heat pumps: $T_j = -15^\circ\text{C}$ (if $TOL_{-20^\circ\text{C}}$)	<i>Pdh</i>	-	-
For air-to-water heat pumps: Operation limit temperature	<i>TOL</i>	-10	°C
Cycling interval efficiency	<i>COPcyc</i>	-	-
Heating water operating limit temperature	<i>WTOL</i>	65	°C
Supplementary heater			
Rated heat output (**)	<i>P_{sup}</i>	-	kW
Type of energy input			
For air-to-water heat pumps: Rated air flow rate, outdoors		7080	m ³ /h
For water- or brine-to-water heat pumps: Rated brine or water flow rate, outdoor heat exchanger		-	m ³ /h

Water heating energy efficiency	η_{wh}	-	%
Daily fuel consumption	<i>Q_{fuel}</i>	-	kWh

Applicable date: 17/12/2020

Revision: 2.0

ERP Information

COMMISSION REGULATION (EU) No. 813/2013

Information requirements for heat pump space heaters and heat pump combination heaters

Model: Samsung AE160RXYDEG EU & Joule 300L H.G Cyclone

Air-to-water heat pump: Yes

Water-to-water heat pump: No

Brine-to-water heat pump: No

Low-temperature heat pump: No

Equipped with supplementary heater: No

Heat pump combination heater: Yes

Parameters are declared for: Medium-temp application, 55°C

Parameters are declared for: **Average climate conditions**

Item	Symbol	Value	Unit
Rated heat output (*)	<i>Prated</i>	16	kW
Declared capacity for heating for part load at indoor temperature 20°C and outdoor temperature T_j			
$T_j = -7^\circ\text{C}$	<i>Pdh</i>	14.2	kW
$T_j = +2^\circ\text{C}$	<i>Pdh</i>	8.6	kW
$T_j = +7^\circ\text{C}$	<i>Pdh</i>	5.5	kW
$T_j = +12^\circ\text{C}$	<i>Pdh</i>	4.5	kW
$T_j = \text{bivalent temperature}$	<i>Pdh</i>	14.2	kW
$T_j = \text{operation limit temperature}$	<i>Pdh</i>	14.0	kW
For air-to-water heat pumps: $T_j = -15^\circ\text{C}$ (if TOL, -20°C)	<i>Pdh</i>	-	kW
Bivalent temperature	<i>Tbiv</i>	-7	°C
Cycling interval capacity for heating	<i>Pcyc</i>	-	kW
Degradation co-efficient (**)	<i>Cdh</i>	0.9	-
Power consumption in modes other than active mode			
Off mode	<i>Poff</i>	0.022	kW
Thermostat-off mode	<i>Pto</i>	0.022	kW
Standby mode	<i>Psa</i>	0.022	kW
Crankcase heater mode	<i>Pcx</i>	0.000	kW
Other items			
Capacity control	Variable		
Sound power level, indoors/outdoors	<i>Lwa</i>	-/66	dB
Emissions of nitrogen oxides	<i>NOx</i>	-	mg/kWh

For heat pump combination heater:

Declared load profile	XL		
Daily electricity consumption	<i>Qdec</i>	6.247	kWh
Annual electricity consumption	<i>AEC</i>	1245	kWh
Cylinder: Standby heat loss	-	2.352	kWh/day

Contact details

Joule Ireland, Unit 407 North West Business Park, Cappagh Road, Dublin 11, Ireland. D11 HD36

(*) For heat pump space heaters and heat pump combination heaters, the rated heat output *Prated* is equal to the design load for heating *Pdesignh*, and the rated output of a supplementary heater *Psup* is equal to the supplementary capacity for heating *sup(Tj)*.

(**) If *Cdh* is not determined by measurement then the default degradation coefficient is *Cdh* = 0.9.



SAMSUNG

Applicable Standards:

EN14511: 2013, EN14825: 2016, EN 16147: 2017, EN12102: 2017

Item	Symbol	Value	Unit
Seasonal space heating energy efficiency	η_s	138	%
Declared coefficient of performance for part load at indoor temperature 20°C and outdoor temperature T_j			
$T_j = -7^\circ\text{C}$	<i>COPd</i>	2.06	-
$T_j = +2^\circ\text{C}$	<i>COPd</i>	3.31	-
$T_j = +7^\circ\text{C}$	<i>COPd</i>	5.23	-
$T_j = +12^\circ\text{C}$	<i>COPd</i>	6.57	-
$T_j = \text{bivalent temperature}$	<i>COPd</i>	2.06	-
$T_j = \text{operation limit temperature}$	<i>COPd</i>	1.82	-
For air-to-water heat pumps: $T_j = -15^\circ\text{C}$ (if TOL, -20°C)	<i>Pdh</i>	-	-
For air-to-water heat pumps: Operation limit temperature	<i>TOL</i>	-10	°C
Cycling interval efficiency	<i>COPcyc</i>	-	-
Heating water operating limit temperature	<i>WTOL</i>	65	°C
Supplementary heater			
Rated heat output (**)	<i>Psup</i>	-	kW
Type of energy input			
For air-to-water heat pumps: Rated air flow rate, outdoors	-	7080	m ³ /h
For water- or brine-to-water heat pumps: Rated brine or water flow rate, outdoor heat exchanger	-	-	m ³ /h

Applicable date: 17/12/2020

Revision: 2.0

ERP Information

COMMISSION DELEGATED REGULATION (EU) No 811/2013 PRODUCT FICHE (ENERGY LABELLING OF COMBINATION HEATER)



Supplier's name or trademark		-	Samsung Electronics Co, Ltd. & Joule Ireland			
B	Supplier's model identifier	-	AE050RYDEG EU & Joule 200L H.G Cyclone	AE080RYDEG EU & Joule 200L H.G Cyclone	AE120RYDEG EU & Joule 300L H.G Cyclone	AE160RYDEG EU & Joule 300L H.G Cyclone
C	For space heating	-	Medium-temperature application			
E	For water heating	Load profile	L	L	XL	XL
G	Seasonal space heating energy efficiency class	Medium-temperature	A++	A++	A++	A++
		Low-temperature	A++	A++	A++	A++
J	Water heating energy efficiency class		A+	A+	A+	A+
K	Rated heat output (Average)	Medium-temperature	5.0	8.0	12.0	16.0
		Low-temperature	5.0	8.0	13.0	16.0
L	Annual energy consumption for space heating (Average)	Medium-temperature	3224	5113	7051	9379
		Low-temperature	2548	3719	5725	7385
M	Annual electricity consumption for water heating (Average)		692	729	1393	1245
N	Seasonal space heating energy efficiency (Average)	Medium-temperature	125	126	138	138
		Low-temperature	175	175	185	176
O	Water heating energy efficiency (Average)		148	141	120	135
P	L _{WA} (sound power level, indoor)		dB	-	-	-
Q	Work only during off-peak hours		(Yes/No)	No		
R	Specific precautions ¹⁾		-	-	-	-
S	Rated heat output (Colder)	Medium-temperature	4.0	6.5	11.0	14.5
		Low-temperature	4.5	6.5	12.0	14.5
T	Rated heat output (Warmer)	Medium-temperature	5.0	7.5	12.0	15.5
		Low-temperature	5.0	7.5	13.0	15.5
U	Annual energy consumption for space heating (Colder)	Medium-temperature	3992	6333	10310	14017
		Low-temperature	3081	4426	8082	10390
V	Annual energy consumption for space heating (Warmer)	Medium-temperature	1801	2658	4164	5449
		Low-temperature	1102	1664	2731	3378
W	Annual electricity consumption for water heating (Colder)		kWh	-	-	-
X	Annual electricity consumption for water heating (Warmer)		kWh	-	-	-
Y	Seasonal space heating energy efficiency (Colder)	Medium-temperature	96	98	102	99
		Low-temperature	141	142	143	136
Z	Seasonal space heating energy efficiency (Warmer)	Medium-temperature	145	148	151	149
		Low-temperature	239	238	251	242
AA	Water heating energy efficiency (Colder)		%	-	-	-
AB	Water heating energy efficiency (Warmer)		%	-	-	-
AC	L _{WA} (sound power level, outdoor)		dB	61	63	64

AD ¹⁾ Precautions as described in the installation/user manual must be taken when assembling, installing and maintaining this product

PRODUCT FICHE (ENERGY LABELLING OF PACKAGE OF COMBINATION HEATER)

Supplier's name or trademark		-	Samsung Electronics Co, Ltd.			
B	Supplier's model identifier	-	AE050RYDEG EU / MIM-ED03xN / Joule 200L H.G Cyclone	AE080RYDEG EU / MIM-ED03xN / Joule 200L H.G Cyclone	AE120RYDEG EU / MIM-ED03xN / Joule 200L H.G Cyclone	AE160RYDEG EU / MIM-ED03xN / Joule 200L H.G Cyclone
AE	Preferential heater		-	-	-	-
AF	Seasonal space heating energy efficiency class (Average)		A++	A++	A++	A++
N	Seasonal space heating energy efficiency (Average)		127	128	140	140
Y	Seasonal space heating energy efficiency (Colder)		98	100	104	101
Z	Seasonal space heating energy efficiency (Warmer)		147	150	153	151
AG	Weight factor (Preferential and Supplementary heater)		0	0	0	0
AH	Value of III [(294/(11 x Prated)]		5.3	3.3	2.2	1.7
AI	Value of IV [(115/(11 x Prated)]		2.1	1.3	0.8	0.7
AJ	Difference between the seasonal space heating energy efficiencies under average and colder climate conditions		29	28	36	39
AK	Difference between the seasonal space heating energy efficiencies under warmer and average climate conditions		20	22	13	11
AL	Water heating		-	-	-	-
AM	Seasonal water heating energy efficiency class (Average)		A+	A+	A+	A+
AN	Water heating energy efficiency of the combination heater (Average)		128	141	120	135
AO	Value of [(220 x Qref)/(Qnonsof)]		-	-	-	-
AP	Value of [(Qaux x 2,5)/(220 x Qref)]		-	-	-	-
AQ	Declared load profile (Average)		L	L	XL	XL
AO	Temperature controls		-	-	-	-
A	Supplier's name or trademark		-	Samsung Electronics Co, Ltd.		
B	Supplier's model identifier		-	MIM-ED03N		
AS	the class of the temperature control		-	Class II		
AT	the contribution of the temperature control		%	2		

Applicable date: 22/01/2021
Revision: 2.0
Document Control No: COM0055

JOULE IE

Unit 407 NW Business Park,
Cappagh Road, Ballycoolin,
Blanchardstown, Dublin

tel +353 (1) 623 7080
fax +353 (1) 626 9337
mail info@joule.ie
web www.joule.ie

JOULE UK

Unit 1 & Unit 3,
Leftfield Park, Park Road, West Yorkshire,
WF8 4PS, United Kingdom

tel +44 (0) 330 808 8488
fax +44 (0) 1513 568 336
mail info@jouleuk.co.uk
web www.jouleuk.co.uk

JOULE PL

Strzegomska 55D,
53-611 Wrocław, Polska

tel +48 (0) 128811171
fax +48 (0) 814709046
mail biuro@joule-pl.pl
web www.joule-pl.pl