portway

S T O V E S

Arundel Wood

Model No. PCWSB3

Installation and Operating Instructions

Eco-Design 2022 Compliant Wood Stove

**Read these Instructions and
use only the recommended wood fuels**

**Leave this manual with the householder following
installation**

To find a qualified installer, fuel supplier or chimney sweep please contact :-

UK - The Solid Fuel Association
7 Swanwick Court
Alfreton
Derbyshire
DE55 7AS
Tel : (0845) 601 4406
www.solidfuel.co.uk

R.O.I. - Irish Nationwide Fireplace Organisation
162 Capel Street
Dublin
Tel (01) 801 5959
www.fireplace.ie

This Portway Arundel Wood Stove may be used in smoke control areas when operated strictly in accordance with these instructions and with Soliftec Smoke Advice Sheet No. 1 (www.soliftec.com/smokeadvice.htm) when burning :

UK : Untreated wood logs

ROI : Wood logs (Control of Atmospheric Pollution Regulations, 1970)

Information Requirements for Commission Regulation (EU) 2015/1186

Model Identifier	PCWBS3
Indirect Heating Functionality	No
Direct Heat Output	5.0kW
Indirect Heat Output	Not Applicable
Fuel	Wood logs with moisture content <25%
Nominal Heat Output (Measured)	5.0kW
Minimum Heat Output (Indicative)	3.0kW
Seasonal / Useful Efficiency at Nominal Heat Output	83.1%
Useful Efficiency at Minimum Heat Output (Indicative)	50.0%
Energy Efficiency Index	110%
Auxilliary Electricity Consumption at Nominal Heat Output	Not applicable
Auxilliary Power Consumption at Minimum Output	Not applicable
Auxilliary Power Consumption at Standby Mode	Not applicable
Permanent Pilot Flame Requirement	Not applicable
Type of Heat Output / Room Temperature Control	Single stage heat output, no room temperature control
Harmonised standard applied	BS EN 13240:2001+A2:2004
Notified Body	KIWA 0558
Contact Details	BFM Europe Ltd. Gordon Banks Drive Trentham Lakes North Stoke-on-Trent ST4 4TJ Tel : 01782 339000

Contents	Description	Page Number
Section 1	Stove Information	3
Section 2	Stove Installation Requirements & Smoke Control Appliance Exemption.	4-7
Section 3	Stove Flue Connection to Chimney	8-9
Section 4	Suitable Wood Fuel	10
Section 5	Operation of the Portway Arundel Wood Stove	11
Section 6.1	Lighting the Stove - Installer Instruction	12
Section 6.2	Break in Fires - User Instruction	12
Section 6.3	Lighting the Stove - User Instruction	12
Section 6.4	Re-fuelling the Fire - User Instruction	13
Section 6.5	Maintenance	13
Section 7	Troubleshooting	14
Section 8	Removal & Re-Fitting the Stove Throat Plate	15
Section 9	Removal & Re-Fitting the Stove Smoke Stop	16
Section 10	Spare Parts	17

Section 1 - Stove Information

- 1.1 This Portway Arundel Wood Stove meets the safety and performance requirements of European Standard EN 13240 for intermittent burning solid fuel roomheaters for installation in a dedicated chimney when operated in accordance with these instructions. Independently tested by KIWA, Cheltenham, UK.
- 1.2 Stove Dimensions - see figure 1 below.

Fig. 1

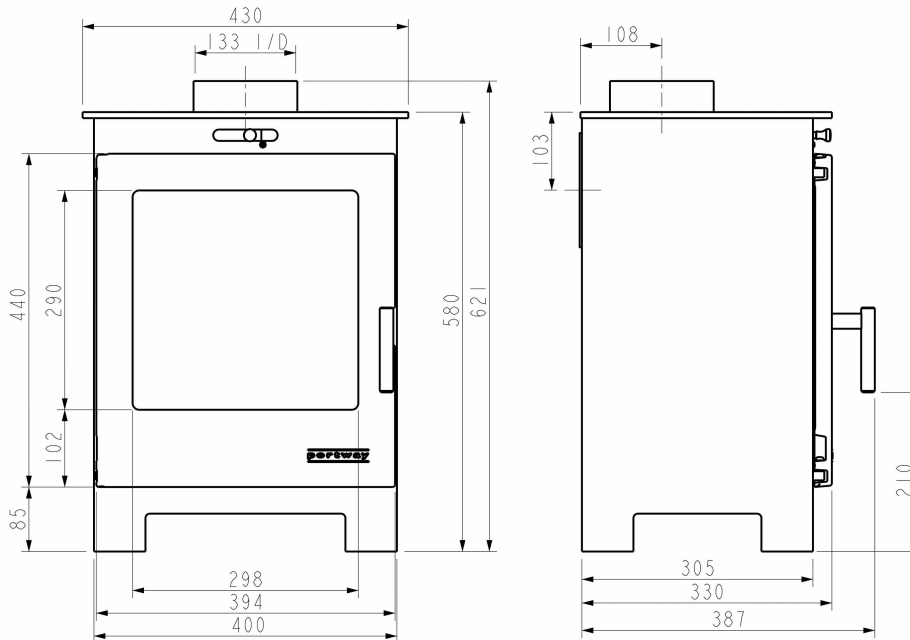

The stove is supplied with the following loose items :-

1 off ashpan, 1 off ashpan handle tool & 1 off stove glove.

Section 2 - Stove Performance Data

Fuel	Wood (Beech)
Test standard	EN 13240
Re-fuelling Interval	0.83hrs
Settings	0% primary, 50% secondary
Flue draught (Pa) (ins WG)	12 (0.05)
Efficiency	83.1%
Recommended output (kW)	5.0
Mean flue gas temperature (°C)	252
Minimum air entry requirement	2700mm ²
Minimum clearance to combustible surfaces	550mm Rear, 400mm Side.
Emissions if O₂ = 13%	
CO %	0.10
Flue gas mass flow (g/s)	3.7
Mean CnHm (Nmg/m ³)	92
Mean NOx (Nmg/m ³)	84
DIN Plus Dust (Nmg/m ³)	8

Section 2 - Stove Installation Requirements

- 2.1 **WARNING** - Installing a stove is a controlled service, the law requires that the installation is completed by a qualified installer or that the building inspector is informed. Check with your local authority.
- 2.2 **ASBESTOS** - This Portway stove does not contain asbestos, but asbestos material may be encountered during installation of the stove. If in doubt contact a suitably qualified professional to deal with Asbestos or material suspected to be asbestos.
- 2.3 **WEIGHT** - Your stove is heavy 62kg Net (74kg packed) - take care when moving it and ensure that the fireplace to which you are attempting to install it can take the weight - consider the use of a load distribution plate.
- 2.4 **FIREGUARD** - This stove becomes extremely hot in use, therefore a fireguard should be used if children, the elderly or infirm are present.
- 2.5 **FIREPLACE** - Stoves become extremely hot within use, therefore the fireplace to which the stove is installed must be made from durable fireproof materials. Thin stone slabs (less than 50mm) risk cracking unless cut into sections to allow for expansion and backed by heat resistant concrete. Even beyond the safety clearances stated items subjected to radiant heat from the stove can still become extremely hot, therefore please take care when siting items such as fuel, paper etc.
- 2.6 **AIR SUPPLY** - Your stove needs air to breathe and therefore perform correctly. There must be a permanent fresh air supply into the space to which it is installed equal to 550mm² for each kW of output. This can often be provided by air leaking around door frames etc. It is commonly accepted that this level of adventitious ventilation alone may suffice for stoves of output less than 5kW but in the case of any doubt, fit a purpose made air vent. If an extractor fan is fitted in the room, any interconnecting room or room in the vicinity can detrimentally affect the performance of the stove so please check stove performance with these extraction fans in operation. Where there are additional combustion appliances within the property please ensure that the relevant requirements of Approved Document J of the Building Regulations are complied with.
When air inlet grills are positioned to provide combustion air they must not be liable to blockage. Regular checks should be made to ensure that any air inlet grill is not obstructed.
- 2.7 **REGULATIONS & HEARTH REQUIREMENTS:** All local regulations including those referring to National and European standards need to be complied with when installing this stove. Refer to the current version of BS 8303, Code of Practice for installation of domestic heating and cooking appliances burning mineral fuel. Refer to the current version of BE EN 15287-1, Design, Installation and Commissioning of Chimneys.
The hearth should extend a minimum at least 600mm in front of the stove (Portway recommend 400mm) and 150mm to each side. A minimum of 50mm clearance to non-combustible materials is required at each side of the stove for access for servicing and maintenance. There must be no combustible material positioned within 1000mm of the front of the stove.

- 2.8 **CHIMNEY** - The chimney must conform to the following requirements :-
- 2.8.1 Generate a draught when in use of minimum 12 Pa (0.05 ins WG).
 - 2.8.2 Have a minimum internal cross section equivalent to not less than 125mm diameter or rectangular / square flues having the same cross sectional area and a minimum dimension not less than 100mm for straight flues or 125mm for flues with bends or offsets.
 - 2.8.3 Be capable of withstanding the flue gas temperatures generated by the stove.
 - 2.8.4 Terminating at least 1 metre above the ridge.
 - 2.8.5 Be free from any cracks or sources of leakage and be sealed throughout its entire length to prevent leakage of products of combustion into the property.
 - 2.8.6 Have no bends greater than 45 degrees.
 - 2.8.7 Have no obstructions and having been swept throughout its entire length.
 - 2.8.8 Being connected only to this Portway stove.
 - 2.8.9 Conforming to local building regulations and rules in force.
 - 2.8.10 Being adequately insulated.
 - 2.8.11 Where the flue passes through timber or thatch or vulnerable materials specialist advice must be sought.
 - 2.8.12 THIS APPLIANCE MUST NOT BE INSTALLED ON A SHARED FLUE SYSTEM.

2.9 **APPLIANCE EXEMPTION UNDER SECTION 21 OF THE CLEAN AIR ACT 1993 AND SMOKE CONTROL AREAS**

- 2.9.1 The Portway Arundel Wood free-standing stove, model number PCWSB3 has been exempted under the Clean Air Act 1993 for use in smoke control areas when burning wood logs when it is fitted with the smoke control stop (part number F-176950)
- 2.9.2 Under the Clean Air Act local authorities may declare the whole or part of the district of the authority to be a smoke control area. It is an offence to emit smoke from a chimney of a building, from a furnace or from any fixed boiler if located in a designated smoke control area. It is also an offence to acquire an "unauthorised fuel" for use within a smoke control area unless it is used in an "exempt" appliance ("exempted" from the controls which generally apply in a smoke control area).
- 2.9.3 In England appliances are exempted by publication on a list by the Secretary of State in accordance with changes made to sections 20 and 21 of the Clean Air Act 1993 by section 15 of the Deregulation Act 2015. Similarly, in Scotland appliances are exempted by publication on a list by Scottish Ministers under section 50 of the Regulatory Reform (Scotland) Act 2014. In Northern Ireland appliances are exempted by publication on a list by the Department of Agriculture, Environment and Rural Affairs under Section 16 of the Environmental Better regulation Act (Northern Ireland) 2016. In Wales appliances are exempted by regulations made by Welsh Ministers.
Further information on the requirements of the Clean Air Act can be found here : <http://smokecontrol.defra.gov.uk>
Your local authority is responsible for implementing the Clean Air Act 1993 including designation and supervision of smoke control areas and you can contact them for details of Clean Air Act requirements.

2.9 **APPLIANCE EXEMPTION UNDER SECTION 21 OF THE CLEAN AIR ACT 1993 AND SMOKE CONTROL AREAS (CONTINUED).**

2.9.4 **Refuelling on to a low fire bed**

If there is insufficient burning material in the fire bed to light a new fuel charge, excessive smoke emission can occur. Refuelling must be carried out onto a sufficient quantity of glowing embers and ash that the new fuel charge will ignite. If the fire bed is too low or cool, suitable kindling must be used to re-light fires.

2.9.5 **Fuel overloading**

The maximum amount of fuel specified in this manual must not be exceeded, overloading can cause excessive smoke.

2.9.6 **Operation with door left open**

Operation with the door left open can cause excessive smoke. The appliance must not be operated with the door left open except as directed in the instructions.

2.9.7 **Dampers left open**

Operation with the air controls or dampers can cause excessive smoke. The appliance must not be operated with the air controls or dampers left open except as directed in the instructions.

2.10 **REQUIREMENTS TO FIT A CARBON MONOXIDE (CO) ALARM**

2.10.1 When this stove is installed, Building Regulations require that whenever a new or replacement fixed solid fuel or wood/biomass appliance is installed in a dwelling a carbon monoxide alarm must be fitted in the same room as the appliance. Further guidance on the installation of the Carbon Monoxide alarm is available in the latest version of BS EN 50292 and from the alarm manufacturers instructions.

2.10.2 IMPORTANT NOTE : The installation a Carbon Monoxide (CO) alarm is not a substitute for installing the appliance correctly, regular servicing and maintenance of the chimney / flue or the stove itself. Please ensure that regular servicing in accordance with section 7.6 of this manual is completed.

2.10.3 WARNING NOTE : Properly installed, operated and maintained this stove will not emit fumes into the dwelling. Occasional fumes from de-ashing and re-fuelling may occur. However, persistent fume emission is potentially dangerous and must not be tolerated. If fume emission does persist the following action must be taken:-
Open windows and door to ventilate the room and then leave the premises.
Let the fire go out.
Check for chimney blockage and clean if required.
Do not attempt to re-light the fire until the cause of fume emission has been identified and corrected. If necessary seek expert advice.
The most common cause of fume emission is flueway or chimney blockage. For your own safety these must be kept clear at all time.

Section 3 - Stove Flue Connection to the Chimney

3.1 The flue can be connected to the stove via either the top or the rear outlet. The stove can then be sealed to the chimney using a short length of uninsulated flue pipe as shown below and overpage in figures 2, 3 & 4.

3.1.1 Top flue outlet into existing chimney - figure 2

Fig. 2

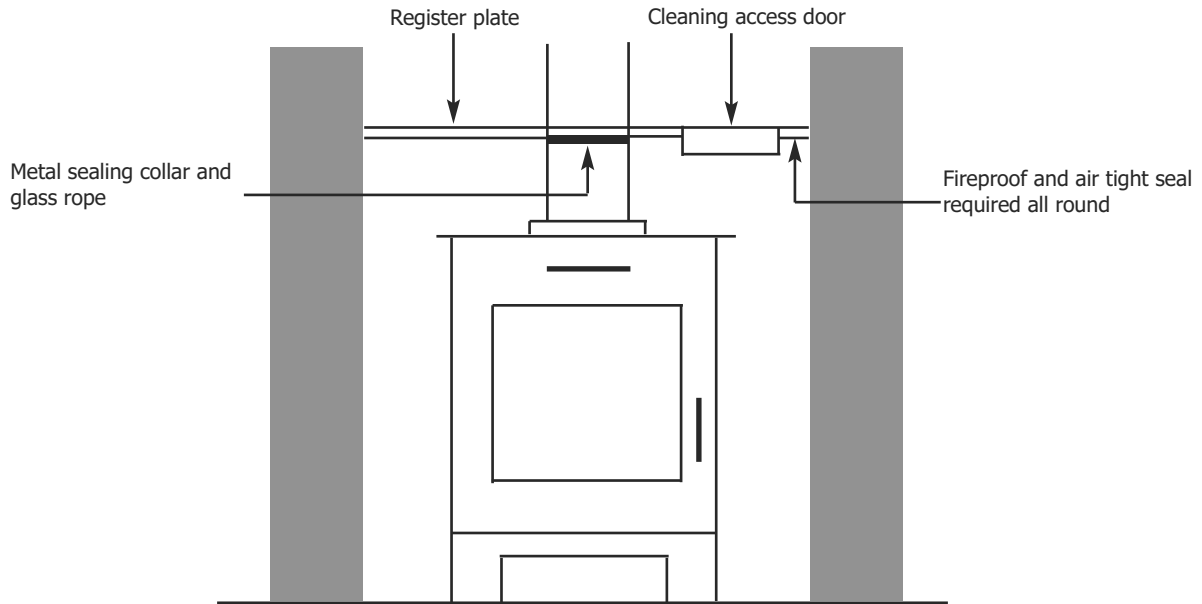

3.1.2 Top flue outlet sleeved through wall into external insulated flue - figure 3

Fig. 3

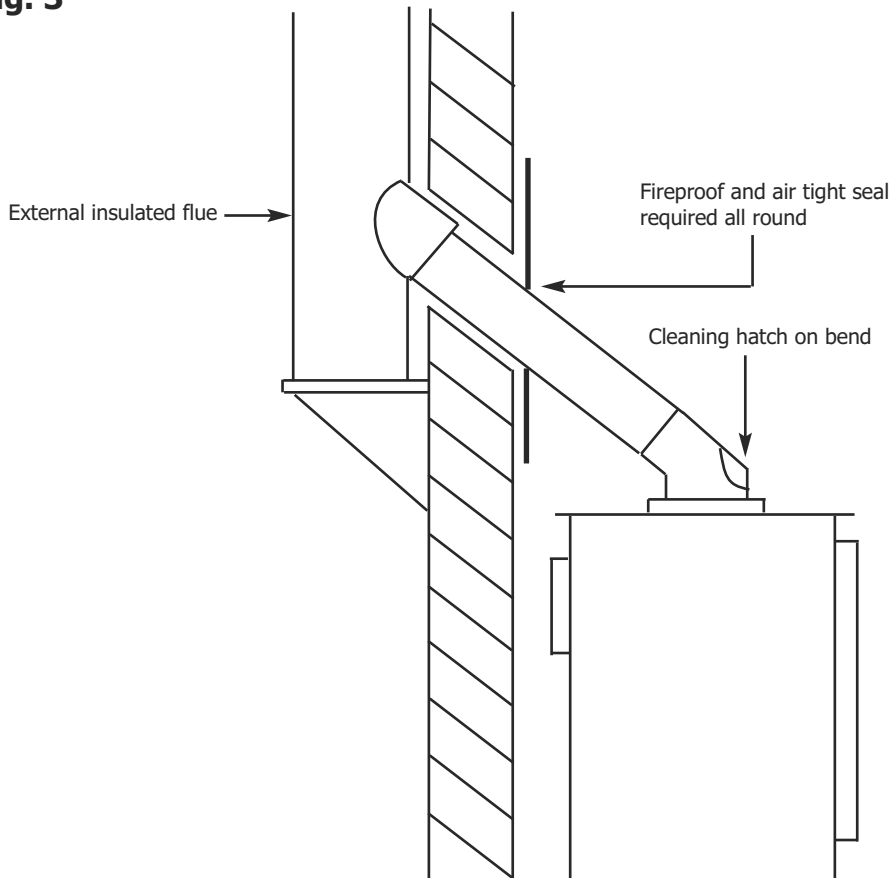

3.1.3 Rear flue outlet into chimney with sealing collar - figure 4

Fig. 4

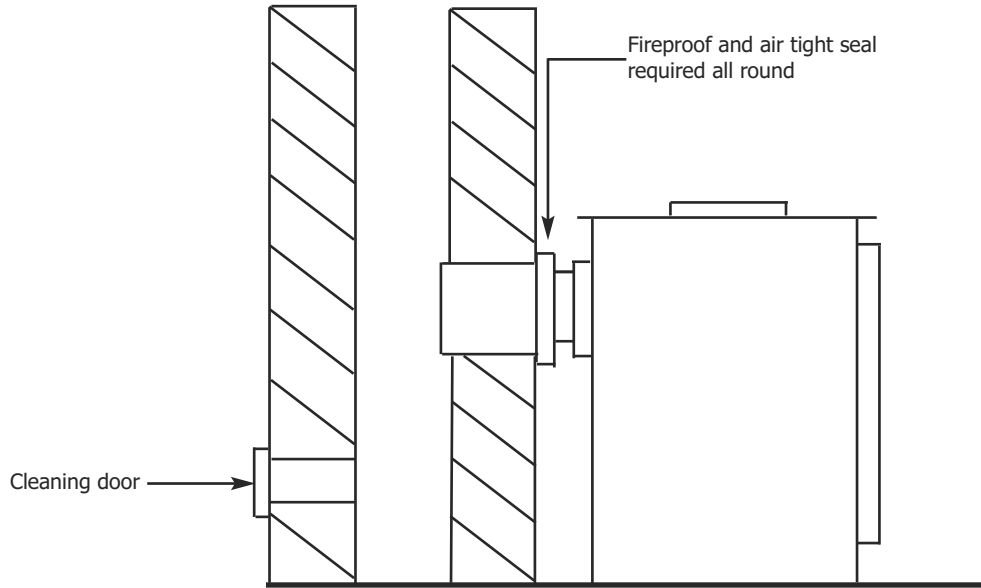

3.1.4 Rear outlet by "tee" piece with cleaning door - figure 5

Fig. 5

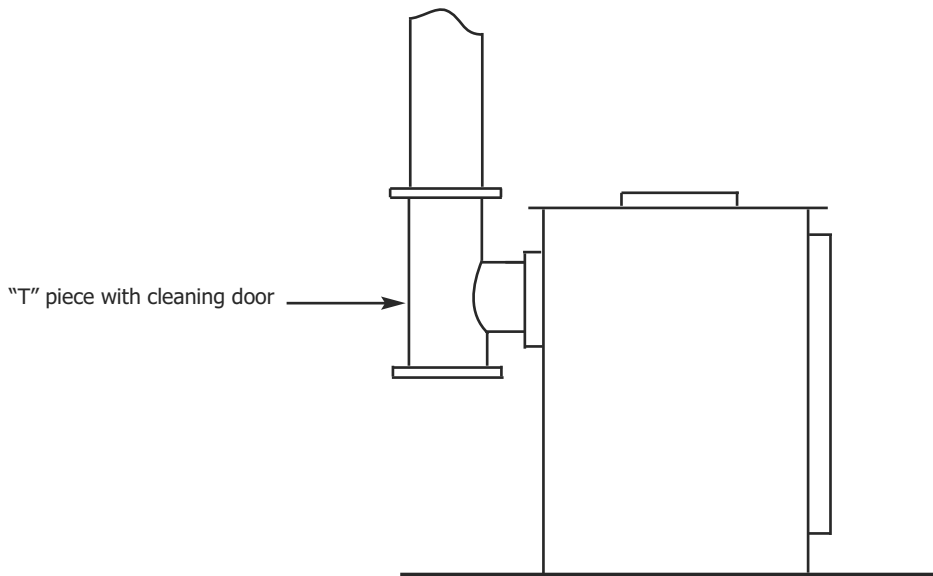

3.1.5 **IMPORTANT INFORMATION** - whichever method is used it is imperative that the route from the stove to the chimney terminal is completely air-tight, even very small air gaps can adversely affect the flue draught. Seal all joins with fireproof cement and / or heatproof rope. The entire construction should be made of durable fireproof materials.

Section 4 - Suitable Wood fuel for the Portway Arundel Wood Stove - User instruction

- 4.1 SMOKE CONTROL - In certain areas special rules apply regarding the use of some fuels, please ensure that you check with your local authority. This Portway Arundel stove may be used in smoke control areas when operated strictly in accordance with these instructions and with Soliftec Smoke Advice sheet No. 1, see front cover of this manual for further details.
- 4.2 WOOD TYPES - All types of wood are suitable providing they are well seasoned, untreated and have a moisture level of between 12% & 20%. For softwoods they will need to have been left in storage for 9 months in order for the moisture to be evaporated. For hardwoods this could take in excess of 18 months for the wood to season. If you are unsure of the moisture content of your logs it is recommended that you purchase a suitable moisture meter which will allow you to measure the moisture content of the wood you are planning to use.
- 4.3 WOOD SIZE - It is recommended that logs should be no greater than 5" / 125mm in diameter and a maximum of 250mm in length. The logs must be dry with a moisture content no greater than 20%.
- 4.4 WET TIMBER WARNING - Wet timber and logs must not be used as this will create excess tar deposits in the chimney and the stove and could considerably increase the possibility of a chimney fire. Wet timber and wood also increases emissions, creates more smoke and will reduce the lifespan of the stove.
- 4.5 JOINERY WASTE - Burning joinery waste is acceptable, providing the wood is untreated and dry. Joinery waste generally is softwood and hence will not burn as cleanly or for as long as hardwood logs. In addition constant burning of such wood will increase tar deposits in the flue and require more regular sweeping than if burning hard wood.

IMPORTANT NOTE : DO NOT BURN ANY FORM OF HOUSEHOLD WASTE WITH THIS STOVE AND NEVER USE ANY FORM OF LIQUID FUEL ON THE STOVE.

Section 5 - Operation of the Portway Arundel Wood Stove - User Instruction

- 5.1 The air control on your stove is as shown below in figure 6. The stove is also supplied with a glove and an ashpan handle to be used as described in this section.

Fig. 6

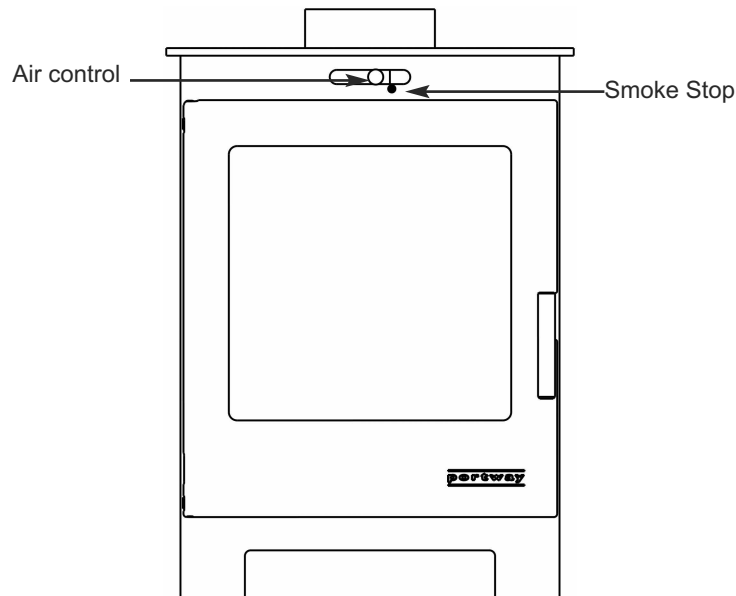

- 5.1.1 **Air control** - This is located above the stove door in the centre. The air control provides air for combustion and an air wash facility to keep the stove glass clean.
- 5.1.2 **Hand glove** - a glove is provided with the stove to adjust the air control, and open / close the door when the stove is hot. Please note all parts of the stove will become hot in use and care needs to be taken to avoid injury through burning.
- 5.1.3 **Ashpan & handle** - a ashpan and handle is supplied for use with the stove, please use this in conjunction with the glove and be aware that ash and embers in the ashpan will be extremely hot. Take care when discarding hot embers.
- 5.1.4 **Smoke Stop** - To make sure your stove always receives enough air to burn away the smoke produced when burning wood, a smoke stop is fitted to prevent the secondary air control from being fully closed. The smoke stop must always be in place when burning wood in smoke control areas of the United Kingdom.

Section 6.1 - Lighting the stove - Installer instruction

- 6.1 Prior to first lighting the stove ensure that the following is complete :-
 - 6.1.1 Installation of the stove and relevant building work is completed.
 - 6.1.2 The chimney is suitable, sound and free from obstruction.
 - 6.1.3 Adequate ventilation and provision for combustion air has been made.
 - 6.1.4 The installation is compliant with building regulations and local authority regulations as applicable.
 - 6.1.5 The chimney pull is a minimum of 12 Pa
 - 6.1.6 The fuels that are planning to be burnt comply with those listed as suitable in section 4 of this manual.

Section 6.2 - Break-in fires - User instruction

- 6.2.1 When the stove is new, for the first 20 hours burning only use gentle small controlled wood fires during which the first three fires must be small kindling wood fires only. This is required to correctly adhere the paintwork on the stove. After the first three fires gently increase the size of the fuel and duration of the burn time. **Failure to adhere to this instruction will result in likely damage to the paintwork on the stove. In addition, during the "break in fires" do not touch the paintwork on the stove as during this period the paintwork will be relatively soft and will mark easily.**

Section 6.3 - Lighting the stove - User instruction

- 6.3 When first lighting the stove comply with the following :-
 - 6.3.1 Ensure that the ash bucket is in place
 - 6.3.2 Ensure that the air control is in the fully open position (to the left hand side when viewed from the front).
 - 6.3.3 Construct a pile of kindling in the centre of the grate using approximately 1kg of kindling wood.
 - 6.3.4 Use two chemical firelighter in the base of the kindling and light with an appropriate ignition source. Leave the door partially open but do not leave the area of the stove.
 - 6.3.5 As soon as the fire is well established in the kindling, shut the door of the stove.
 - 6.3.6 After 5 minutes or as soon as the kindling is well lit, add a further 3 small pieces of wood of approximate weight 0.5kg.
 - 6.3.7 Once these logs are lit, after a further 5 minutes add a further 2 or 3 logs weighing approximately 1.2kg in total.
 - 6.3.8 Once these logs are lit, reduce the settings on the air control to a suitable level to suit your requirements.
 - 6.3.9 Re-fuel as per section 6.5 as and when required.
 - 6.3.10 **DO NOT OPERATE THE STOVE WITH THE DOOR PERMANENTLY OPEN.**
 - 6.3.11 This stove is not suitable for connection to a central heating system.
 - 6.3.12 **THIS STOVE MUST NOT BE USED AS AN INCINERATOR AND ONLY USE RECOMMENDED FUELS.**
 - 6.3.13 **IF BURNING WOOD IN SMOKE CONTROL AREAS PLEASE READ AND COMPLY WITH THE REQUIREMENTS OF SECTION 2.9**

Section 6.4 - Re-fuelling the fire - User instruction

- 6.4 When refuelling the stove, follow the procedure as detailed below :-
 - 6.4.1 Open the air control to the fully open position.
 - 6.4.2 Add up to 1.2kg of wood.
 - 6.4.3 After approximately 2 minutes or when the flames from the fresh fuel are fully established, close the air control to the desired position.
 - 6.4.4 At high power output your stove will require re-fuelling approximately every hour.
 - 6.4.5 Do not leave the stove until the newly added fuel is well established.
 - 6.4.6 Always refuel onto hot embers and riddle at each refuel.
 - 6.4.7 If the fire has died out at the point of refuelling use kindling and fire-lighters to re-establish the fire.
 - 6.4.8 **DO NOT OVERLOAD THE STOVE WITH FUEL.**
 - 6.4.9 Reduced burn rates can be achieved via use of the air control.
 - 6.4.10 This stove is suitable for intermittent burning and should not be used constantly for extended periods. Not suitable for overnight burning.
 - 6.4.11 During certain atmospheric conditions it may be difficult to achieve the required flue draught. If such conditions occur it may require a specialist cowl on the chimney to achieve the correct flue draught to ensure correct operation of the stove. In such circumstances do not use the stove and obtain expert advice.
 - 6.4.12 In the event of a chimney fire, close the air control on the stove, evacuate the building and call the fire brigade.

Section 6.5 - Maintenance - If in doubt contact a competent person

- 6.5 Regular cleaning and maintenance of the stove is essential for safety and efficiency. Portway recommend a suitably qualified (HETAS) registered engineer is used for servicing purposes. Ensure the following steps are completed regularly :-
 - 6.5.1 The ashbucket should be emptied after every use as required.
 - 6.5.2 When the stove is cold, clean out any build of ash or unburnt fuel from the grate, around the ash bucket and in any nooks or crannies of the stove. Complete monthly as a minimum, including on top of the stove throat plate, see section 8.
 - 6.5.3 The flue, flue pipe and chimney will require regular sweeping to minimise the build up of soot and tar, annually as a minimum. The stove should of been installed with suitable access doors in the flueway to achieve this. However in the event that suitable access doors have not been installed access to the flue can be achieved by removal of the throat plate in the stove itself, see section 8.
 - 6.5.4 If the stove door glass is stained, it may be that the air control may need to be opened up during use, this is dependent upon many factors such as flue pull etc. In the event of excessive staining use a ceramic glass cleaner to remove the marks when the stove is completely cool.
 - 6.5.5 Note that the internal boards of the stove will craze with normal use, this is not a fault with the boards. Cracks will not adversely affect the stove's performance providing the boards remain in position. If pieces break from the boards then replace the boards as necessary. You can significantly increase the life of the boards by burning the correct fuels in the stove as detailed in section 4.

Section 7 - Troubleshooting

7.1 In the unlikely event of experiencing problems with your stove, please consult the following :-

- 7.1.1 **Smoke from the chimney** - a little smoke will be emitted from the chimney when the fire is cold. Ensure the correct, dry wood to prevent smoke emissions.
- 7.1.2 **Poor heat output** - this Portway Arundel Wood stove will generally heat a room of 12m³ room volume per kW of heat output, so if operating at 5kW output it could heat a room of 12m³ x 5 = 60m³ or 5 metres square. The actual size depends upon factors such as insulation and air change within the room. To attempt to use too smaller stove to heat too larger room will result in overheating the stove and potentially damaging it.
- 7.1.3 **Lack of controllability** - some fuels may burn excessively until the gases in them have been used up, you can reduce this effect by using the air control on the stove.
- 7.1.4 **Difficulty burning for extended periods** - If the fire goes out with plenty of fuel in the stove, try leaving the air controls open a little more. Check the door seal is sound and that there are no gaps or cracks in the flue or flue joints.
- 7.1.5 **Overfiring** - If the stove is left with the air control in the fully open position for too long this will result in overfiring, excessive chimney temperatures and risk of component failure and chimney fires. Use a stove thermometer, available from your Portway stockist can help to obtain a satisfactory burn temperature.
- 7.1.6 **Smoke coming into the room** - Product of combustion (fumes) are poisonous and hence smoke emission must never be tolerated. If smoke comes back into the room when the stove is lit the cause must be fully investigated to ascertain the problem and rectified before using the stove. Check for build up of ash on the throat plate, the condition of the door seals, the condition of the seal between flue and chimney and any air ventilation into the room is not blocked. If the symptoms persist, consult a suitably qualified person, such as a HETAS registered engineer to further investigate and resolve the problem.

Section 8 - Removal & re-fitting the stove throat plate

If in doubt contact a competent person

- 8.1 Ensure that the stove is cool.
- 8.2 Open the stove door.
- 8.3 As shown in figure 7 below remove the throat plate from the stove, this is completed by sliding the throat plate forwards slightly until it is clear of the rear fibre board (step 1). Then tilt downwards and backwards slightly to clear the top retaining bracket (step 2). Finally rotate downwards and remove from the door of the stove (step 3). Clean off any fly ash etc. If using throat plate removal as a form of access to the chimney please ensure any debris that comes from the chimney is fully removed from the stove before attempting to refit the throat plate.
- 8.4 Replace in reverse order.
- 8.5 Check the stove for correct performance and flue products clearance.

Fig. 7

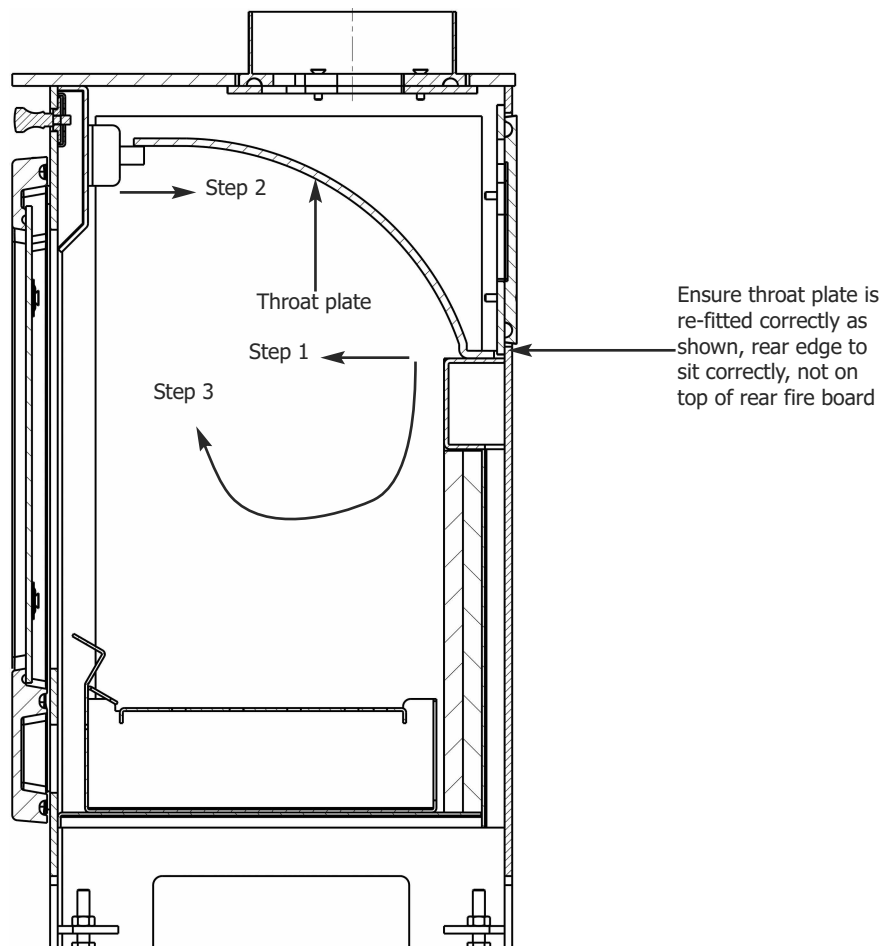

Section 9 - Removal & re-fitting the smoke stop

If in doubt contact a competent person

- 9.1 **WARNING :** The smoke stop is fitted to ensure that your stove receives enough air to burn away the smoke when burning wood. The smoke stop is fitted to prevent the secondary air control being fully closed. If, and only if smoke is not a concern you may unscrew and remove the smoke stop that was fitted during the manufacture of your Portway Arundel Wood stove. Controllability and burn times may be improved, but more smoke may also be emitted. The smoke stops must always remain in place when burning wood in smoke control area's of the United Kingdom. Failure to do so invalidates the DEFRA approval of the stove.
- 9.2 To remove the smoke stop, firstly ensure that the stove is cool.
- 9.3 Locate the smoke stop on the air control as shown below in figure 8.

Fig. 8

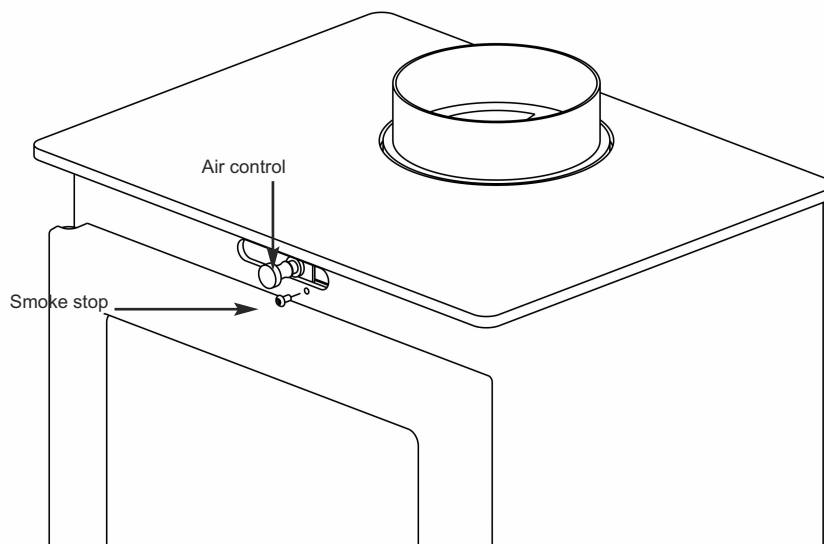

- 9.4 Remove the smoke stop by unscrewing in a anti-clockwise direction.
- 9.5 Keep the smoke stop in a safe place for future use.
- 9.6 Re-fit in reverse order if necessary.

Section 10 - Spare Parts

IMPORTANT : Only genuine Portway spare parts should be used with this stove and no unauthorised modifications to this stove are permitted.

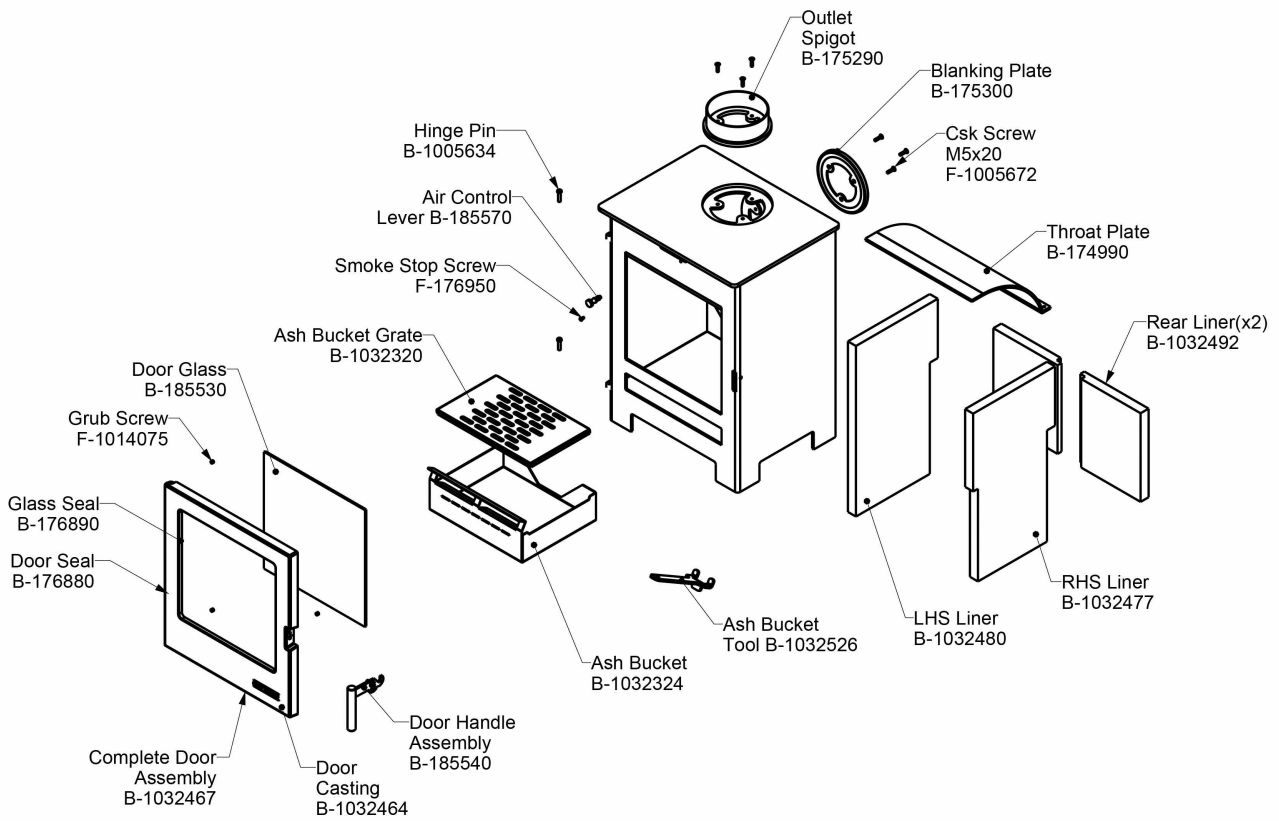

Due to our policy of continual improvement and development the exact accuracy of illustrations and descriptions contained in this book cannot be guaranteed.

**B-1032572
Issue 2
22nd November 2022**

portway
S T O V E S

BFM Europe Ltd.
Trentham Lakes
Stoke-on-Trent
Staffordshire
ST4 4TJ

www.bfm-europe.com

Spare Parts - www.bfm-partfinder.co.uk

Telephone - General Enquiries :
Telephone - Service :

(01782) 339000
(01782) 339008