

Firefox 5CB (Clean Burn)

DEFRA APPROVED FOR BURNING WOOD IN A SMOKE CONTROLLED AREA
CE APPROVED.



Clean burn cast iron wood burning stove
Installation & operating instructions. To be left with user.

This appliance must be installed by a competent person and must comply with all building regulations including those referring to local authority by-laws, National and European Codes of Practice . Unless the installer is qualified to approve the installation, then approval must be sought from your local building control officer. It is an offence under UK law not to comply with this advice. After installation the appliance should be ready for use and instruction as to use and control given.

FFXCB 01/10A

Health & Safety

- The Firefox 5 CB stove does not contain asbestos.
- Do not use in a shared flue.
- Do not use this appliance as an incinerator.
- Use only the recommended fuel – do not use liquid fuels.
- The surfaces, glass panel, and stove pipe reach very high temperatures. All persons in the vicinity of the stove must be warned of the potential dangers
- No combustible materials to be within 450mm from any surface of the stove, including the stove pipe.
- No soft furnishings to be within 900mm of stove surfaces or stove pipe.
- Fire cement contains caustic material, avoid contact with skin.
- Do not make any unauthorised modifications to this appliance.
- If replacement parts are required, use only parts recommended by manufacturer.

Fires can be dangerous - the Firefox 5 CB stove operates at very high temperatures. Always use a fire guard to BS6539 specification in the presence of children, the elderly or the infirm. Inform all persons the dangers of high temperatures during operation of appliance including the stove pipe and use the operating tools provided. The mitten provided is a tool.

Do not over fire - it is possible to fire the stove beyond its design capacity. This could damage the stove, so watch for signs of over-firing, if any part of the stove starts to glow red, the fire is in an over fire situation and the controls should be adjusted accordingly. Never leave the stove unattended for long periods without adjusting the controls to a safe setting. Careful air supply control should be exercised at all times.

Warning- Fume emissions - properly installed and operated, this appliance will not emit fumes. Occasionally fumes from de-ashing and refuelling may occur. Persistent fume emission must NOT be tolerated.

If fume emission does persist, then following immediate action should be taken-

1. Open doors and windows to ventilate the room.
2. Let the fire out, or eject and safely dispose of fuel from the appliance.
3. Check for flue chimney blockage, and clean if required.

Do not attempt to relight the fire until the cause has been identified. If necessary seek professional advice.

Do not fit an extractor fan in the same room as the appliance

Parts & Assembly

Stove Assembly

The stove legs will be found inside the stove, they will require fitting. The two front legs have optional positions either at front of ash lip or rearward inline with body panels. Two of the legs have holes for hearth fixing fit these in desired position.

Fitment of legs - lean stove backwards and prop under base panel, fit studs supplied in desired position for legs, locate legs, fit washers and nuts and tighten. Lean stove forwards and prop under base panel, fit rear legs using studs washers and nuts provided. **Note** - the Firefox 5 CB is heavy take care when handling.

Item	Description	Part No	Qty
1	Flue Collar	FFX008 CB	1
2	Stove Top Panel	FFX003 CB	1
3	Stove Back Panel	FFX034 CB	1
4	Heat Shield	FFX030 CB	1
5	Ceramic Chamber Lining	FFX 023 CB	1
6	Right Side Panel	FFX036 CB	1
7	Side Brick	FFX012 CB	1
8	Back Brick	FFX013 CB	1
9	Grate Riddling Rod & Knob	FFX015 CB	1
10	Ash Pan	FFX014 CB	1
11	Base Panel	FFX002 CB	1
12	Leg	FFX010 CB	4
13	Data Plate	FFX031 CB	1
14	Fret	FFX011 CB	1
15	Door Handle	FFX016 CB	2
16	Primary Air Slide Knob	FFX022 CB	1
17	Primary Air Slide	FFX020 CB	1
18	Door	FFX004 CB	1
19	Glass	FFX018 CB	1
20	Grate Support Plate	FFX 005 CB	1
21	Grate	FFX 006 CB	1
22	Left Side Panel	FFX036 CB	1
23	Side Brick	FFX012 CB	1
24	Front Panel	FFX035 CB	1
25	Secondary Air Duct	FFX 024 CB	1
26	Top Brick Assembly	FFX009 CB	1

Item	Description	Part No	Qty
27	Baffle Plate	FFX007 CB	1
Items Not Shown on Diagram			
28	Glass Panel Seal	FFX027 CB	1
29	Door Seal	FFX026 CB	1
30	Operating tool	FFX029 CB	1
31	Mitten	FFX1 CB	1
32	Door Catch	FFX017 CB	1
33	Door Glass Retaining Tabs	FFX019 CB	4
34	Hinge Pin	FFX028 CB	2
35	De-ashing Tool	FFX039 CB	1

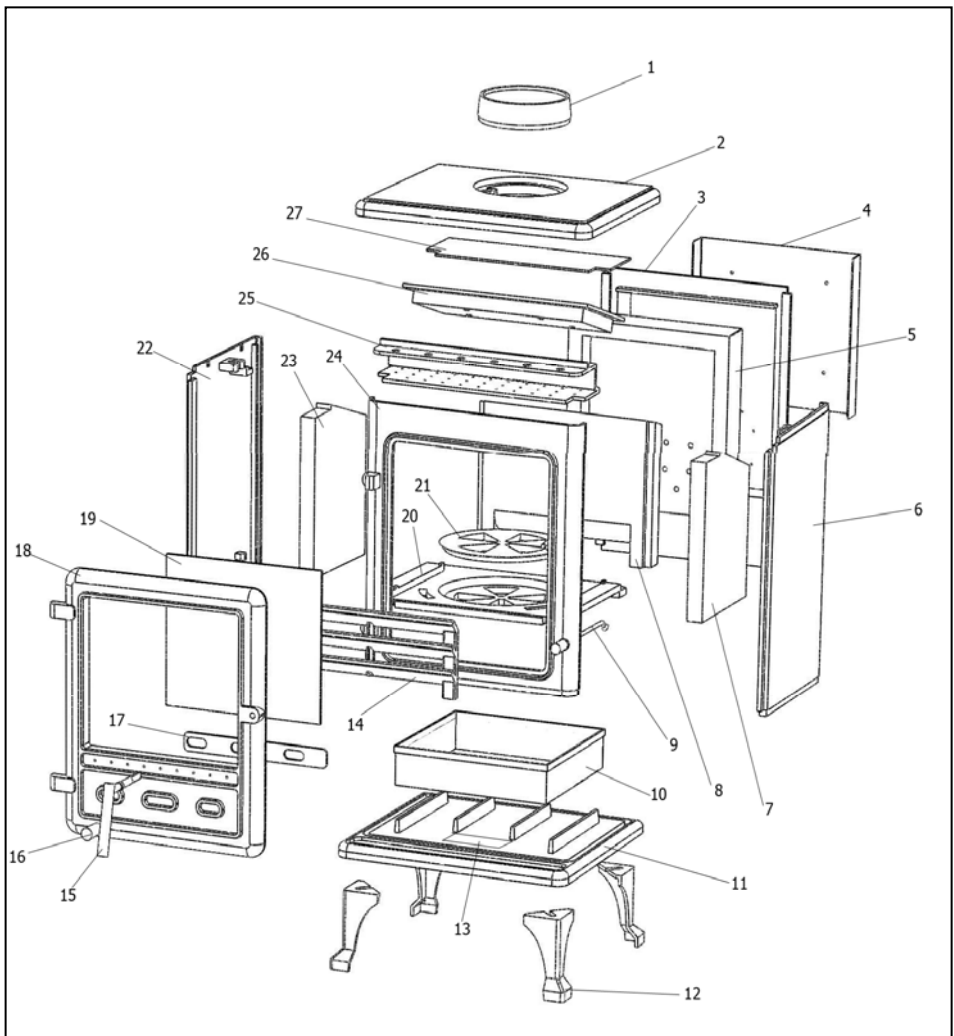

Installation

Check the chimney is in good condition, dry, free from cracks and obstructions. The diameter of the flue should not be less than 150mm and not more than 230mm. If any of these requirements are not met, the chimney should be lined by a suitable method.

The chimney height and the position of the chimney terminal should conform to Building Regulations.

A flue draught of minimum 12 Pascals water gauge is required for satisfactory appliance performance. The flue draught should be checked under fire at high output and if it exceeds the recommended maximum, a draught stabiliser must be fitted so that the rate of burning can be controlled, and to prevent over firing. If you have any doubts about the suitability of your chimney, consult your local dealer/stockist.

The chimney must be swept before connection to the stove and swept every six months thereafter. If there is an excessive build up of soot, then the chimney must be swept and the reason for build up investigated.

An existing fireplace opening can be bricked up or sealed with a register plate, 2.5mm steel sheet or concrete. A short length of flue pipe no smaller in diameter than the stove flue outlet or the manufacturer's stated flue size may then be used to connect the stove to the chimney. This flue pipe should be of cast iron, 316 grade stainless steel or vitreous enamelled, nominal thickness 1.2mm. Ensure that the pipe end is no closer than 76mm to the side or rear chimney walls.

Ideally, the old fireplace should be filled in so that there is a smooth streamlined entry into the flueway.

The length of any horizontal run of the flue pipe must not exceed the flue outlet diameter on the stove.

It is essential that all connections between the stove and chimney-flue are sealed and made airtight.

Both chimney and flue pipe must be accessible for cleaning and if ALL parts of the chimney cannot be reached through the stove, a soot door must be fitted to enable this to be done.

If a change in direction is required in the pipe work then it should be no less than 45 degrees. If a 90 degree bend is required then a swept elbow should be used, or 2 x 45 degree elbows. A clean out point at every change of direction is recommended.

Installation Continued

The stove can be recessed in a suitable sized fireplace but a permanent free air gap of at least 100mm must be left around the sides and top to obtain maximum heat output and for access to the rear of the stove. There should not be any combustible material within a distance of 450mm from any surface of the stove. Furniture and general soft furnishings should not be within 900mm of any stove surfaces including the stove pipe. In all instances the stove should be positioned on a non-combustible hearth. Allow an apron of at least 300mm at the front of the stove and 150mm on either side. The hearth on which the stove is to be placed should not be less than 125mm thick if the floor is made of combustible material, and care should be taken to level the stove and secure the hearth. If existing floors do not have adequate load bearing capacity then suitable modifications i.e. load bearing plates must be adopted.

When the stove is desired position mark hearth through holes in feet, remove stove drill and plug hearth for securing stove and levelling.

Upon completion of installation, the appliance should be checked under fire for soundness of joints and seals, and also that all smoke and fumes are taken from the appliance, up the chimney and emitted safely.

Care should be taken that all flues, hearths, and combustion air supplies are in accordance with the current Building Regulations, Local Authority Bye-Laws, British Standards and Codes of Practice. The Firefox 5 CB has no ventilation requirement but a fixed vent is advisable as this will enhance the pull of the chimney and reduce unwanted draughts. Care should be taken that these opening cannot become obstructed. Considerations and provisions must be made for any other appliances requiring ventilation. An extractor fan must not be used in the same location as the appliance. This appliance is not to be used with a shared chimney.

Operating Instructions

The appliance uses the down burn principle unlike conventional stoves where the flame path rises up to the baffle plate in the top of the stove, circulates around the baffle then out through the flue outlet. The down burn stove has a throat at the bottom rear of the fire box. Behind the back brick is a combustion chamber that has its own air supply, the flame passes up into the fire box then down into the throat, it then enters the combustion chamber where it is injected with pre-heated air. This causes a rise in temperature burning off smoke particles, creating cleaner emissions. After entering the combustion chamber the hot gasses circulate around the inner baffle and out round the flue outlet.

The secondary and tertiary air supplies create the clean burn function; these air supplies are not adjustable. The primary air supply controls the burn rate. There is a fixed primary air bleed on the door located above the primary air slide.

Operating Instructions

The appliance has been extensively tested and meets all the requirements necessary to burn wood in smoke controlled areas and is DEFRA approved. If the appliance is installed, operated and regularly serviced correctly it will offer many years of reliable service.

The primary air slide at the bottom of the door is the only variable control for the fire. It is marked (+) meaning more air, and (-) meaning less air. When the slide is in the maximum (+) direction, the stove will achieve its maximum heat output. When the slide is in its minimum (-) direction, this stove is in a high efficiency tick-over mode.

Note - When the stove is in high output mode, more fuel will be consumed. It is necessary to establish a good ash bed and generate heat to the combustion chamber and flue (chimney), before significant restriction of primary air.

Chimney type, atmospheric conditions and fuel quality will affect the efficiency of the stove so some practice will be required to get the stove running correctly in your particular environment.

Warning - Do not load with excessive amounts of fuel, the clean burn efficiency will be affected, and internal panels could be dislodged.

Lighting the stove

We recommend that you have two or three small fires before you operate your stove to its maximum heat output. This is to allow the paint to cure and castings to relax and consolidate. Location we recommend 'running in' procedure after long shutdowns to preserve life of stove. During this you may notice an unpleasant smell. It is not toxic, but for your comfort we would suggest that during this period you leave all doors and windows open.

Although screwed up paper can be used to light the fire in the stove, we recommend the use of firelighters. Place one firelighter at the back of grate in front of the flue throat and ignite. Place kindling wood on closed grate in front of the firelighter, then place one firelighter in front of kindling wood. Leave the stove door ajar for 10 minutes as the fire establishes. Close stove door and open primary air supply at bottom of door.

Note - Don't forget to close stove door after approximately 10 minutes. When kindling is well alight, place medium sized logs on grate and allow to ignite gradually then build up to maximum size logs. When the fire bed is established close down primary air slide to desired position.

This stove is designed to be operated with the door closed. Except for establishing a fire and refuelling it is unsafe to operate with the door open.

Operating Instructions

Notes on Wood Burning - Wood burns best on a bed of ash and it is therefore only necessary to remove surplus ash from the grate occasionally. Burn only dry, well seasoned wood, which should have been cut, split and stacked for at least 12 months, with free air movement around the sides of the stack to enable it to dry out. Burning wet or unseasoned wood will create tar deposits in the stove and chimney and will produce unsatisfactory heat output.

Re-Fuelling

The stove will stay hot for sometime after the volatiles in the wood have been consumed. When more fuel is added it will ignite quickly, and primary air settings need not be adjusted. If the stove has cooled down too much but red embers are still visible then the primary air will require opening fully to ignite the new fuel added. Wood burns best on a bed of ash, so it is not necessary to remove the ash completely. But removal of ash from the throat is advisable and can be just dragged forwards. When re-fuelling, the air control should be fully opened for approximately 1 minute or until ignition is well established, then close to the desired setting.

De-ashing

De-ashing is only required when excessive amounts of ash have built up. The grate has two positions, open or closed. The open position is for de-ashing only. To de-ash open grate with control knob, scrape ash through grate opening with tool provided.

IMPORTANT - MAKE SURE ANY ASH BLOCKING THE FLUE THROAT (BOTTOM REAR OF THE FLUE BOX) IS REMOVED.

Recommended Fuels

Seasoned wood- moisture content less than 20%.
Should any difficulties arise over fuel quality or suitability consult your local supplier or the solid fuel advisory service.

General Maintenance

Basic maintenance can be carried out by the appliance operator, i.e. removal of baffle plate, bricks, grate, and glass replacement, must be done when the appliance is cold. Any structural repairs, i.e. panel or stove pipe replacement must be carried out by a suitably qualified engineer.

Cleaning

It will be necessary to clean fly-ash off baffle plate in the top of the stove at least once a month. When in regular use and after long shut down periods. To gain access to baffle lift top brick and slide it side and backwards, remove right hand side brick. Now top brick can be manipulated out of the stove door. You can now gain access to the baffle plate. This can be removed, cleaned off and replaced. The top brick is manipulated back into position and side brick replaced. Make sure top brick has located all round.

General Maintenance

Stove Body

The stove is finished with a heat-resistant paint and this can be cleaned with a soft brush. Do not clean whilst the stove is hot; wait until it has cooled down. The finish can be renovated with a suitable brand of paint.

Glass Panels

Clean the glass panel when cool with a proprietary glass cleaner. Highly abrasive substances should be avoided as these can scratch the glass and make subsequent cleaning more difficult. Wet logs on heated glass, a badly aimed poker or heavy slamming of doors could crack the glass panels. The glass will not fracture from heat.

Chimney

Check your chimney each year before starting to use your stove for the winter. Birds may have nested in the chimney or the masonry may have cracked. Both chimney and flue pipe must be swept at least once a year.

Grate Removal

To remove the centre grate, un-screw control knob from riddling rod, rotate grate anti-clockwise until rod passes out of guide hole. Now, manipulate grate out of stove door opening. Note the position of the hook on the end of the riddling rod as it connects to the grate. If it becomes disconnected then re-connect by passing the hook under and up through the grate arm.

Seasonal Maintenance

If the appliance is not used for any length of time e.g. summer months then it is recommended that the appliance is cleaned out thoroughly. Air slides, hinge pins and door catches should be lightly oiled. Regular monitoring of internals will highlight condensation problems or water ingress. If these problems occur then the appliance needs drying and the cause of the problem investigating. It is advisable that after a seasonal shut down the appliance is re-cleaned. Remove baffle plate, brick linings and operation of grate. Check flue for any possible blockages. It is advisable to have the chimney swept at least once or twice a year if the appliance is in constant use. The use of poor quality wood makes flues soot or tar up more frequently.

Trouble Shooting

POOR HEAT OUTPUT

A) Stove too small for a room. Seek advice from a Qualified Heating Engineer as to (KW) output required for room size as a guideline the volume of the room in cubic feet divided by 500 i.e. room 15'x15'x8' would require 3.6kw approx.

B) Chimney and/or flue pipe restricted, room ventilation restricted. On installation these will have been checked but regular maintenance is necessary as conditions can change i.e. soot build up, birds nesting, masonry fall, dust build up or furniture blocking vents.

C) Poor quality fuel. Only burn dry seasoned timber, soft woods have a lower heat output than hard woods per hour. Solid fuels vary in heat value check with your coal merchant as to suitability.

DIRTY GLASS PANEL

A) Generally caused by poor fuel quality, see (1c)

B) Fire burning too low, open air vents on stove create hot fire this may 'burn' glass clean.

C) If glass requires cleaning use glass cleaner recommended by your supplier, only use glass cleaner or cold glass. DO NOT USE any abrasives or scrapers as these will scratch glass causing tar build up harder to remove.

UNBURNT FUEL IN FIREBOX

Insufficient air reaching fuel. Open primary air slide, this will supply combustion air to burn fuel fully (unless it has reached a 'point of return'). Check ash pan is full, empty if required, grate may be blocked de-ash with riddler. Check for jammed clinker or nails in grate when fires out and cold.

SMOKE AND FUMES ENTERING ROOM

These are very dangerous and must NOT be tolerated. Open window and allow fire to burn out, seek expert advice immediately. DO NOT USE stove until the problem is solved.

CHIMNEY FIRE

Identified by loud roaring sounds, dense smoke and sparks emitting from chimney. Shut down the air supply by closing the air vents, close the stove door fully and call the fire brigade immediately. Regular chimney maintenance will prevent chimney fires. Seek advice from a qualified chimney sweep

Installation Diagrams

Typical Top Flue Installation using steel closure plate incorporating clean out door for chimney sweeping.

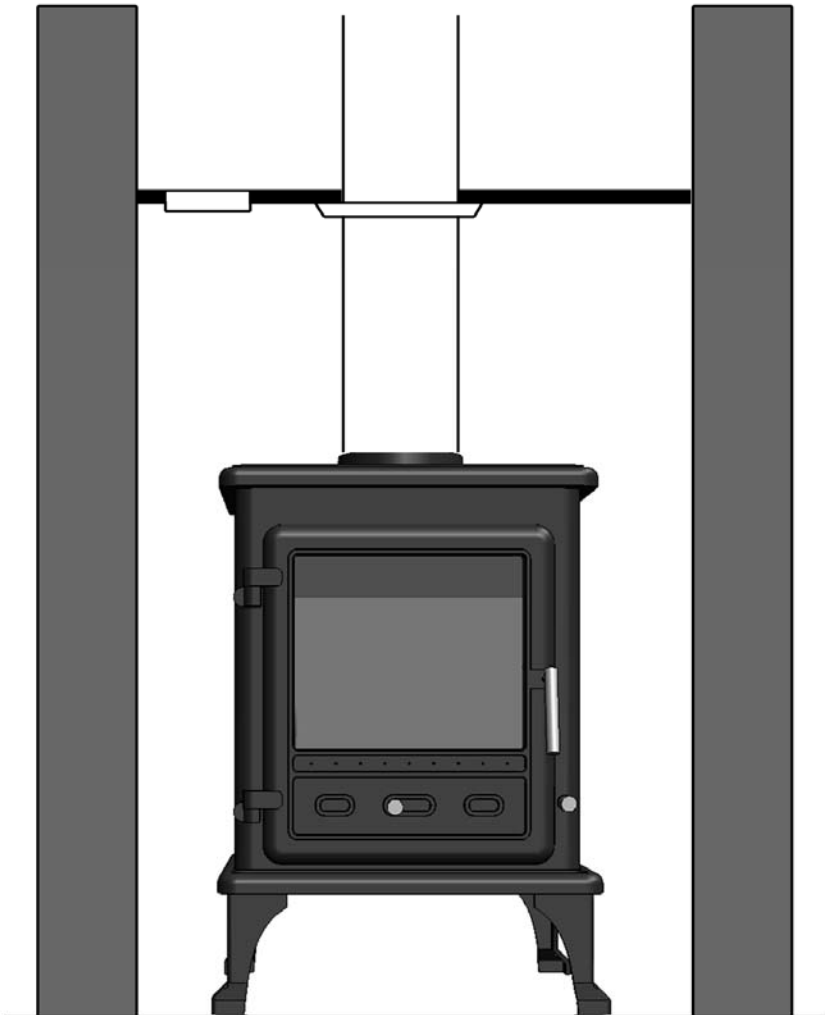

Installation Diagrams

Typical Installation For Inglenook Fireplaces

Inglenook fireplaces can have very large bore chimneys. Check with your installer – you may need stainless steel flexible liner for solid fuel fitting.

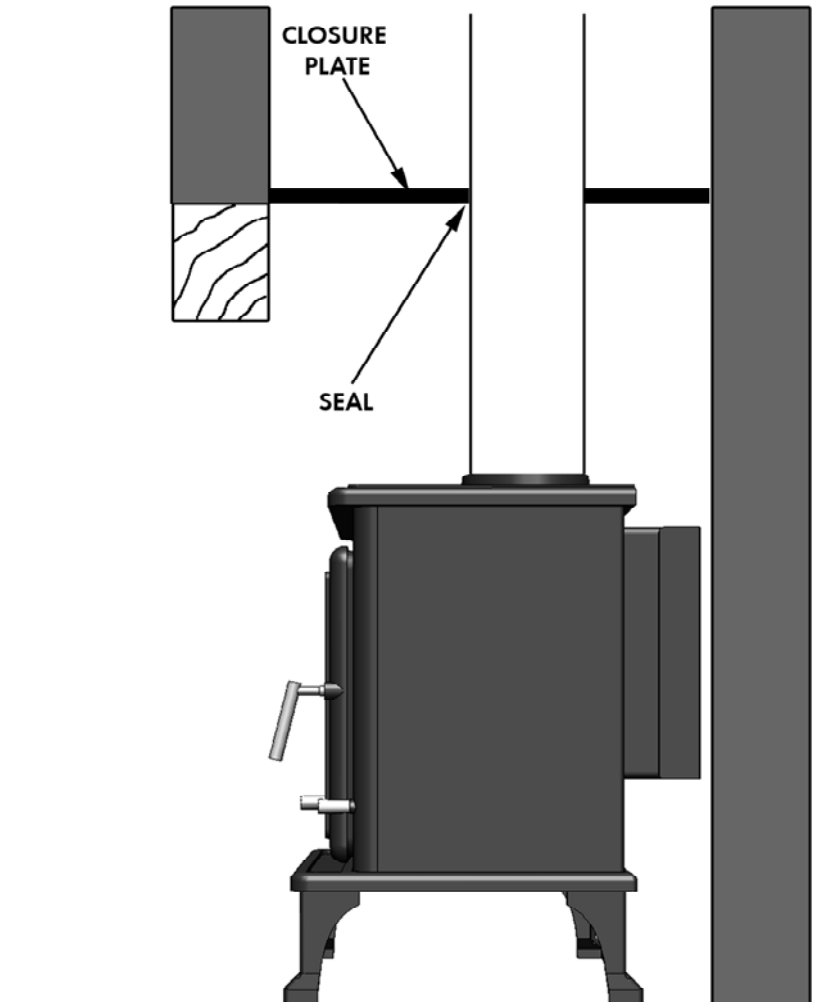

Installation Diagrams

Typical Installation Into In Filled Masonry Fireplaces

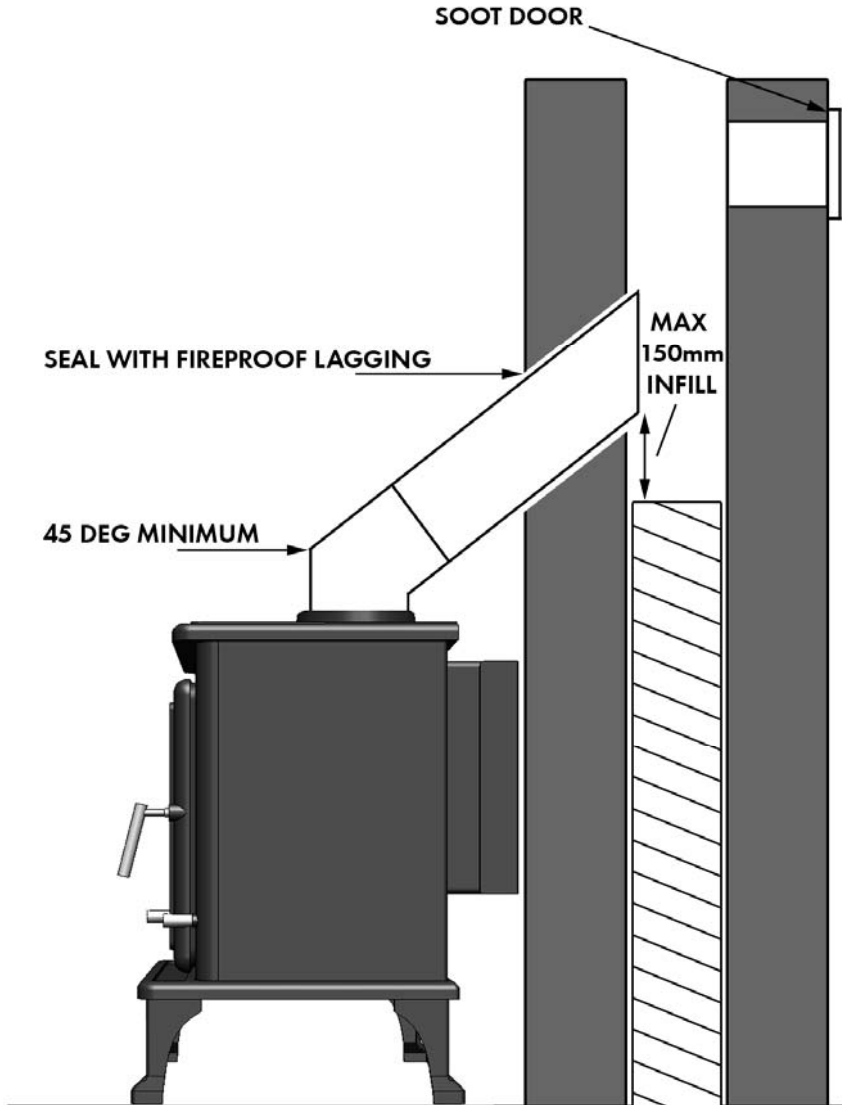

Specifications

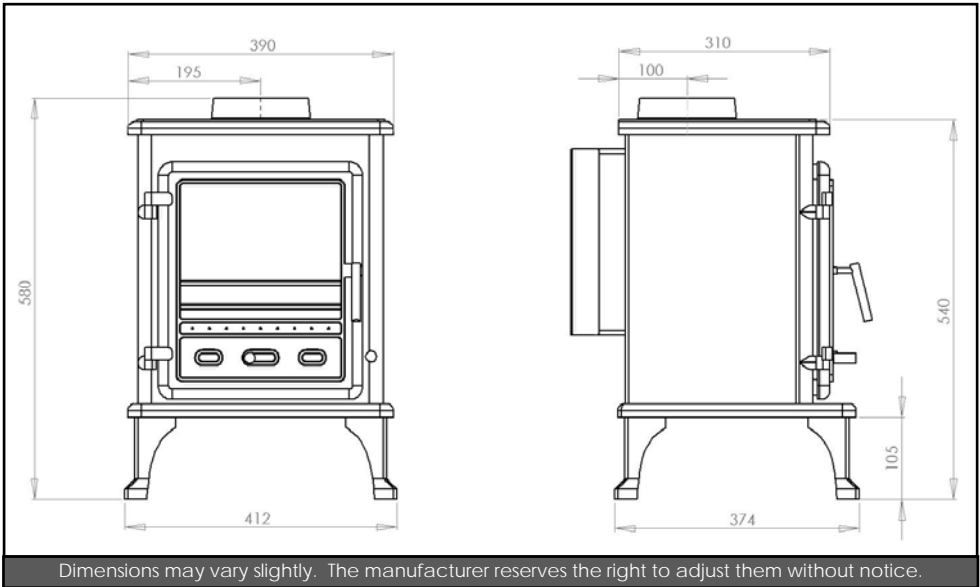

Dimensions may vary slightly. The manufacturer reserves the right to adjust them without notice.

Technical Information			
Nominal Heat Output		kW	4.9
Efficiency		%	72
Flue Gas Temp		°C	313
Refuel Period		Hour	1
Safe Distance to Combustibles	Sides	mm	450
	Rear	mm	400
Flue Outlet Size		mm	125
Flue Gas Mass Flow		g/s	5.1
CO emission at 13% O ₂		%	0.36
Appliance Weight		kg	75

Percy Doughty & Co
 Imperial Point, Express Trading Estate
 Stonehill Rd, Farnworth, Bolton, BL4 9TN